

SEOUL NATIONAL UNIVERSITY
SCHOOL OF MECHANICAL AND AEROSPACE ENGINEERING

SYSTEM ANALYSIS

Spring 2014

HW#3

Assigned : March 19 (We)

Due: March 26 (We)

1. A radar tracks the flight of a projectile (see Figure 1). At time t , the radar measures the horizontal component $v_x(t)$ and the vertical component $v_y(t)$ of the projectile's velocity and its range $R(t)$ and elevation $\pi(t)$. Are these measurements sufficient to compute the horizontal distance D from the radar to the launch point of the projectile? If so, derive the expression for D as a function of g and the measured values $v_x(t)$, $v_y(t)$, $R(t)$, and $\pi(t)$.

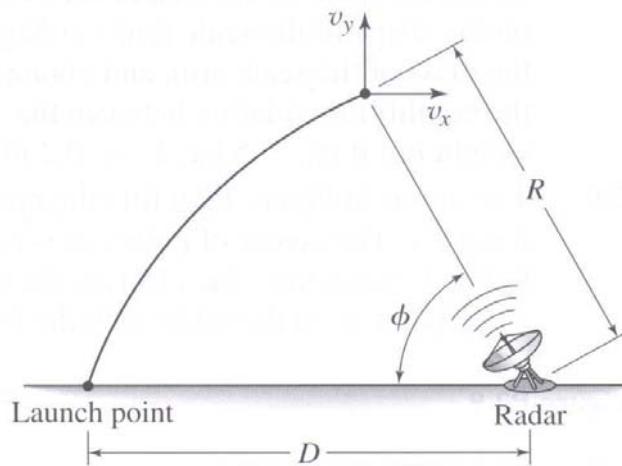

Figure 1

2. The motor in Figure 2 lifts the mass m_L by winding up the cable with a force F_A . The center of pulley B is fixed. The pulley inertias are I_B and I_C . Pulley C has mass m_c . Derive the equation of motion in terms of the speed v_A of point A on the cable with the force F_A as input.

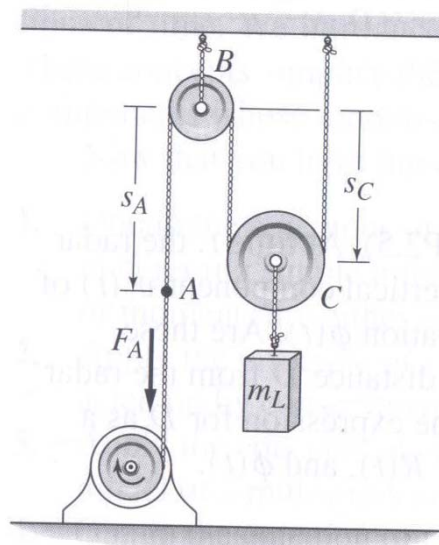

Figure 2

3. The geared system shown in Figure 3 represents an elevator system. The motor has an inertia I_1 and supplies a torque T_1 . Neglect the inertias of the gears, and assume that the cable does not slip on the pulley. Derive an expression for the equivalent inertia I_e felt on the input shaft (shaft 1). Then derive the dynamic model of the system in terms of the speed ω_1 and the applied torque T_1 . The pulley radius is R .

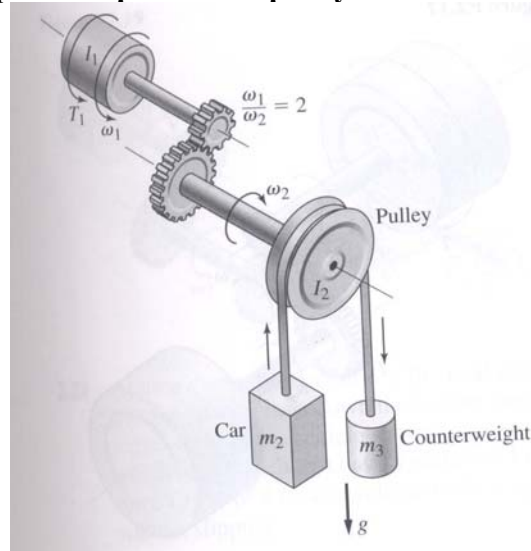

Figure 3

4. The *lead screw* (also called a *power screw* or a *jack screw*) is used to convert the rotation of a motor shaft into a translational motion of mass m (see Figure 4). For one revolution of the screw, the mass translates a distance L (called the *screw lead*). As felt on the motor shaft, the translating mass appears as an equivalent inertia. Use kinematic energy equivalence to derive an expression for the equivalent inertia. Let I_s be the inertia of the screw.

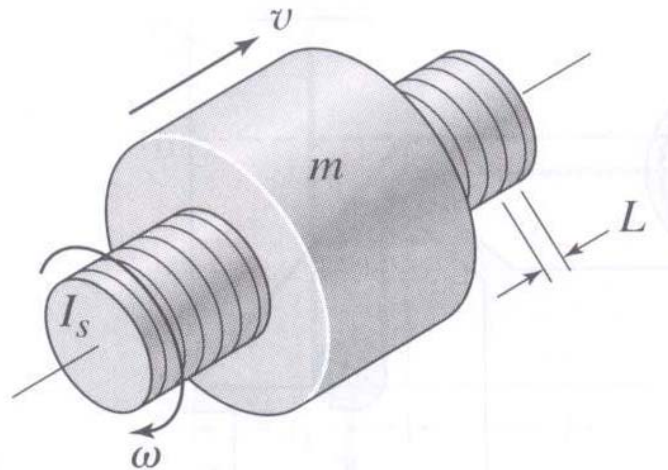

Figure 4

5. At time $t = 0$, the operator of the road roller disengages the transmission so that the vehicle rolls down the incline (see Figure 5). Derive a dynamic model for the vehicle's speed. The two rear wheels weigh 250 kg each and have a radius of 1 m. The front wheel weighs 400 kg and has a radius of 0.5 m. The vehicle body weights 4500 kg. Assume the wheels roll without slipping.

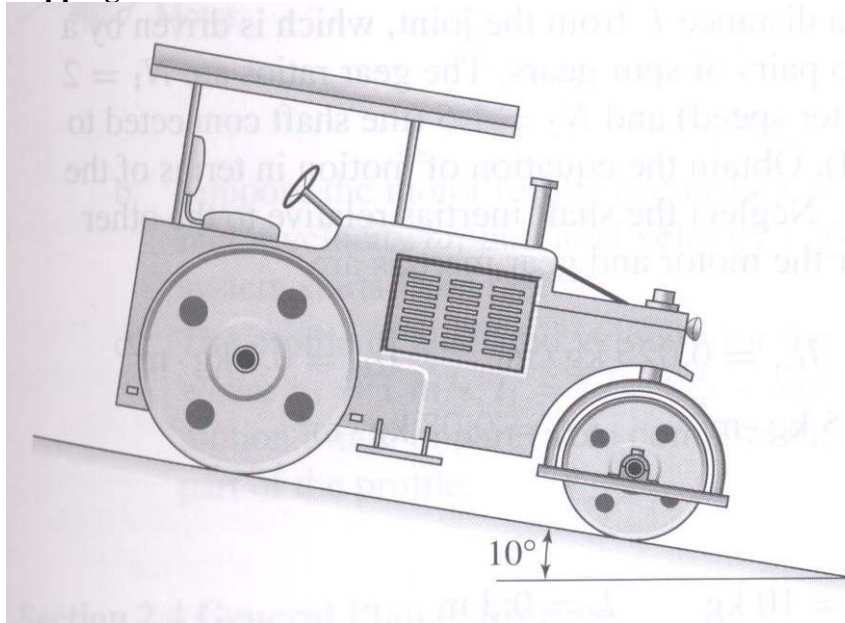

Figure 5

6. A conveyor drive system to produce translation of the load is shown in Figure 6-(a). The redactor is a gear pair that reduces the motor speed by a factor of 10:1. The motor inertia is $I_1 = 0.002 \text{ kg}\cdot\text{m}^2$. The redactor inertia as felt on the motor shaft is $I_2 = 0.003 \text{ kg}\cdot\text{m}^2$. Neglect the inertia of the tachometer, which is used to measure the speed for control purposes. The properties of the remaining elements are given here.

Sprockets:

Sprocket 1: radius = 0.05 m weight = 9 N

Sprocket 2: radius = 0.15 m weight = 89 N

Chain weight: 107 N

Drive shaft: radius = 0.04m weight = 22N

Drive wheels (four of them): radius = 0.2 m weight = 89 N

Drive chains (two of them): weight = 670 N each

Load friction torque measured at the drive shaft: 54 N·m

Load weight: 450 N

- Derive the equation of motion of the conveyor in terms of the motor velocity ω_1 , with the motor torque T_1 as input.
- Suppose the motor torque is constant at 10N·m. Determine the resulting motor velocity ω_1 and load velocity v as functions of time, assuming the system starts from rest.
- The profile of a desired velocity for the load is shown in Figure 6-(b), where $v_0 = 1 \text{ m/s}$, $t_1 = t_3 = 0.5 \text{ s}$, and $t_2 = 2 \text{ s}$. Use the equation of motion found in part (a) to compute the required motor torque for each part of the profile.

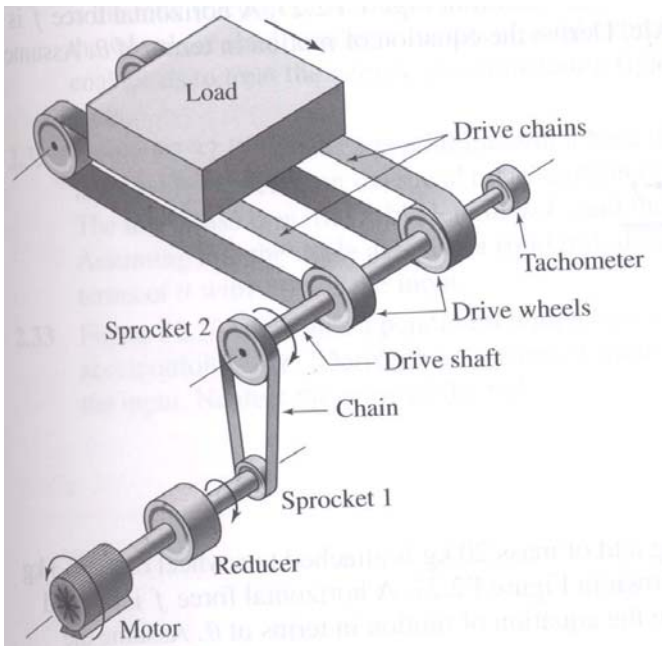

Figure 6-(a)

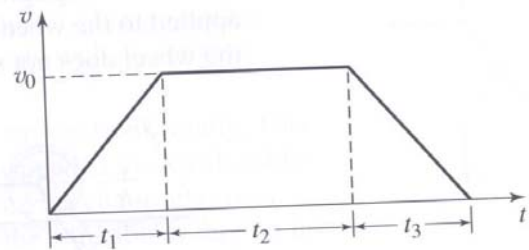

Figure 6-(b)

7. The vehicle operates with shaft torque T_s and brake torque T_b . Derive a dynamic model for vehicle. (Use some assumptions and coefficients if it needed)

Input: $u_1 = T_s, u_2 = T_b$,

$x = \text{distance}$

State:

$\dot{x} = \text{velocity}$

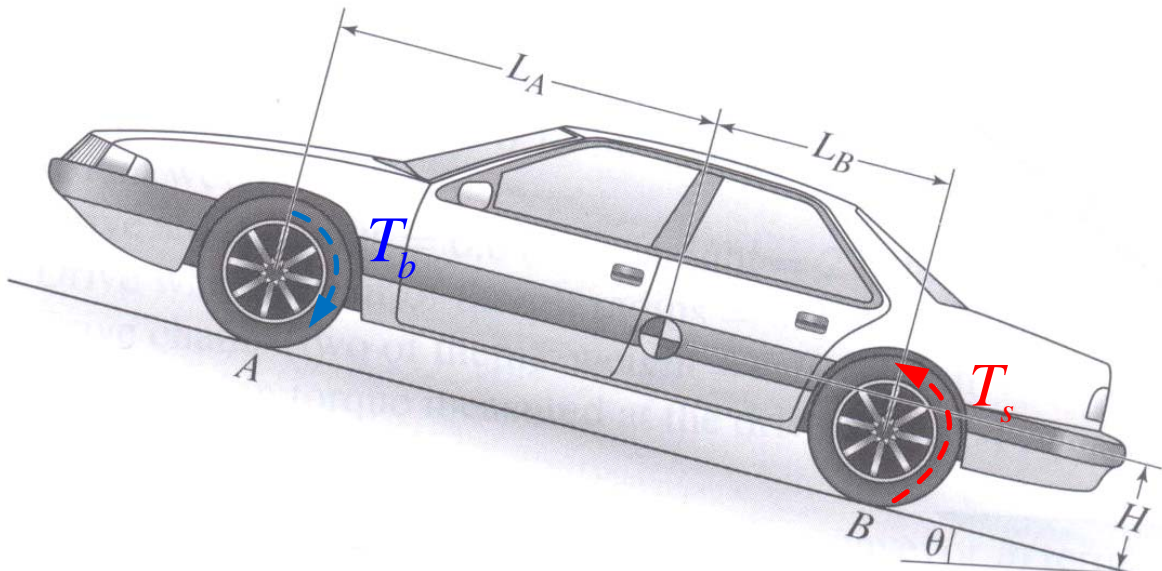

Figure 7