

해양플랜트 공학 입문

서유택

Introduction

Summary of last class

- Subsea field development
- Wet tree vs. Dry tree
- Fixed / Floating – FPSO
- Subsea production system and its operation
- Multicomponent phase diagram
- Black oil / Volatile oil / Gas condensate / Wet gas / Dry gas

Here,

We will have a look subsea tree, manifolds, and pipelines.

Field Development Plan

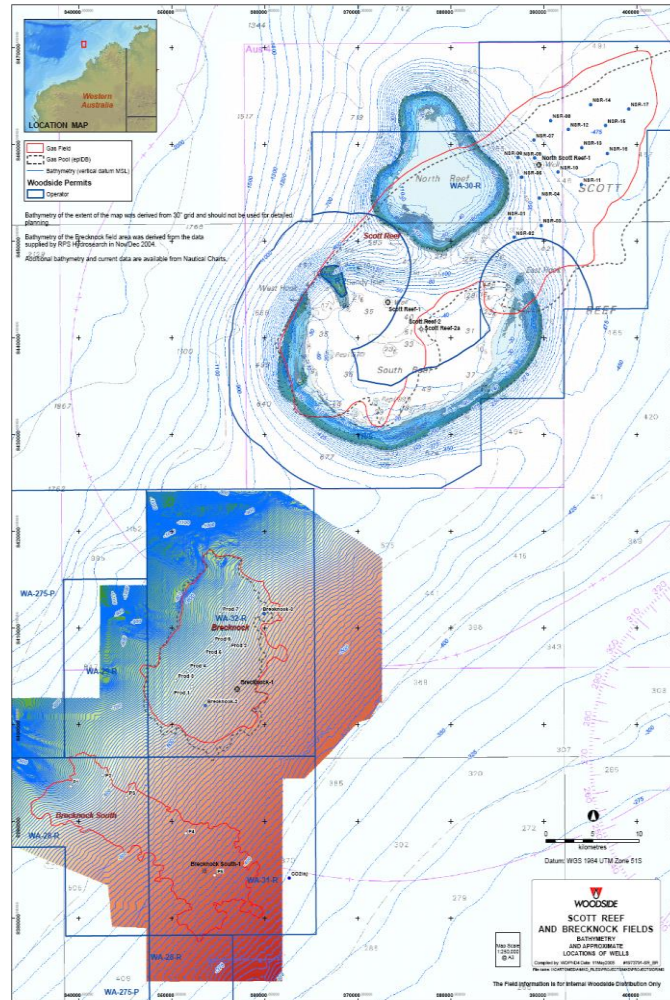

A Tiny Rock Sitting
On A Remote Reef
Is Now The Most
Valuable Piece Of
Real Estate In
Australia
(Business insider,
16 May 2014)



Upstream concept selection

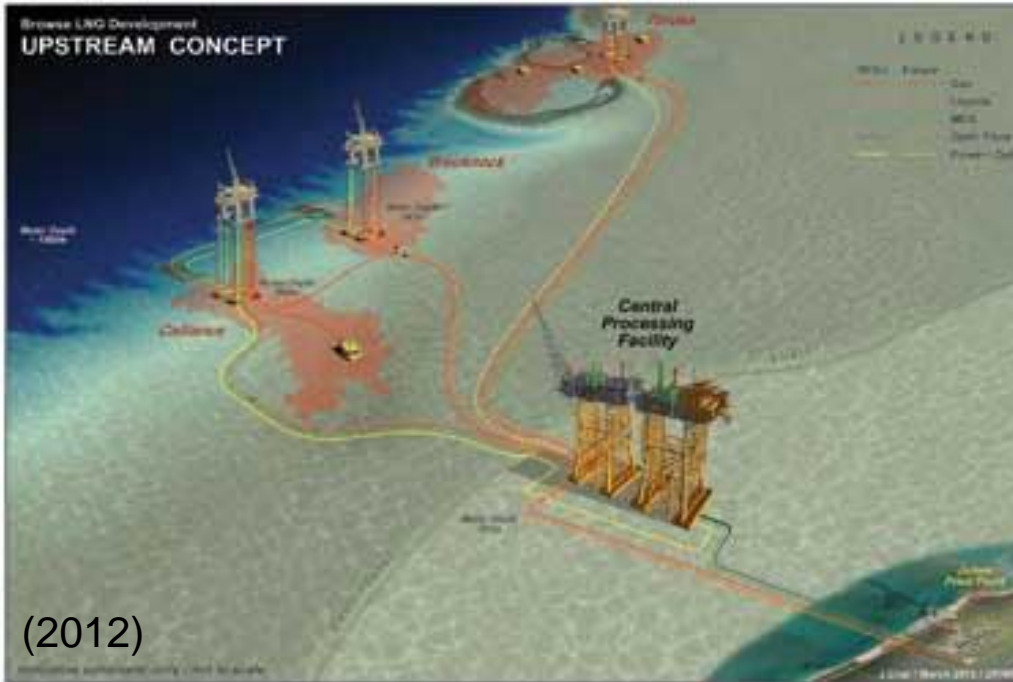

(2012)



Image courtesy of Shell

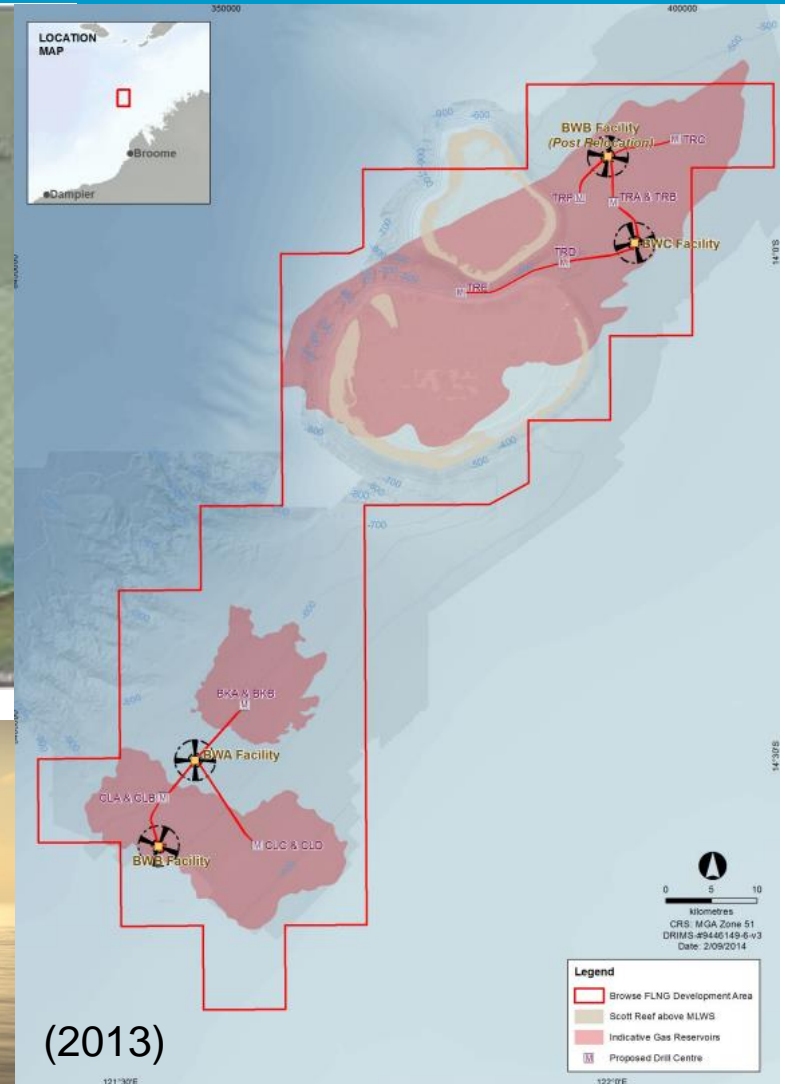

(2013)

Well layout

- Field development planners need to work closely with the reservoir and drilling engineers early in the planning stages to establish a good well location plan.
- Once the reservoir is mapped and reservoir models created, the number of wells, types of wells, and their locations can be optimized.
- Well layout is usually an exercise of balancing the need to space the wells out for good recovery of the reservoir fluids against the cost savings of grouping the wells in clusters.
- Add to this the consideration of using extended reach wells, and the number of possible variables to consider becomes great.
- A further consideration, reservoir conditions permitting, is the use of fewer, high production rate wells through horizontal well completions or other well technology. Here again, there are cost trade-off considerations.

Satellite well system

- A satellite well is an individual subsea well. Figure 2-20 illustrates a typical satellite tie-back system.

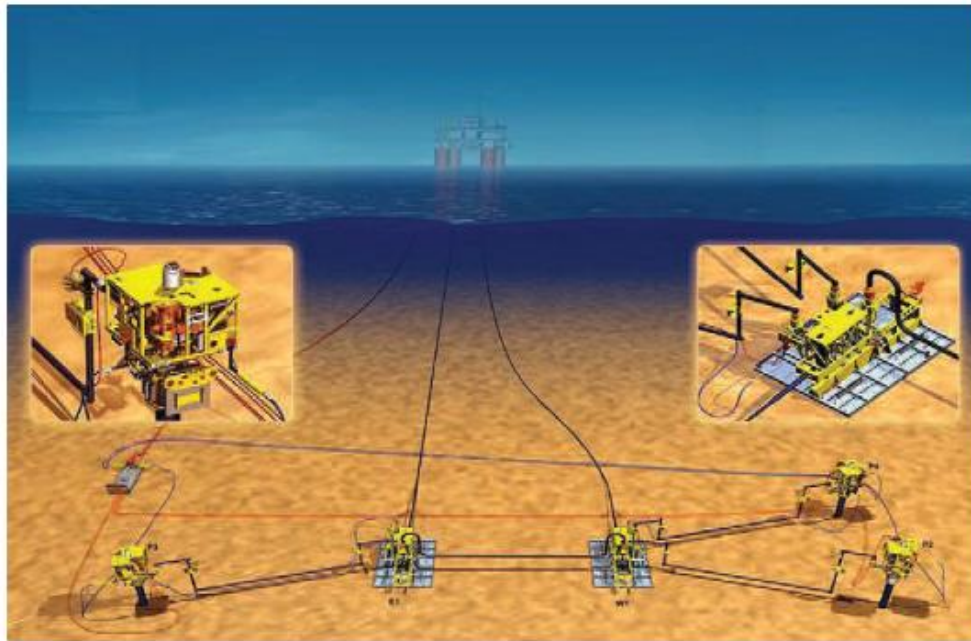

Figure 2-20 Typical Satellite Tie-Back System [2]

: The wells are widely separated and the production is delivered by a single flowline from each well to a centrally located subsea manifold or production platform.

Clustered well system

- If subsea wells can be grouped closely together, the development cost will usually be less than that for an equivalent number of widely dispersed wells.
- Well groupings may consist of satellite wells grouped in a cluster, or a well template, in which the well spacing is closely controlled by the template structure.

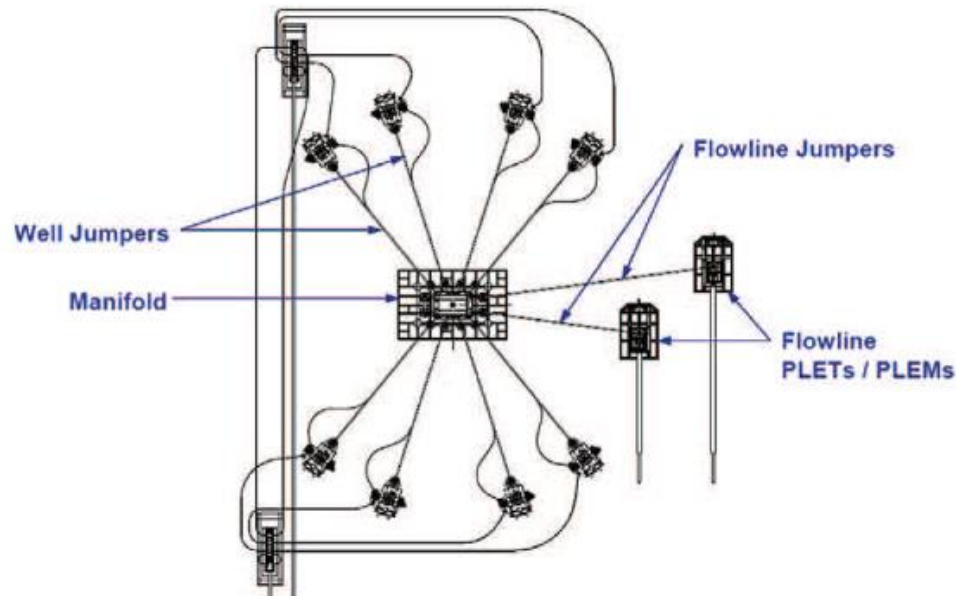
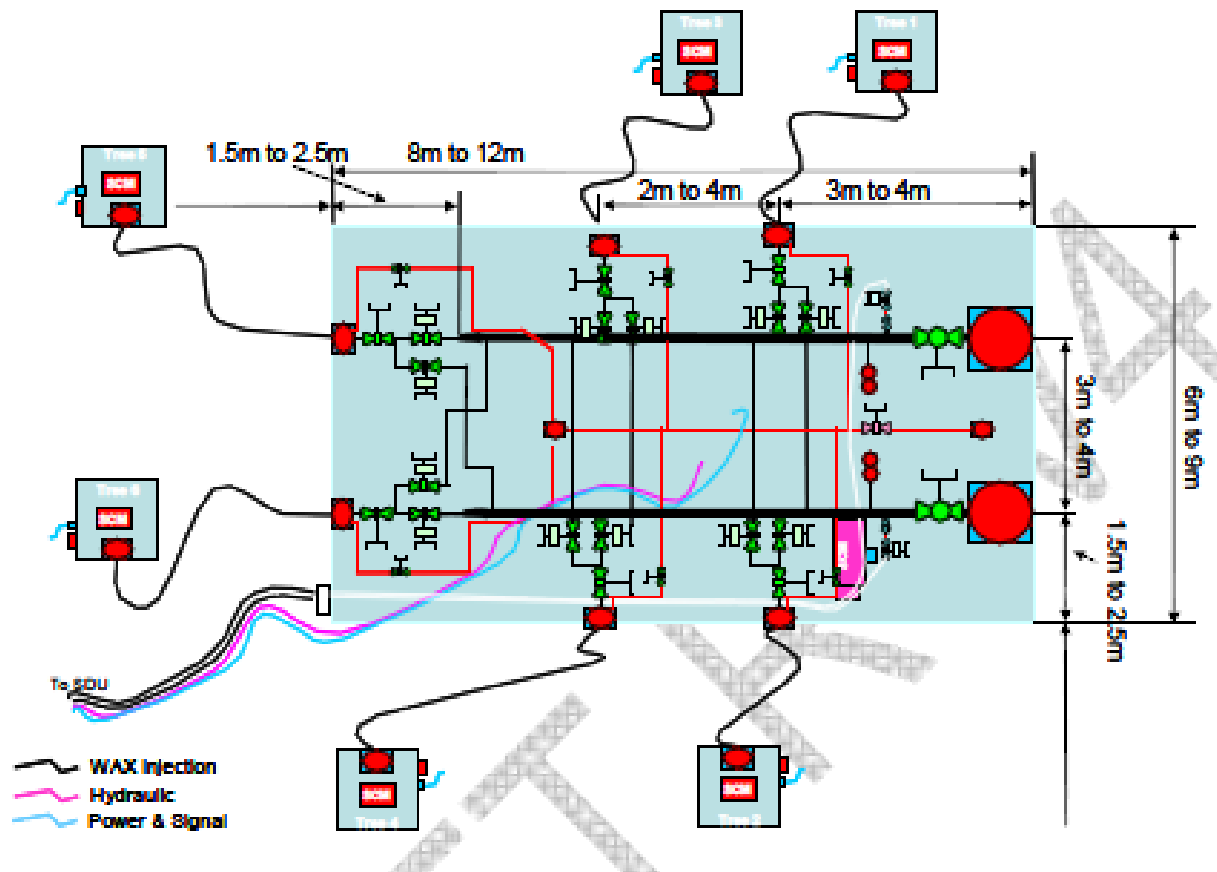

Figure 2-21 Typical Manifold Cluster Layout [2]

- Detailed design of manifold



Subsea tree

- Function requirement
 - : Direct the produced fluid from the well to the flowline (called production tree) or to canalize the injection of water or gas into the formation (called injection tree).
 - : Regulate the fluid flow through a choke (not always mandatory).
 - : Monitor well parameters at the level of the tree, such as well pressure, annulus pressure, temperature, sand detection, etc.
 - : Safely stop the flow of fluid produced or injected by means of valves actuated by a control system.
 - : Inject into the well or the flowline protection fluids, such as inhibitors for corrosion or hydrate prevention.

Well head

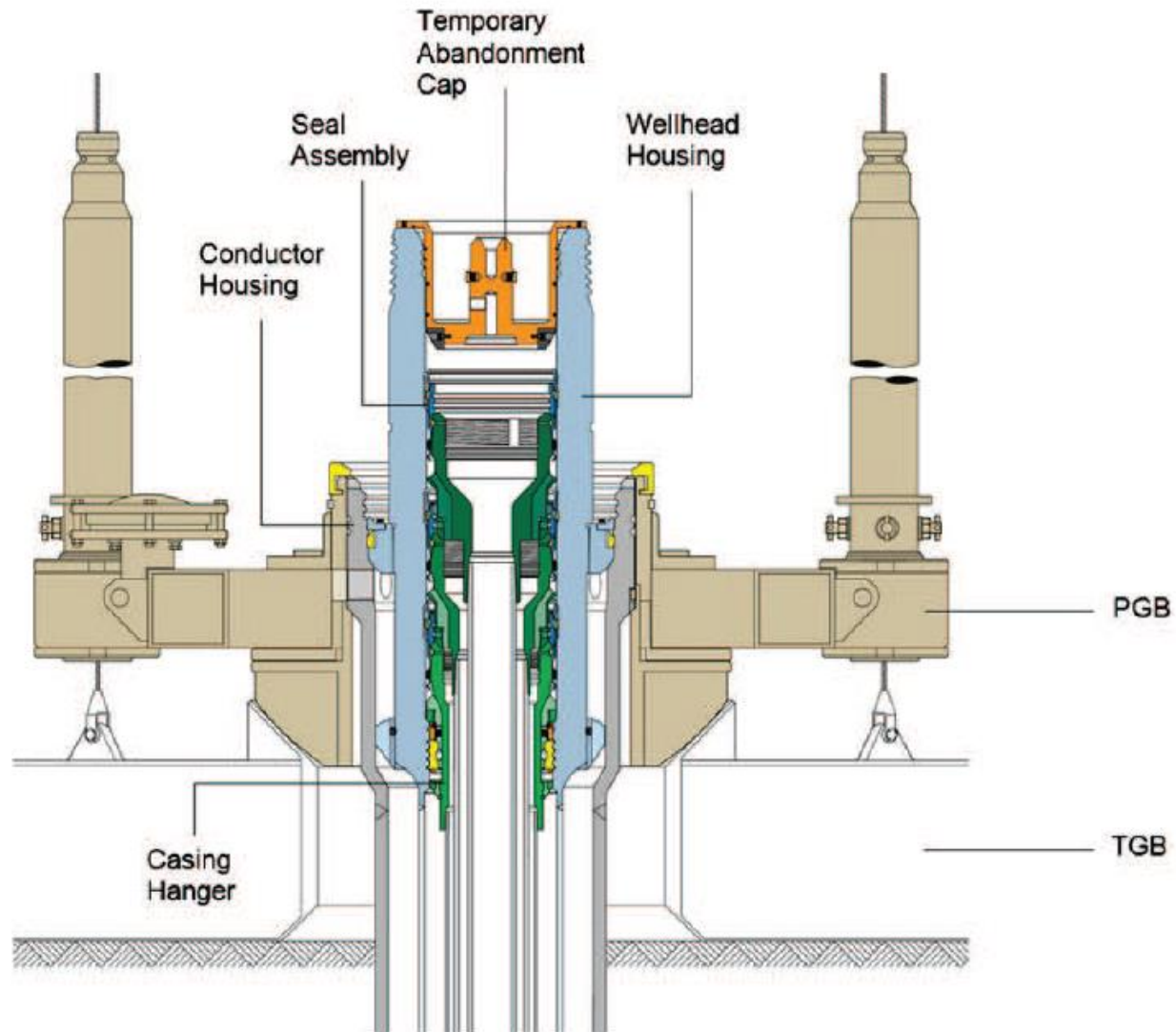
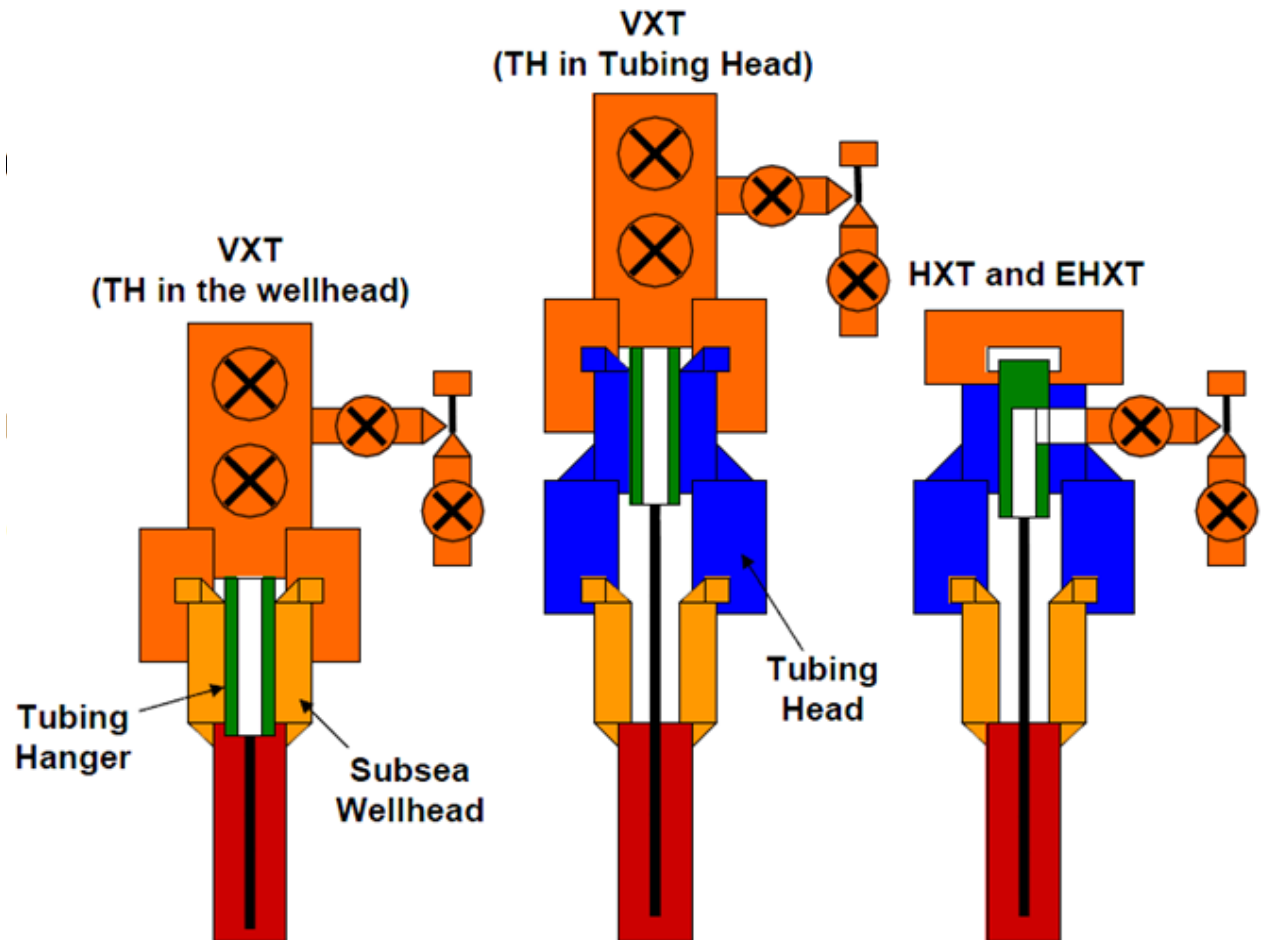

Figure 22-5 Typical 18³/₄-in. Subsea Wellhead System (Courtesy of Drill-Quip)

Subsea trees



Vertical Xmass Tree

- The master valves are configured above the tubing hanger in the vertical Xmas tree (VXT).
- VXTs are applied commonly and widely in subsea fields due to their flexibility of installation and operation.
- The production and annulus bore pass vertically through the tree body of the tree. Master valves and swab valves are also stacked vertically.
- The tubing hanger lands in the wellhead, thus the subsea tree can be recovered without having to recover the downhole completion.

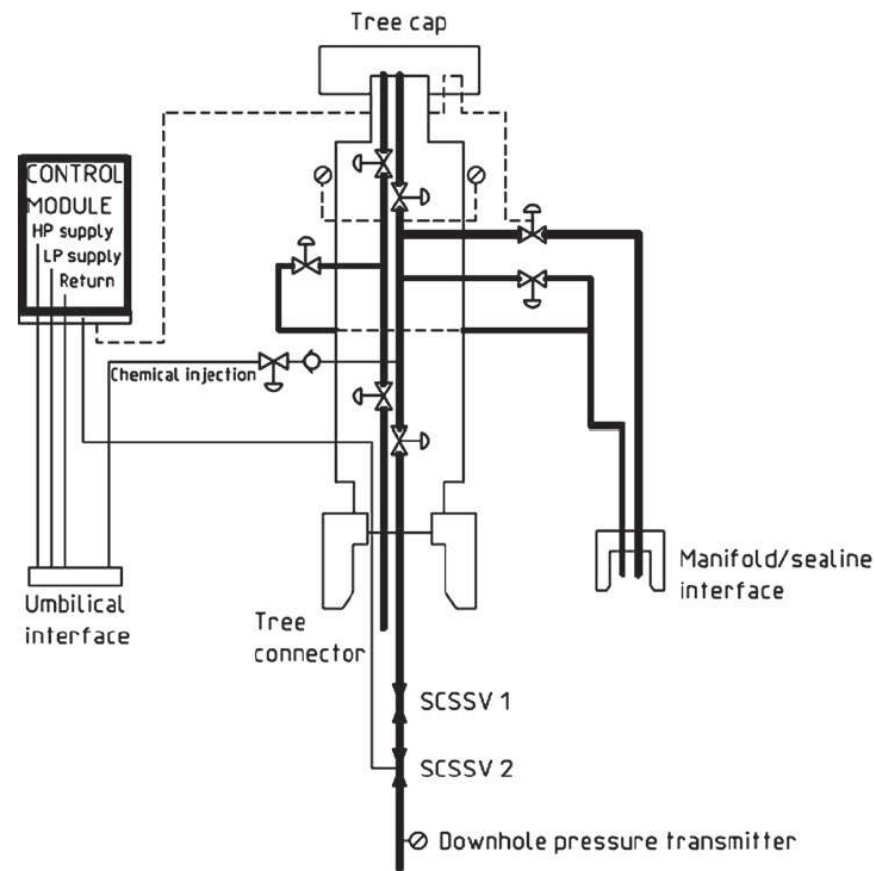

Figure 22-15 Schematic of Vertical Xmas Tree (Courtesy of API RP 17A)

Main components of tree

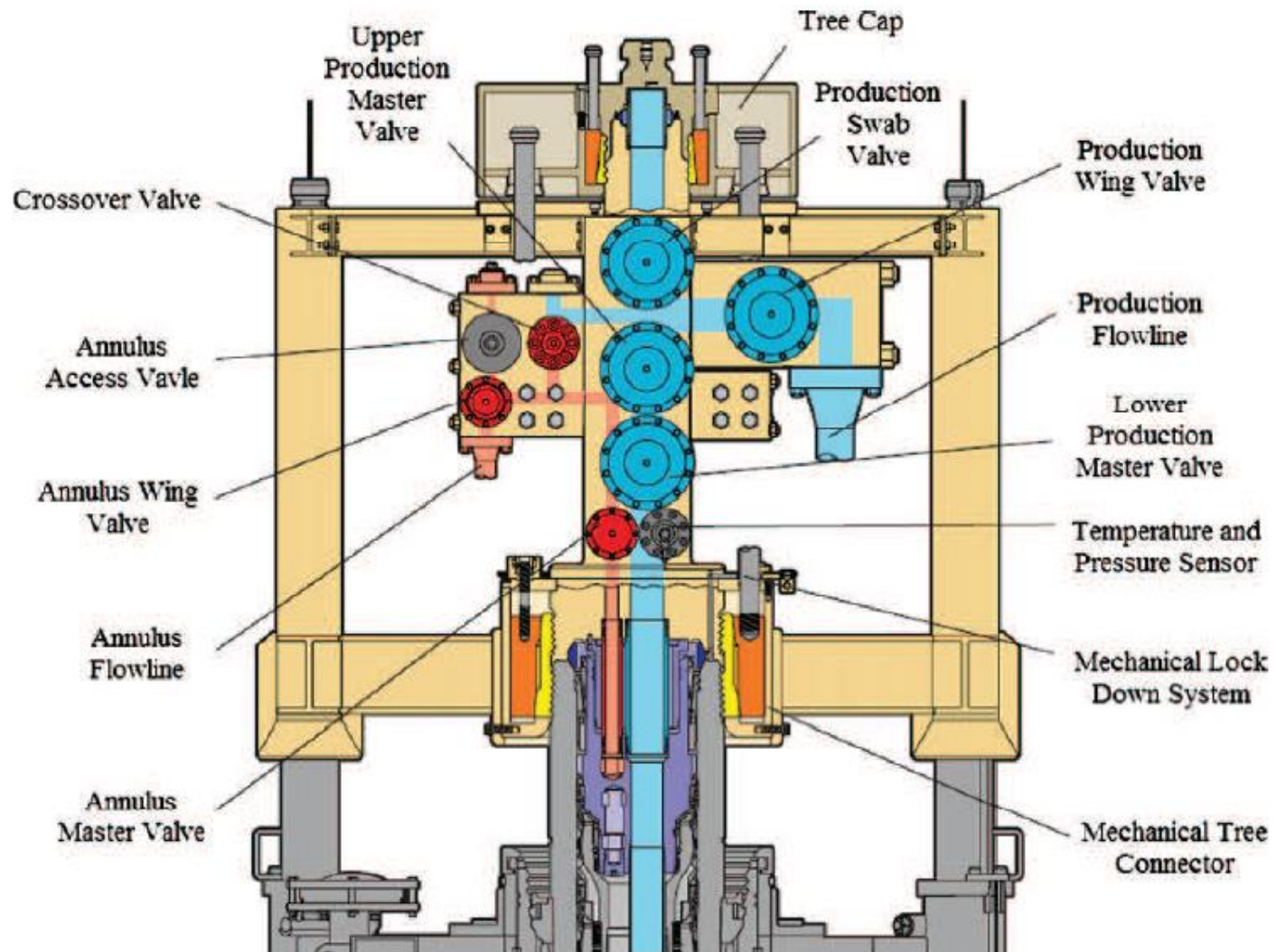
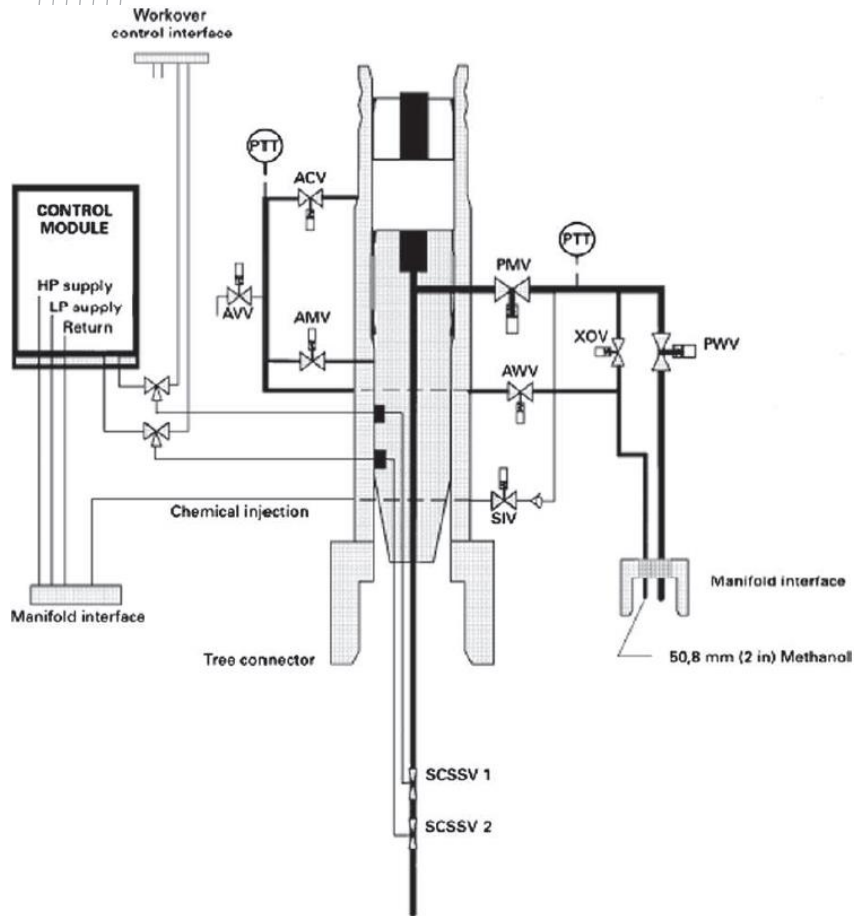

Figure 22-21 Typical Components of a VXT (Courtesy of Dril-Quip)

Horizontal Xmass Tree



- The valves are mounted on the lateral sides, allowing for simple well intervention and tubing recovery.
- This concept is especially beneficial for wells that need a high number of interventions.
- Swab valves are not used in the HXT since they have electrical submersible pumps applications.
- The key feature of the HXT is that the tubing hanger is installed in the tree body instead of the wellhead.
- This arrangement requires the tree to be installed onto the wellhead before completion of the well.

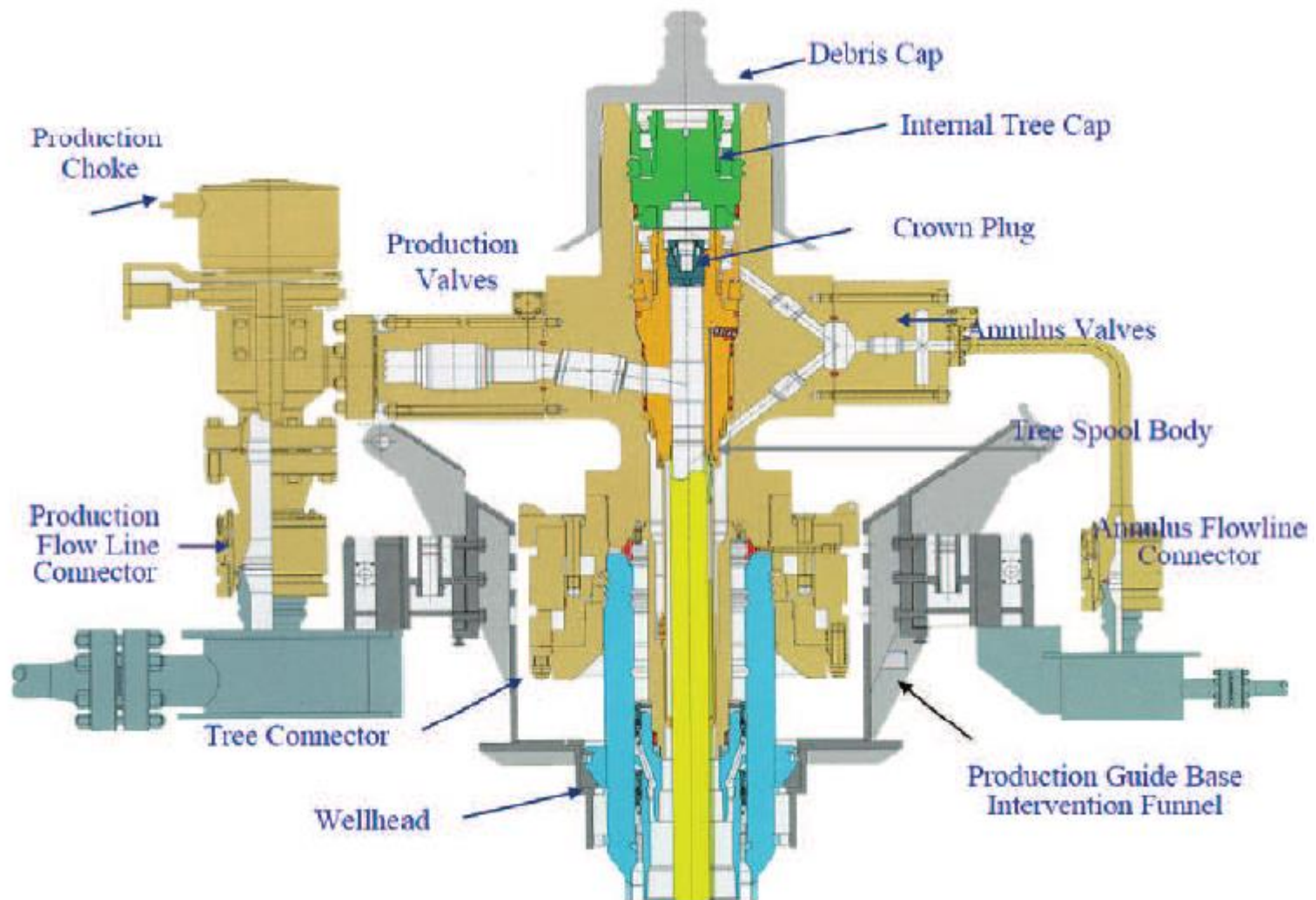

Figure 22-22 Typical Components of an HXT



Figure 22-14 Xmas Vertical Tree (Courtesy of FMC)

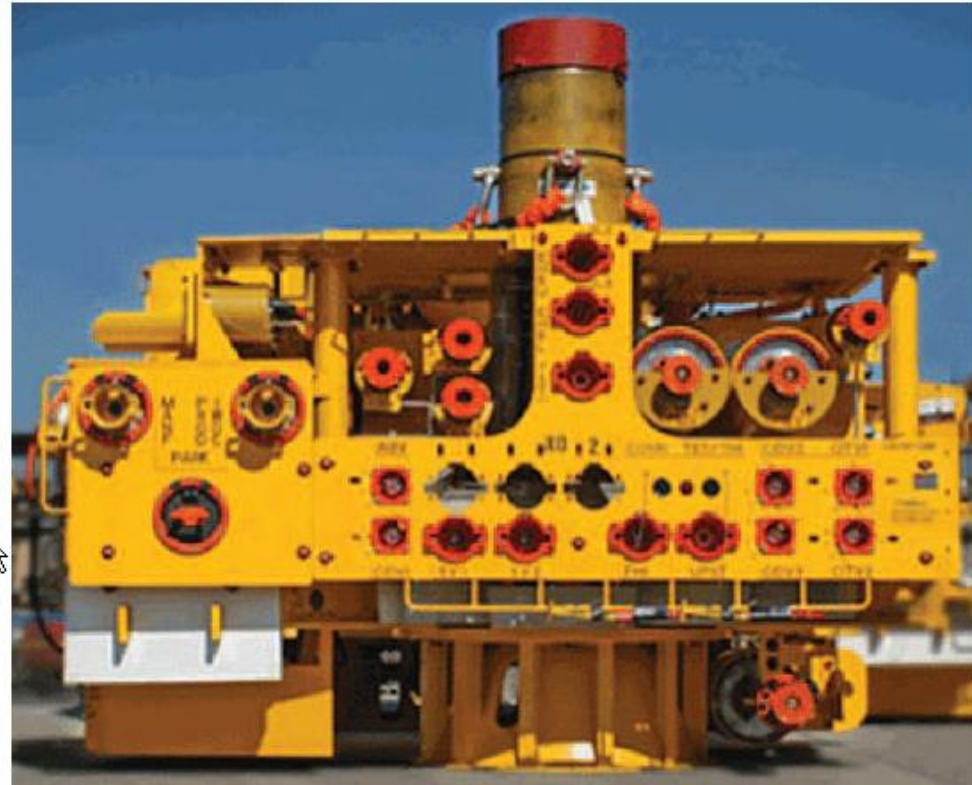

Figure 22-16 Horizontal Xmas Tree (Courtesy of FMC)

Selection criteria

- The cost of an HXT is much higher than that of a VXT; typically the purchase price of an HXT is five to seven times more.
- A VXT is larger and heavier, which should be considered if the installation area of the rig is limited.
- Completion of the well is another factor in selecting an HXT or VXT. If the well is completed but the tree has not yet been prepared, a VXT is needed. Or if an HXT is desired, then the well must be completed after installation of the tree.
- An HXT is applied in complex reservoirs or those needing frequent workovers that require tubing retrieval, whereas a VXT is often chosen for simple reservoirs or when the frequency of tubing retrieval workovers is low.
- An HXT is not recommended for use in a gas field because interventions are rarely needed.

Design process

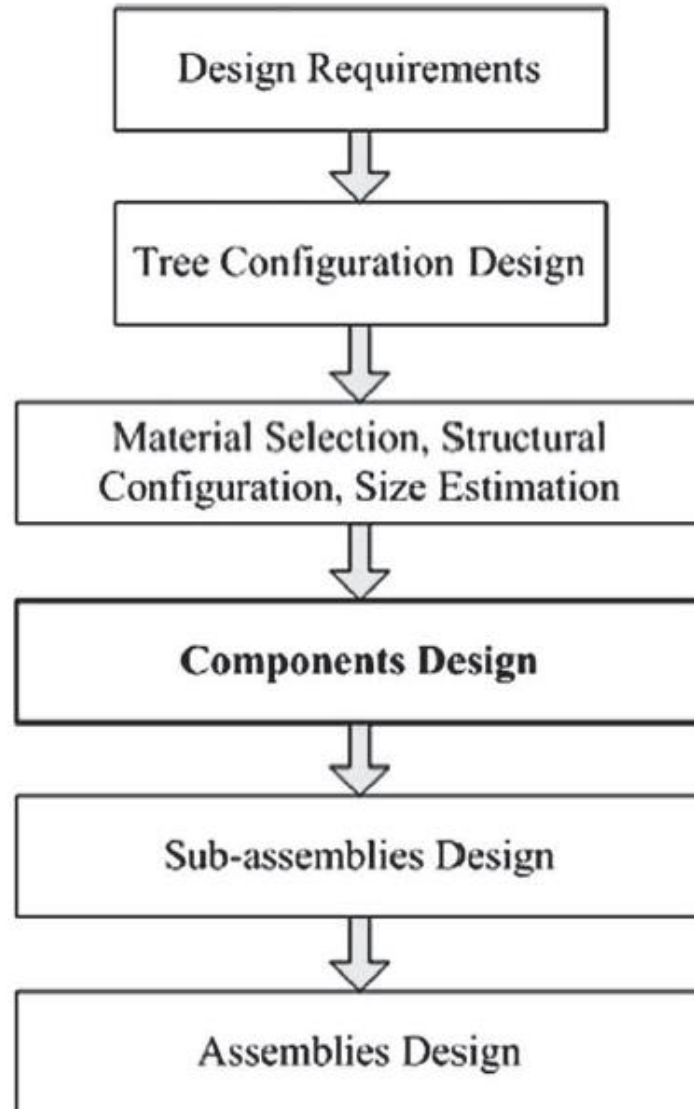

Figure 22-18 Design Process of Subsea Xmas Tree

Flowline connector

- A flowline connector is used to connect subsea flowlines and umbilicals via a jumper to the subsea tree. In some cases, the flowline connector also provides the means for disconnecting and removing the tree without retrieving the subsea flowline or umbilical to the surface.



Figure 22-28 Flowline Connector (Courtesy of FMC)

Tie-in to flowline

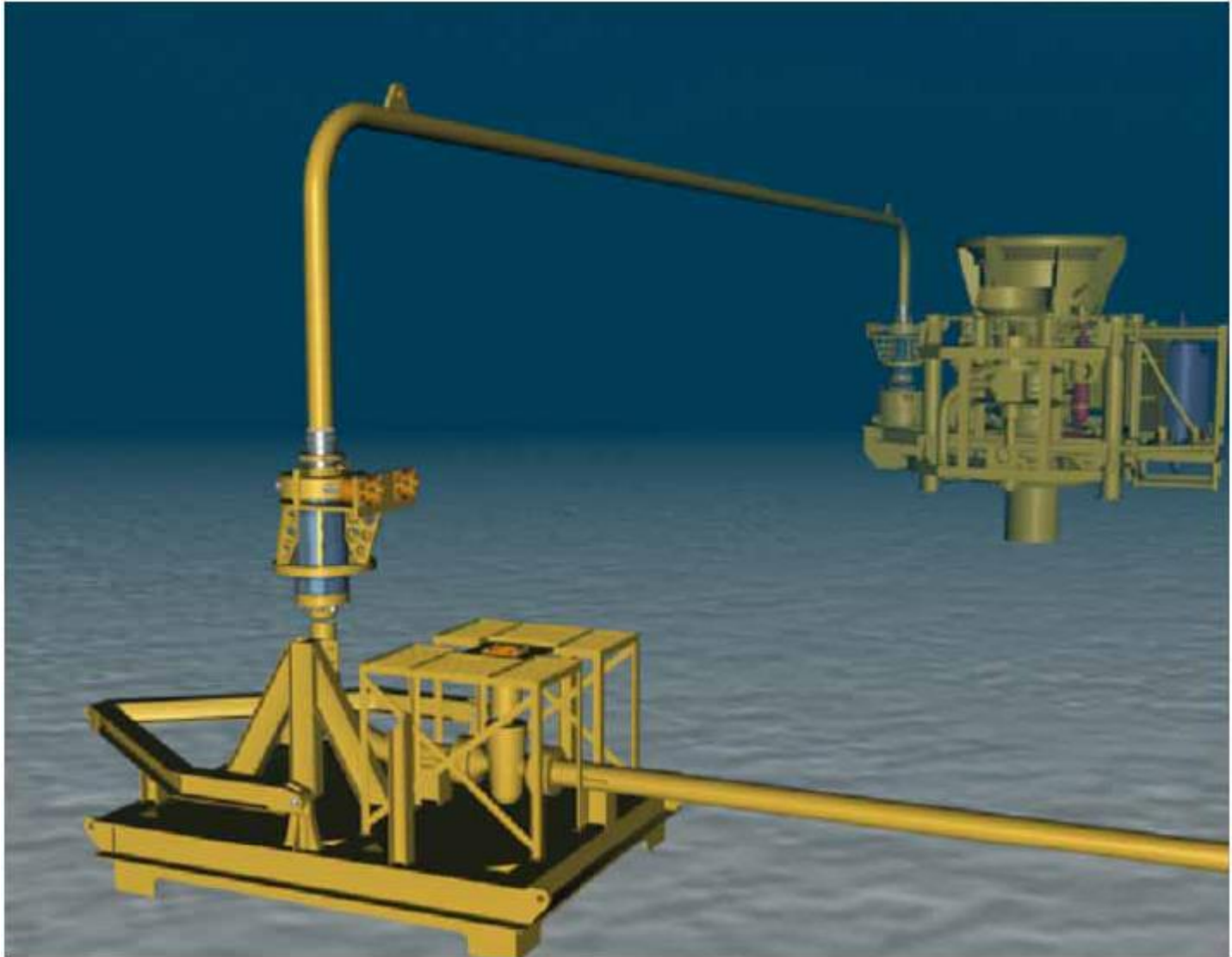

Tree valves

- Subsea Xmas tree contains various valves used for testing, servicing, regulating, or choking the stream of produced oil, gas, and liquids coming up from the well below

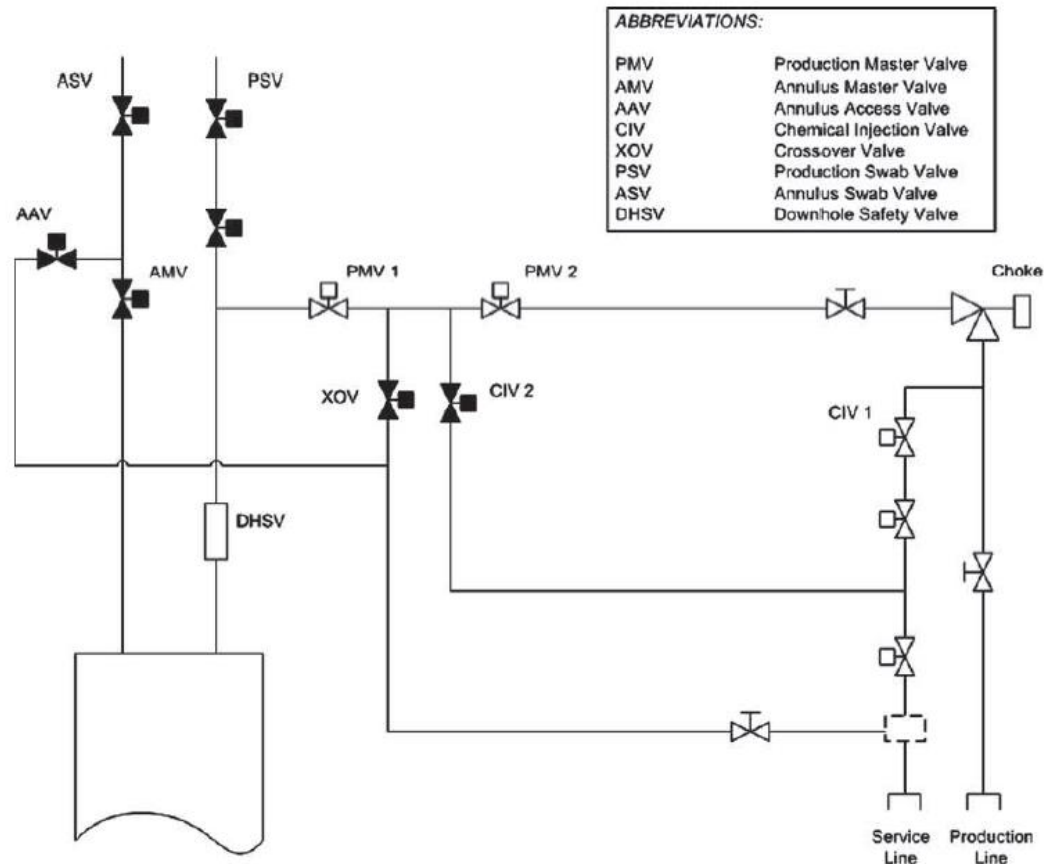

Figure 22-30 Configuration of Tree Valves

Production choke

- A production choke is a flow control device that causes pressure drop or reduces the flow rate through an orifice. It is usually mounted downstream of the PWV in a subsea tree in order to regulate the flow from the well to the manifold.

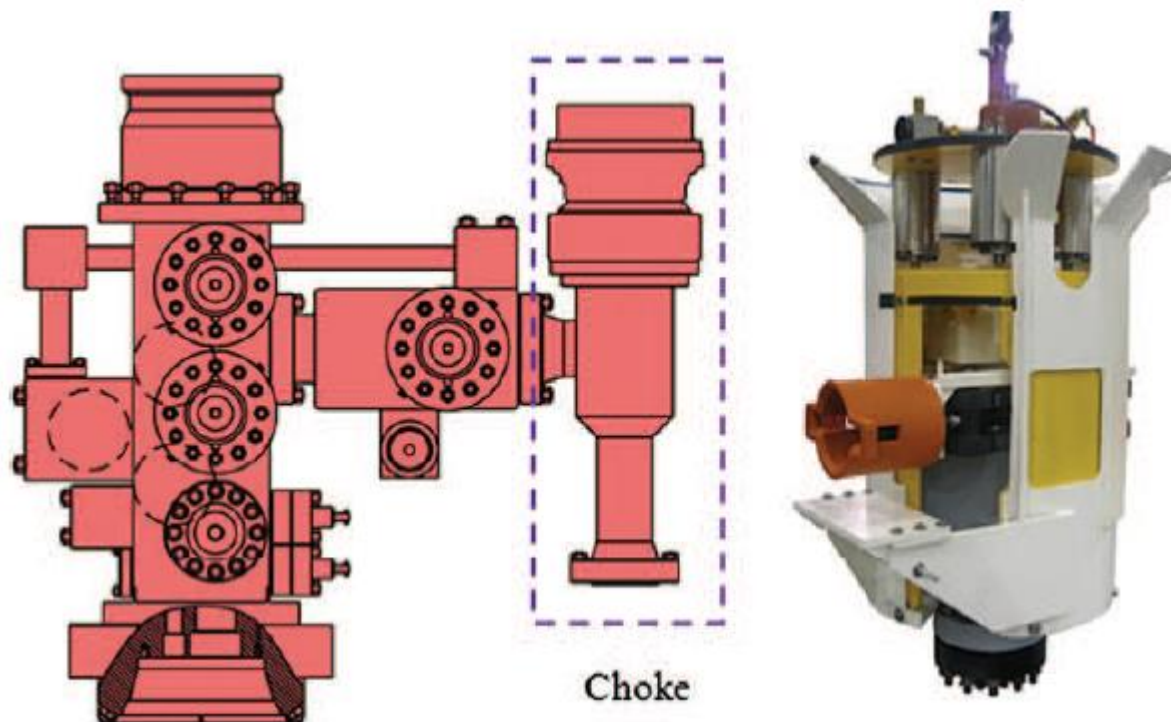

Figure 22-31 Subsea Choke (Courtesy of Cameron and MasterFlo)

- Trims / orifices types

- : Typical orifices used are of the disk type or needle/plug type.
- : The disk type acts by rotating one disk and having one fixed. This will ensure the necessary choking effect.
- : The needle/plug type regulates the flow by moving the insert and thereby providing a gap with the body. The movement is axial.

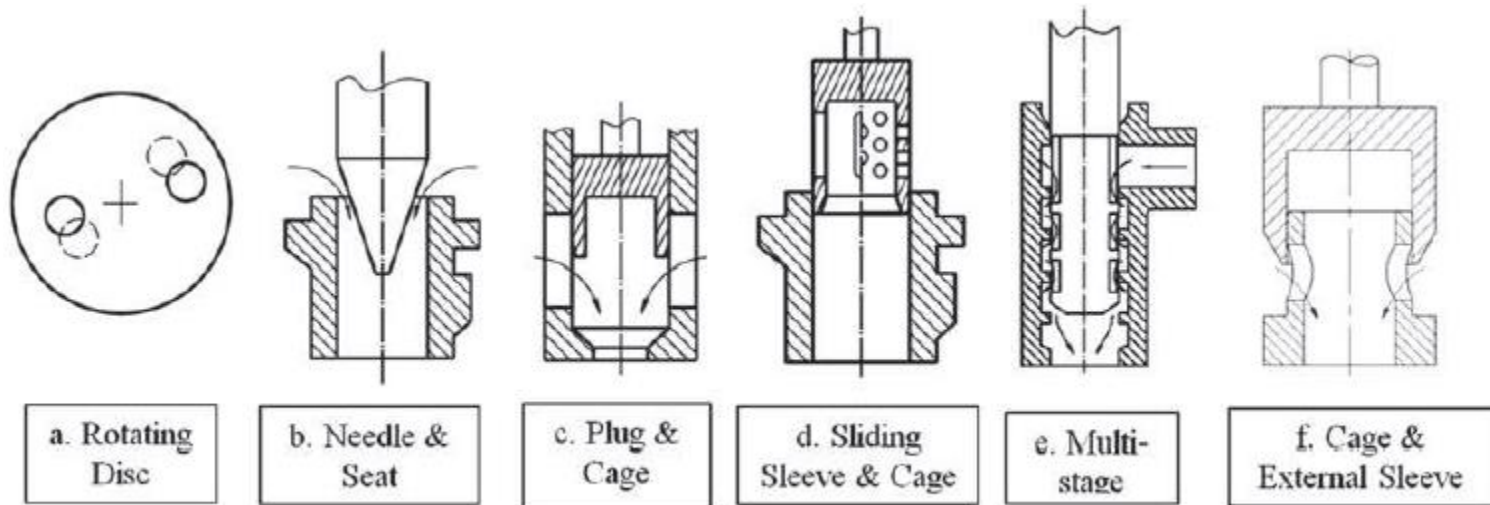

Figure 22-32 Trim Types

- Choke Design Parameters

- : Several measurements must be known in order to select the proper choke for a subsea production system

- : how fast the flow is coming into the choke, the inlet pressure P_1 of the flow, the pressure drop that occurs crossing the orifice, and the outlet or downstream pressure P_2 of the flow,

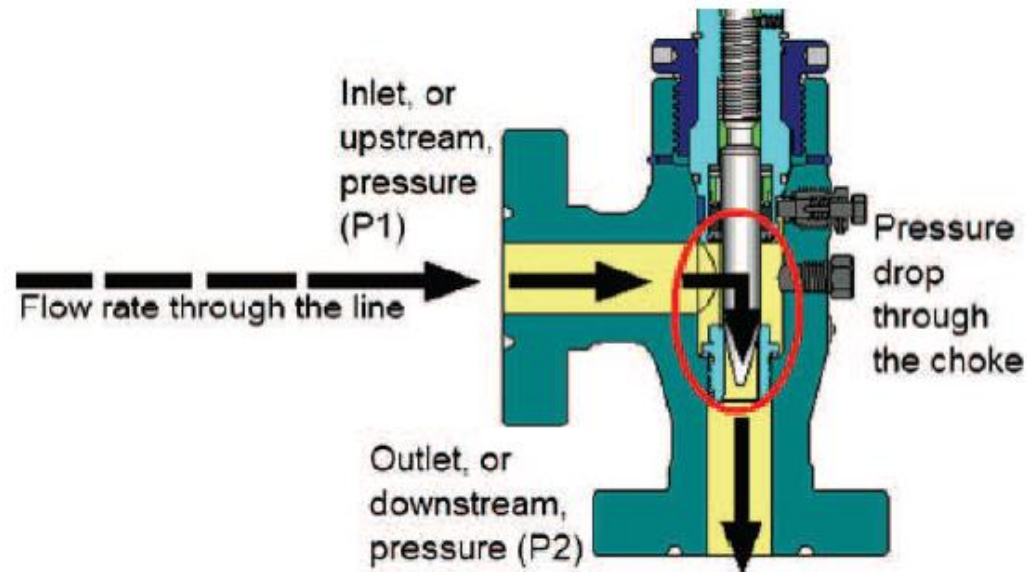

Figure 22-33 Choke Schematic (Courtesy of Cameron)

- Choke sizing is determined by coefficient value (C_v), which takes into account all dimensions as well as other factors, including size and direction changes, that affect fluid flow in a choke.
- The C_v equals number of gallons of per minute that will pass through a restriction (orifice) with a pressure drop of 1 psi at 60°C.
- This C_v calculation normally follows Instrument Society of America (ISA) guidelines.

Pressure drop and recovery

- Pressure is maintained through the tree piping as P_1 . When the flow crosses the orifice of the choke, the pressure drops. But soon the pressure will recover to a level (P_2).

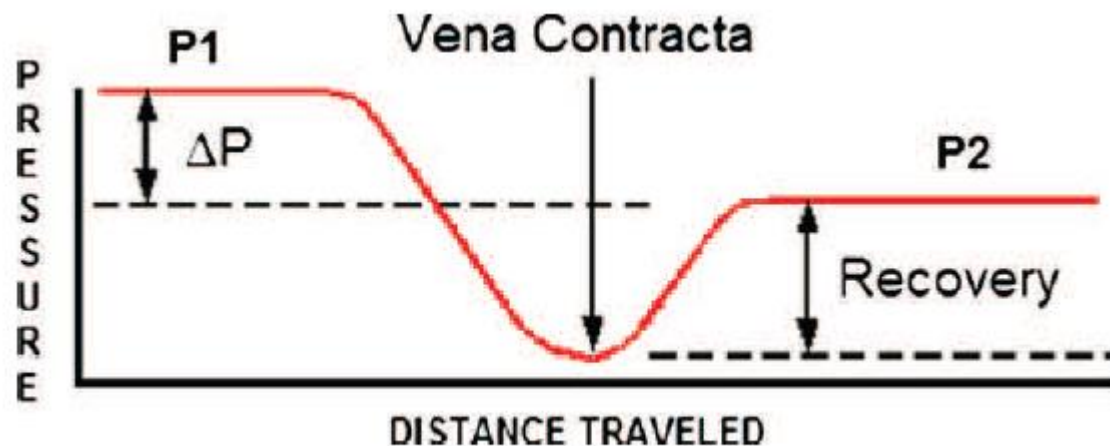

Figure 22-34 Pressure Drop in a Choke (Courtesy of Cameron)

- The pressure drop is determined by the equation $\Delta P = P_1 - P_2$ (*inlet pressure minus outlet pressure*).
- The ΔP ratio, $\Delta PR = \Delta P / P_1$.
- It is considered the most important parameter for evaluating and ensuring the success of the subsea field development project.
- It is used to measure the capacity and recovery of the choke. The higher the value of ΔPR , the higher the potential damage to the choke trim or body. Normally a special review of the trim is required if DPR is beyond 0.6.

Tree cap

- Tree caps are designed to both prevent fluid from leaking from the wellbore into the environment and small dropped objects from getting into the mandrel.
- Tree caps are installed, locked, unlocked, released, and recovered via ROV-assisted operations.

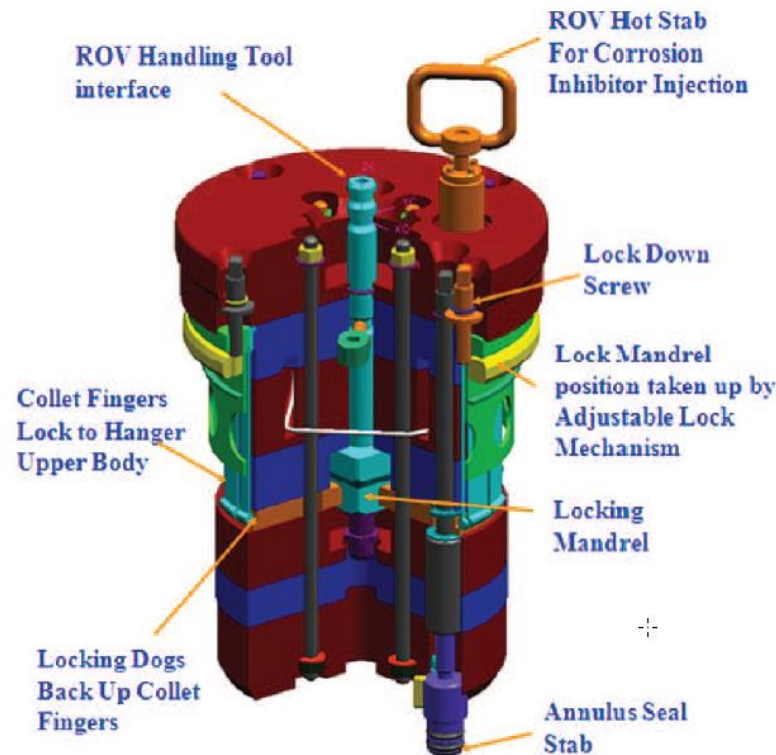

Figure 22-36 ROV-Operated Tree Cap (Courtesy of FMC)

Subsea control module

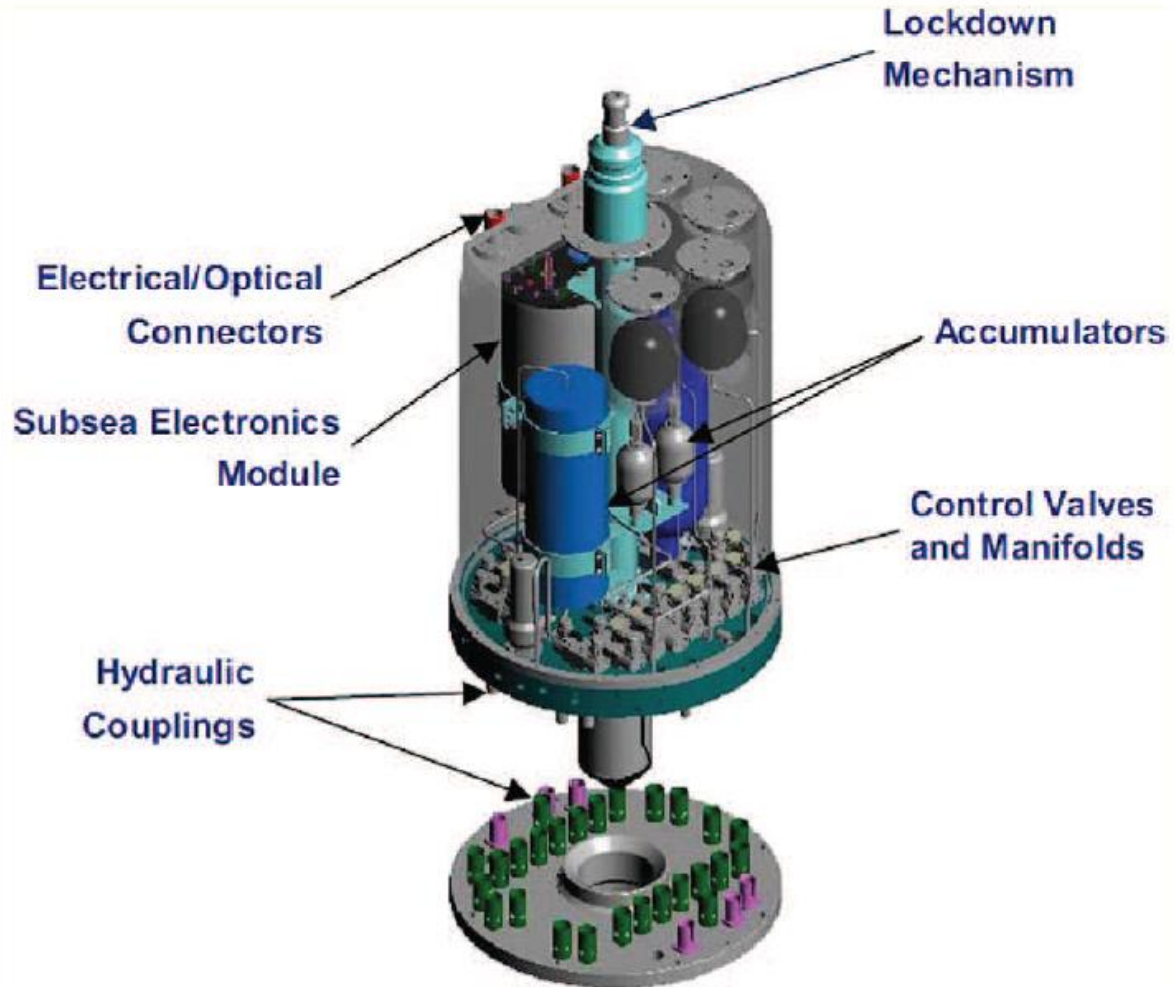

Figure 22-37 SCM Configuration

P and T transmitter

- pressure and temperature sensors are placed in the annulus and production bore and upstream and downstream of the choke.



Figure 22-38 PTT Located on a Subsea Xmas Tree

Chemical injection

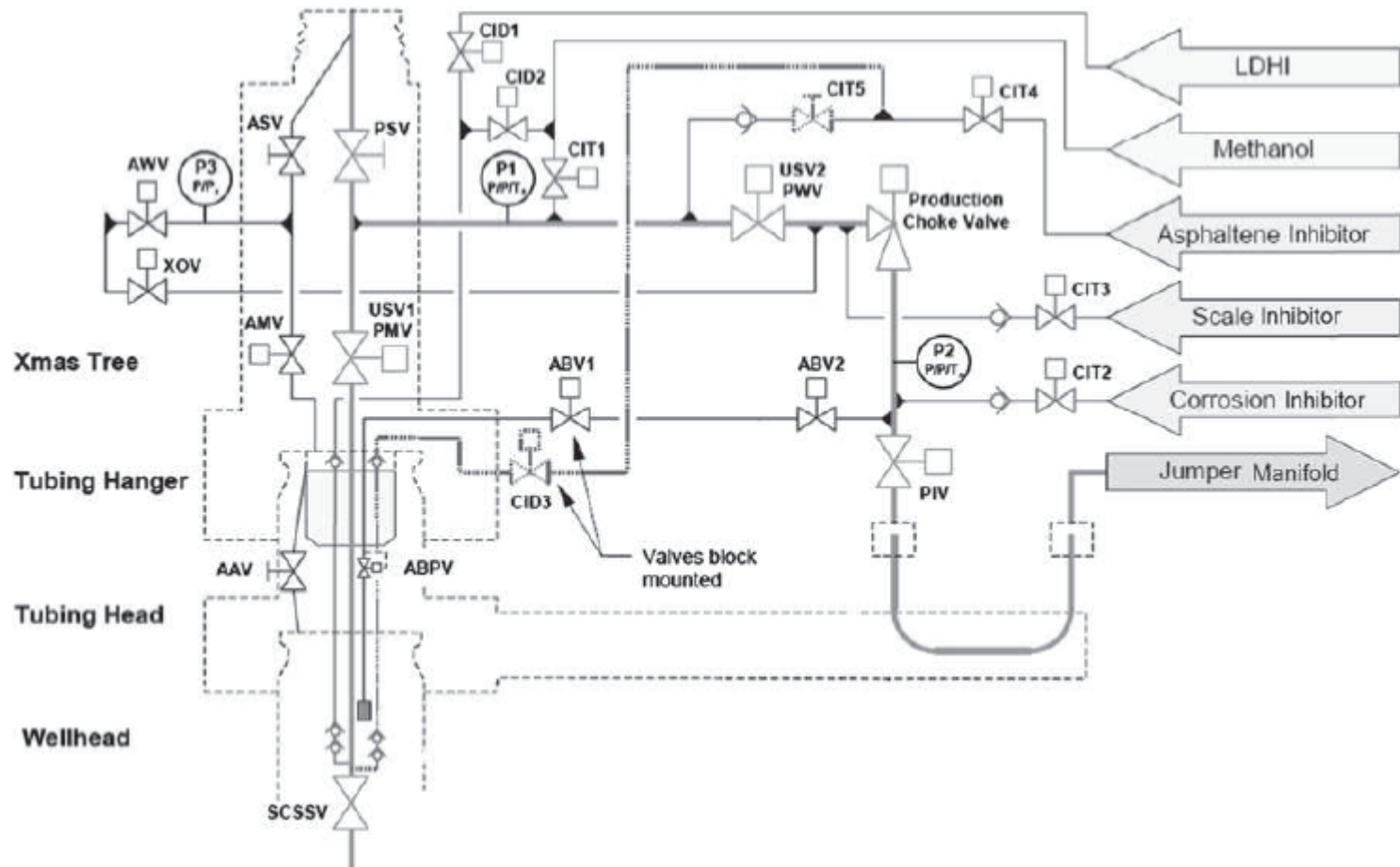

Figure 22-40 Example of Chemical Injection Design for Subsea Xmas Tree

Protection

- Cathodic protection is electrochemical protection that functions by making the metal surface of an electrochemical cell into a cathode that can decrease the corrosion potential to an acceptable level.
- The trees and wellhead require corrosion coatings and thermal insulation to enable sufficient cooldown time in the event of a production stoppage.
 - : to have sufficient time to perform preservation sequence
 - : to avoid dramatic consequences of hydrate formation

Installation



Figure 22-42 Tree Installation by Drill Pipe (Left) and Rig Winch (Right)

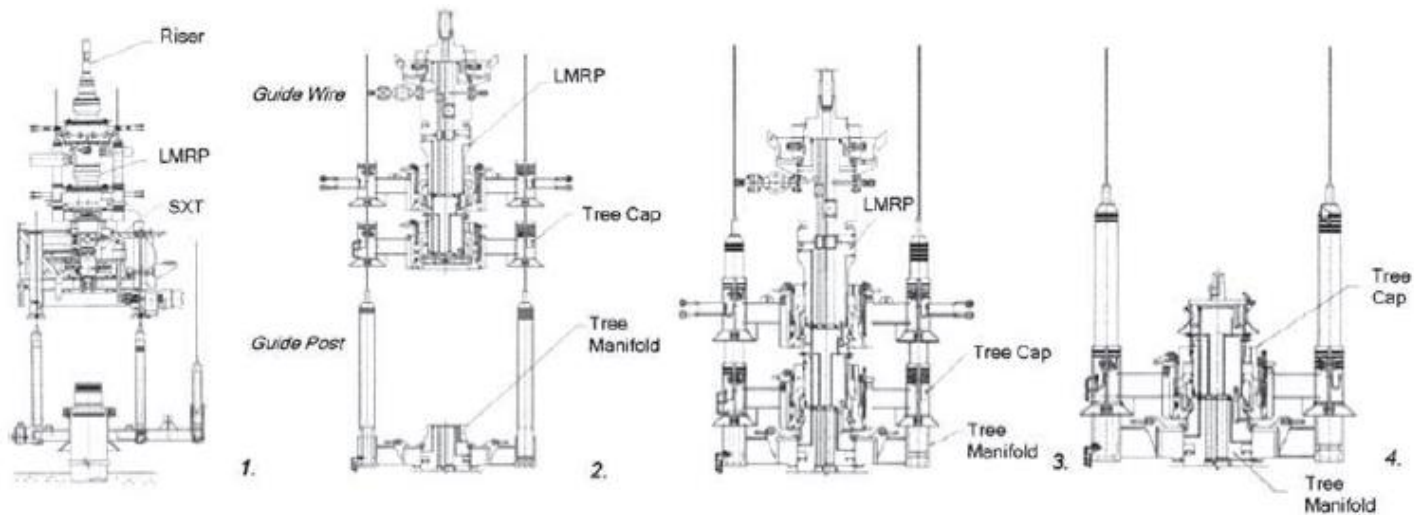

Figure 22-44 Vertical Xmas Tree Installation by Drill Pipe

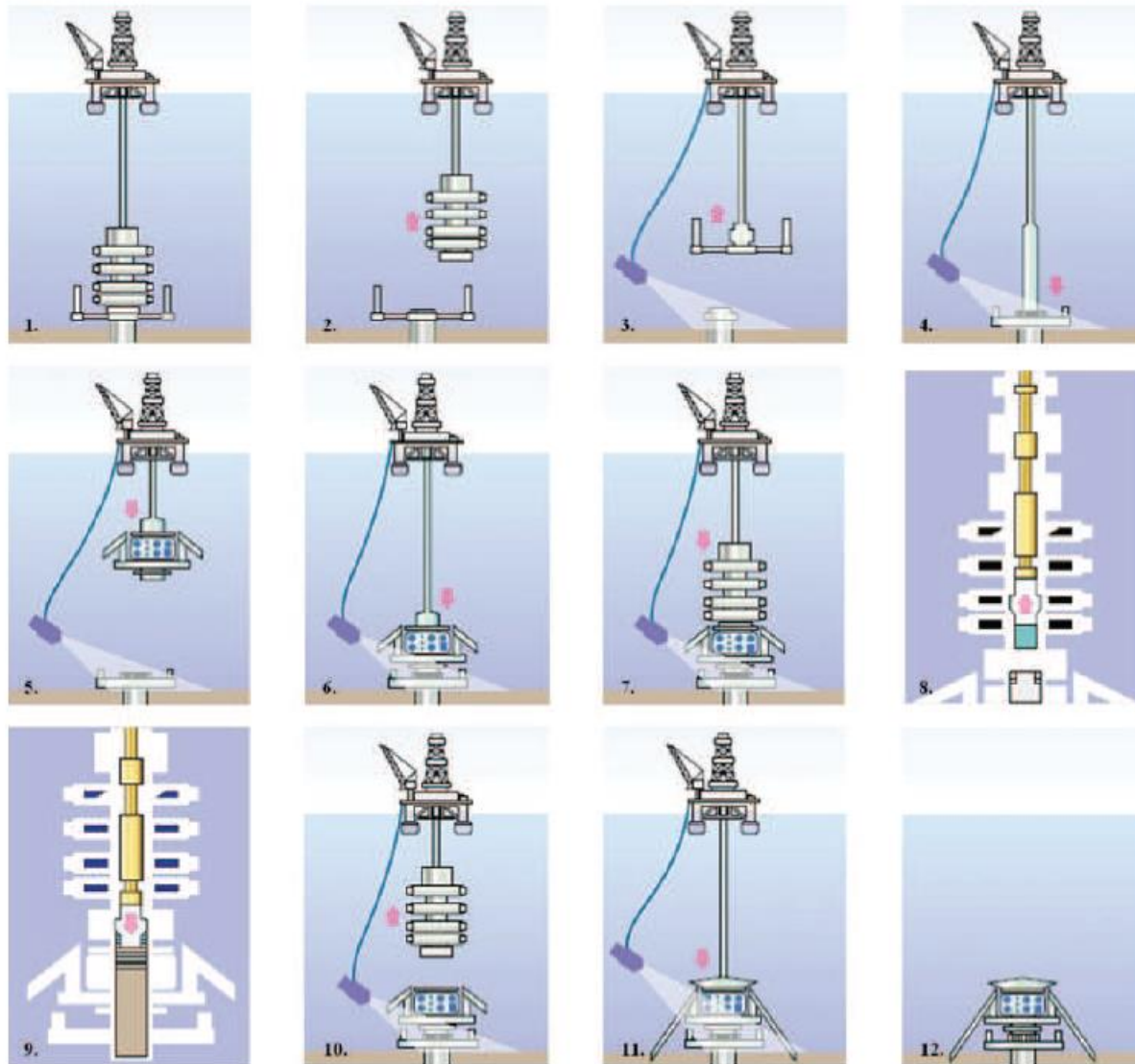

Figure 22-45 Horizontal Xmas Tree Installation Process (Courtesy of Schlumberger)



해저 배관 제작 및 설치

Subsea pipelines

- Normally, the term “subsea flowlines” is used to describe the subsea pipelines carrying oil and gas products from the wellhead to the riser foot.

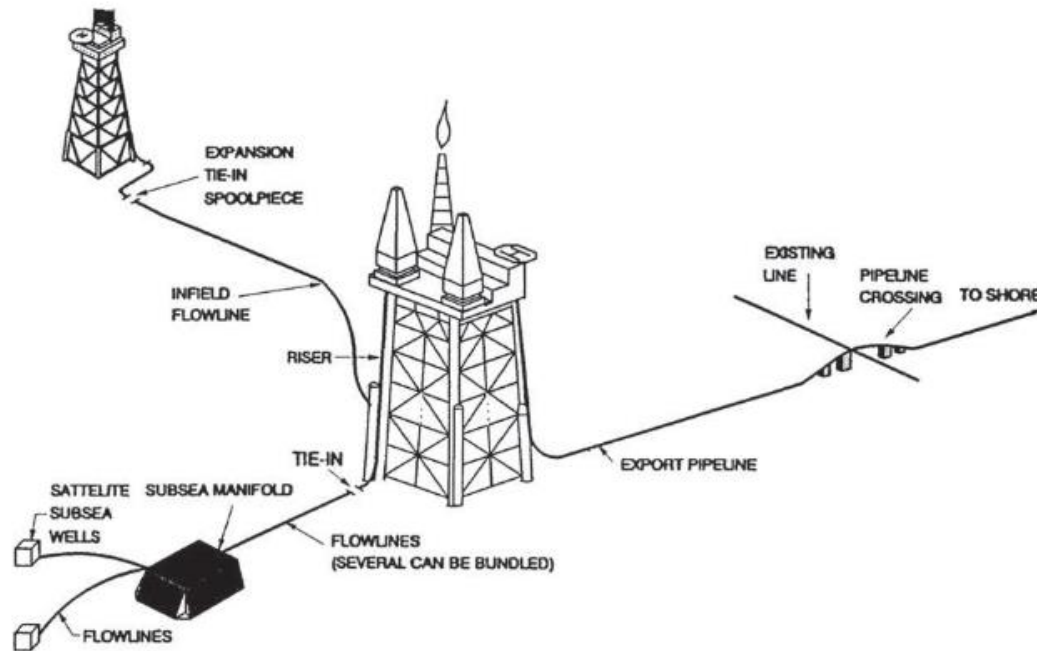

Figure 27-1 Application of Subsea Pipelines

Design process

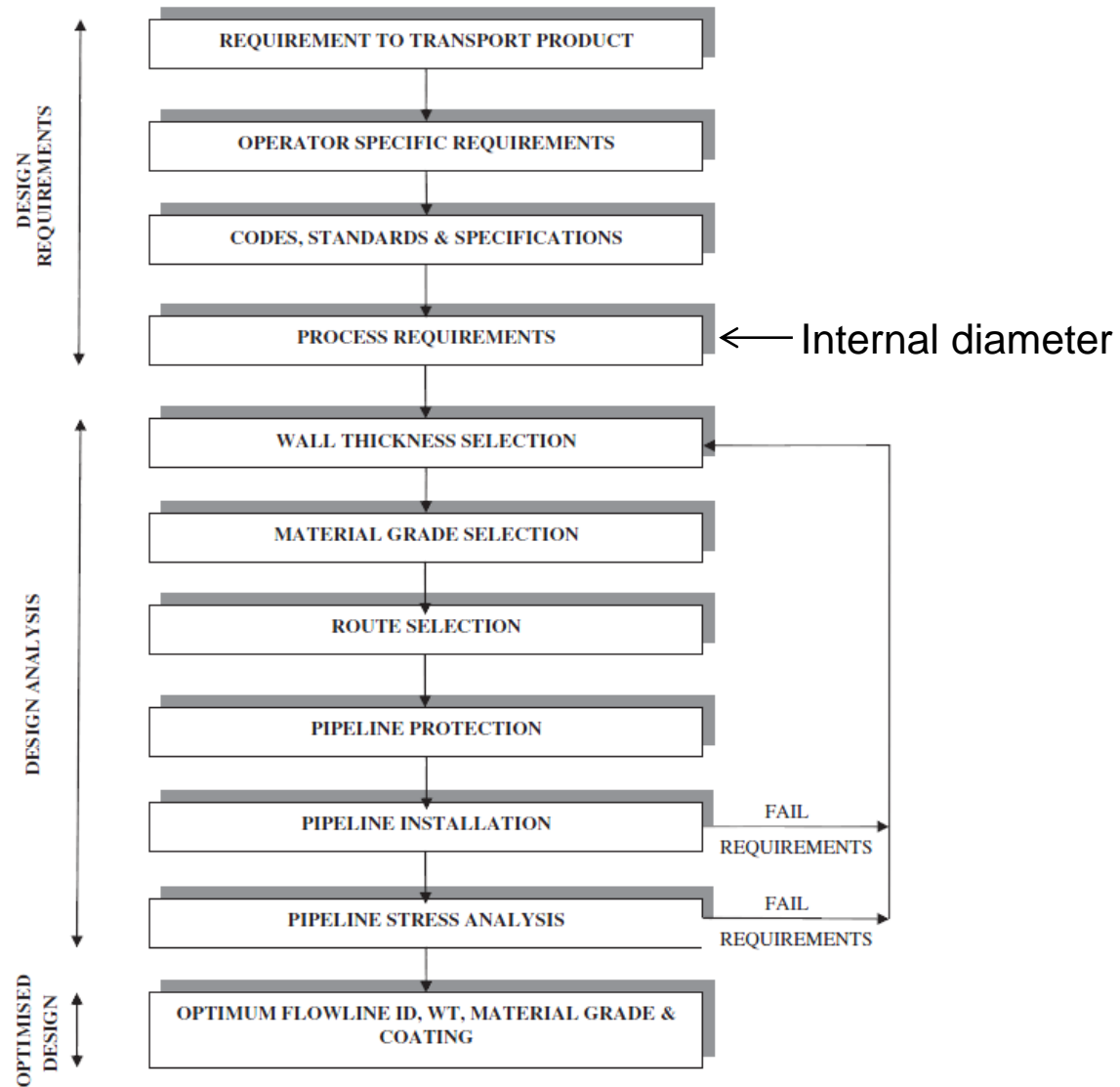

Figure 27-2 Subsea Pipeline Design Process

Design analysis

- Wall thickness analysis

: The wall-thickness level for pipelines should be able to withstand pressure and pressure effect (hoop and burst strength)

: A difference of internal pressure and external pressure in a pipeline produces stresses in the wall of a pipeline. These stresses are the longitudinal stress σ_L , the hoop stress σ_H , and the radial stress σ_R .

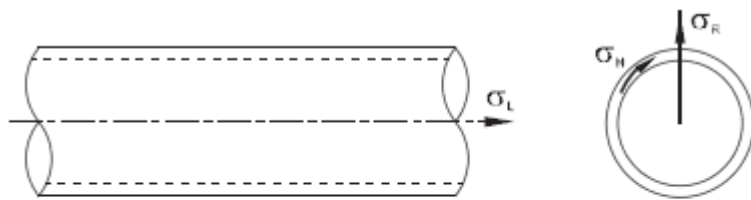

Longitudinal stress, σ_L

Hoop stress, σ_H

Radial stress, σ_R

Figure 27-4 Definitions of Pipe Wall Stress

$$\begin{aligned}
 \sigma_R &= \frac{p_i r_i^2 - p_e r_e^2}{r_e^2 - r_i^2} - \frac{r_i^2 r_e^2}{r^2 (r_e^2 - r_i^2)} (p_i - p_e) \\
 \sigma_H &= \frac{p_i r_i^2 - p_e r_e^2}{r_e^2 - r_i^2} + \frac{r_i^2 r_e^2}{r^2 (r_e^2 - r_i^2)} (p_i - p_e) \\
 \sigma_L &= \frac{p_i r_i^2 - p_e r_e^2}{r_e^2 - r_i^2} + \frac{F_{ext}}{\pi (r_e^2 - r_i^2)} = \text{constant} \\
 \sigma_R + \sigma_H &= 2 \frac{p_i r_i^2 - p_e r_e^2}{r_e^2 - r_i^2} = \text{constant}
 \end{aligned}
 \tag{27-1}$$

On-bottom stability analysis

- Subsea pipelines resting on the seabed are subject to fluid loading from both waves and steady currents.
- For regions of the seabed where damage may result from vertical or lateral movement of the pipeline, it is a design requirement for the pipe weight to be sufficient to ensure stability under the worst possible environmental conditions.
- In most cases this weight is provided by a concrete coating on the pipeline. In some circumstances the pipeline may be allowed to move laterally if provided stress limits are not exceeded.
- The wave and current data must be based on extreme conditions. For example, the wave with a probability of occurring only once in 100 years is often used for the operational lifetime of a pipeline.

- For the pipeline to be stable on the seabed, the following relationship must be satisfied:

$$\gamma(F_D - F_I) \leq \mu(W_{\text{sub}} - F_L) \quad (27-10)$$

where

γ : factor of safety, normally not to be taken as less than 1.1;

F_D : hydrodynamic drag force per unit length (vector);

F_I : hydrodynamic inertia force per unit length (vector);

μ : lateral soil friction coefficient;

W_{sub} : submerged pipe weight per unit length (vector);

F_L : hydrodynamic lift force per unit length (vector).

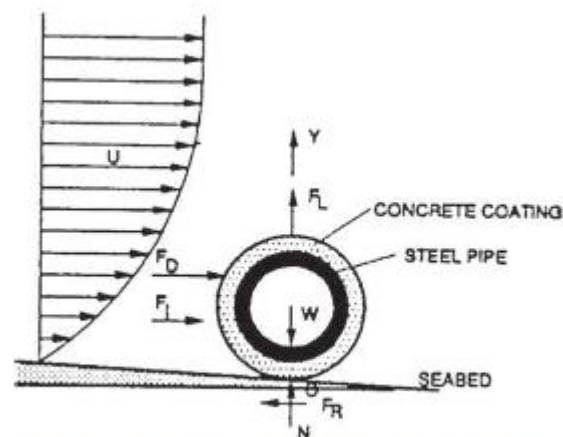

Figure 27-7 Subsea Pipeline Stability Analysis

Free span analysis

- Over a rough seabed or on a seabed subject to scour, pipeline spanning can occur when contact between the pipeline and seabed is lost over an appreciable distance.
- It needs to evaluate an allowable free-span length

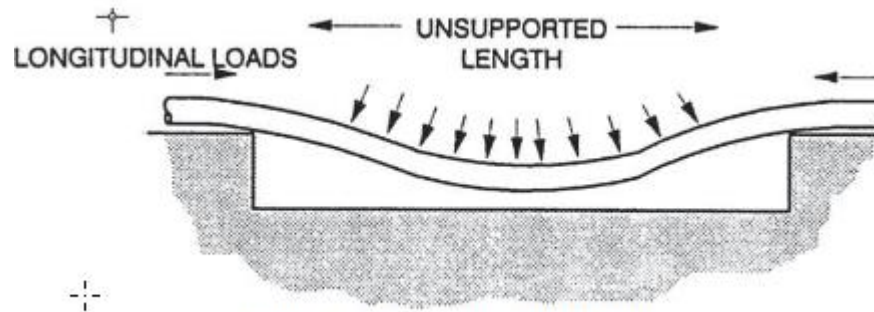
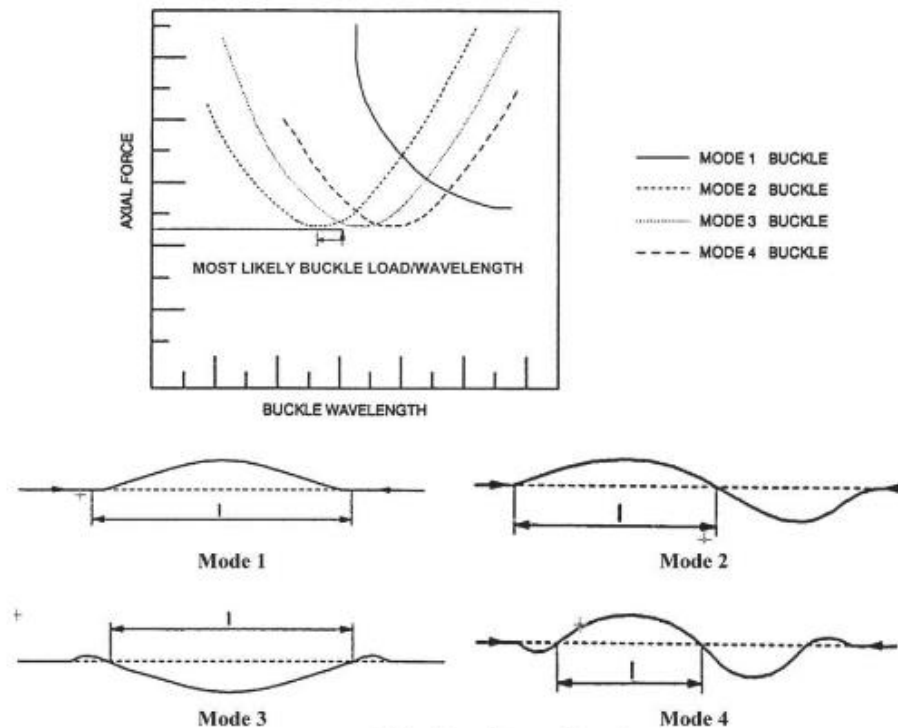

Figure 27-8 Pipeline Span Analysis

Global buckling analysis

- Global buckling of a pipeline occurs when the effective compressible force within the line becomes so great that the line has to deflect and, hence, reduces these axial loads.
- Analysis will be performed to identify whether the global buckling is likely to occur



Pipeline installation

- In early days, the pipeline was fabricated at beach and towed to the project field by a tug boat.
- Most widely used installation method is using a pipeline installation vessel which can weld pipe joints on the deck and lower the pipes by releasing the pipes from the tensioners while moving the vessel.
- Depending on the pipeline's profile from the vessel to the sea floor, it is called S-lay or J-lay.
- Another installation method is to fabricate the pipeline at spool base near beach and reel the pipe onto the reel ship. Then the reel ship carry the reeled pipe to the project field and lay by unspooling the pipes.

- The four pipeline installation methods

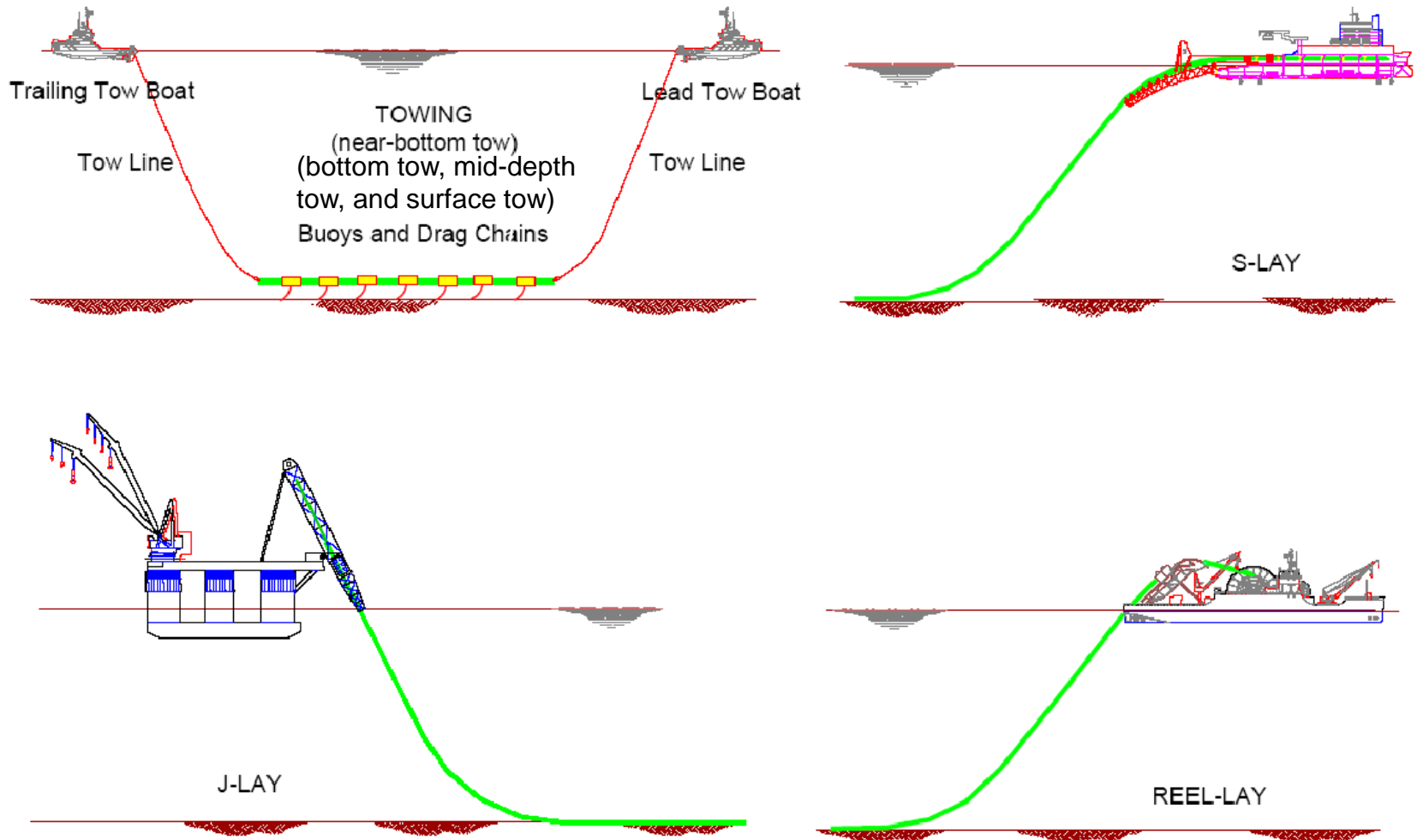

Pipeline installation

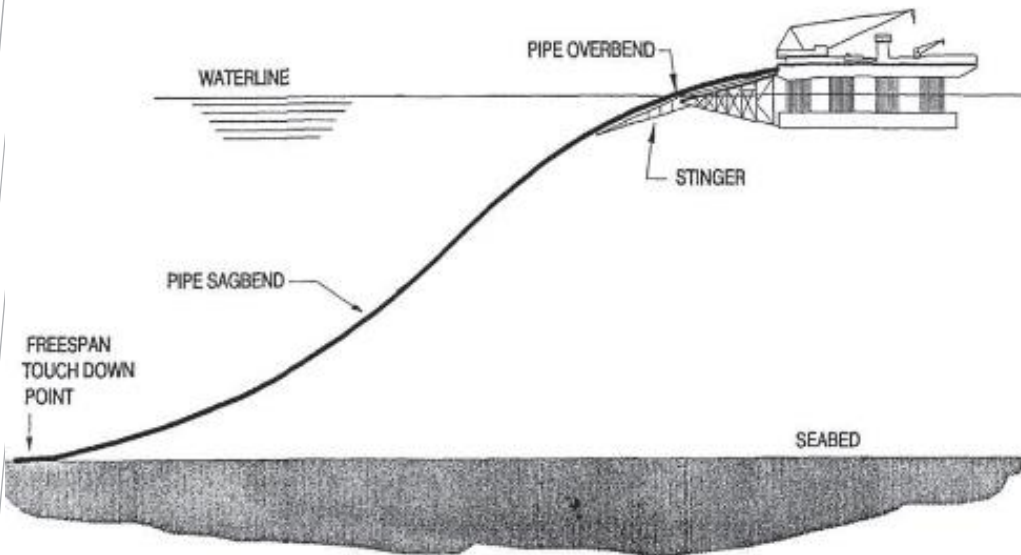
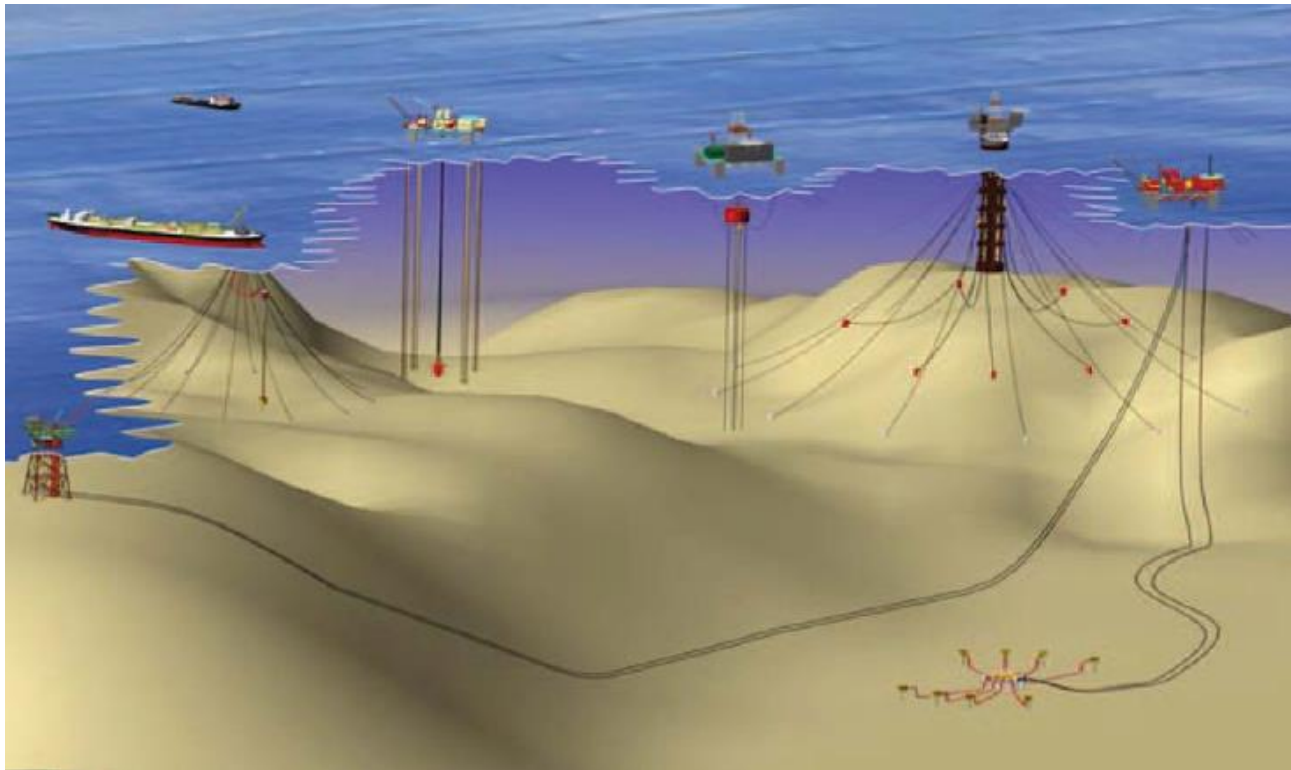

Figure 27-11 Typical Pipe Configuration during S-Lay Pipeline Installation



Production risers

- Steel catenary risers (SCRs),
- Top tensioned risers (TTRs),
- Flexible risers,
- Hybrid risers.



Steel Catenary Risers (SCRs)

- SCRs clearly have similarities with free-hanging flexible risers, being horizontal at the lower end and generally within about 20° of the vertical at the top end.
- The SCR is a cost-effective alternative for oil and gas export and for water injection lines on deepwater fields, where the large-diameter flexible risers present technical and economic limitations.
- The SCR is sensitive to waves and current due to the normally low level of effective tension on the riser. The fatigue damage induced by vortex-induced vibrations (VIVs) can be fatal to the riser.

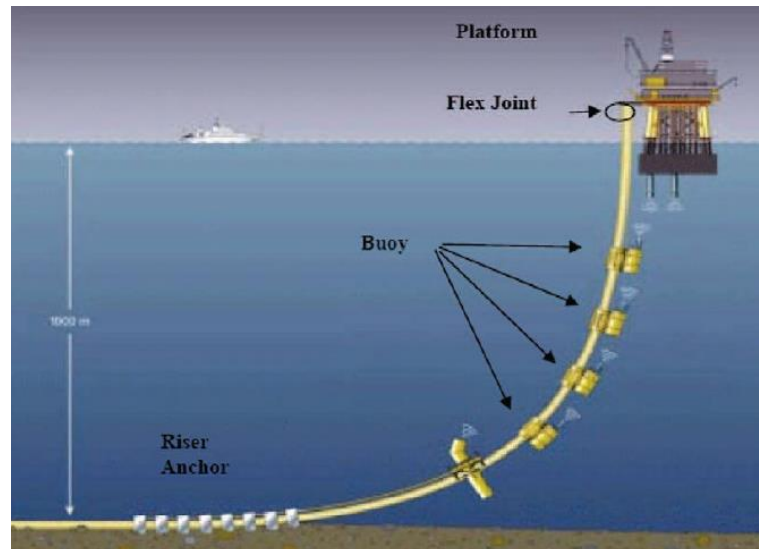

Top Tensioned Risers (TTRs)

- TTRs are long circular cylinders used to link the seabed to a floating platform.
- The risers are provided with tensioners at the top to maintain the angles at the top and bottom under the environmental loading. The risers often appear in a group arranged in a rectangular or circular array.

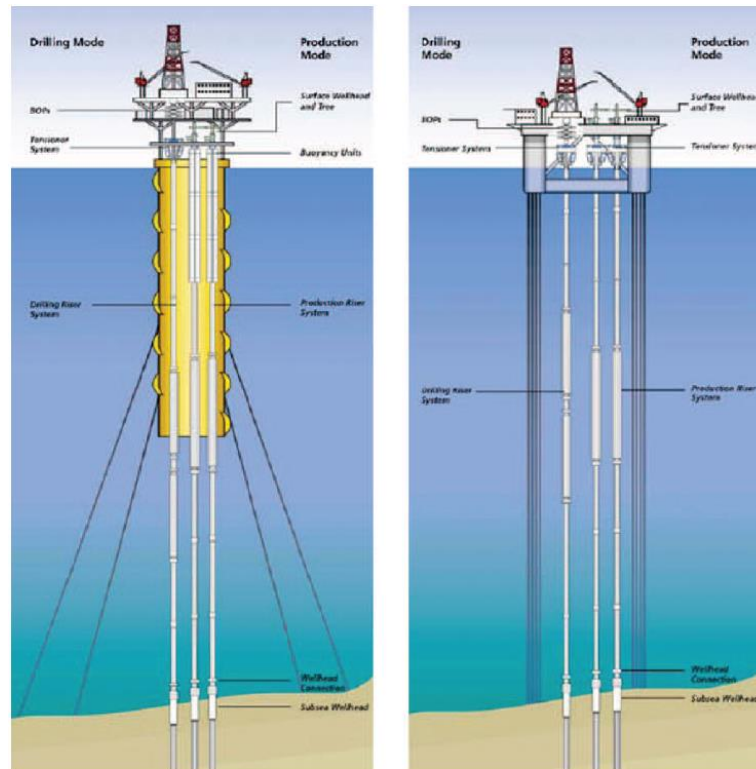

Figure 26-3 Top Tensioned Risers Used on Spar and TLP [8]

Flexible Risers

- Flexible risers are multiple-layer composite pipes with relative bending stiffness, to provide performance that is more compliant.
- Flexible pipes were found to be ideally suited for offshore applications in the form of production and export risers, as well as flowlines.
- The main characteristic of a flexible pipe is its low relative bending to axial stiffness. This characteristic is achieved through the use of a number of layers of different materials in the pipe wall fabrication.

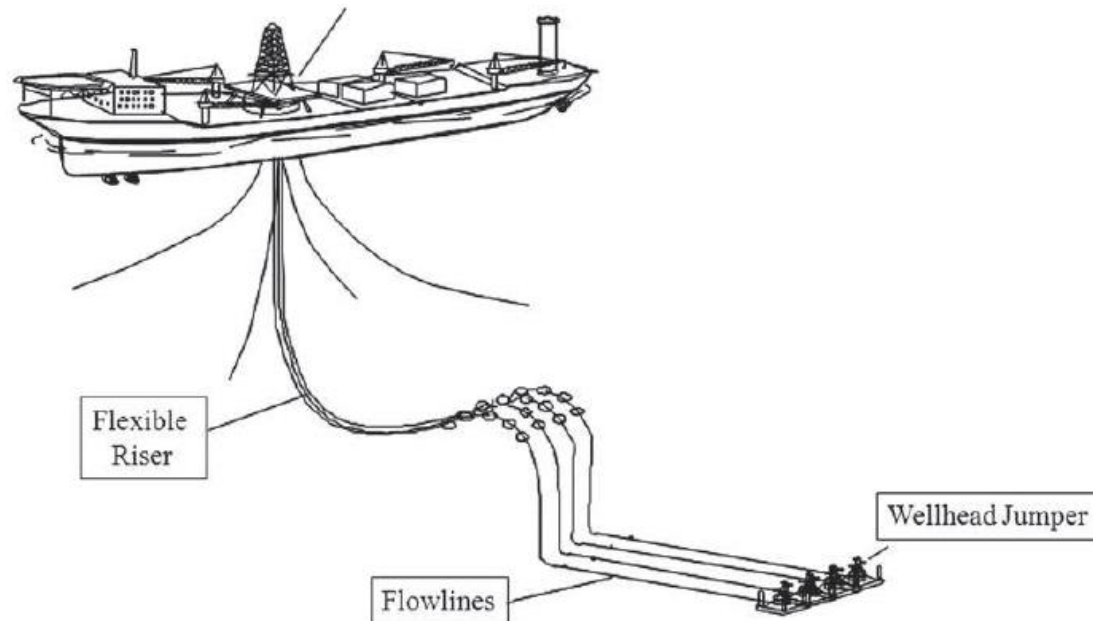
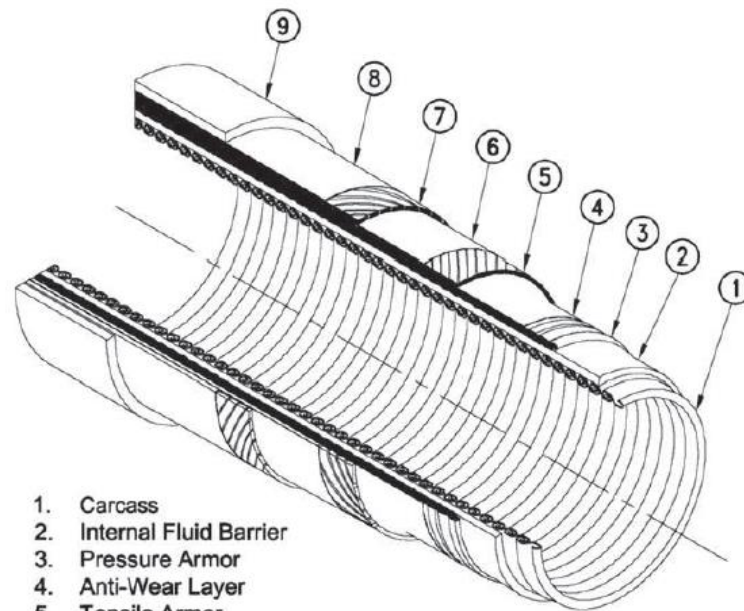

Figure 26-4 Flexible Riser Diagram

- The flexible pipe structure is composed of several layers (e.g., carcass) made of stainless steel to resist external pressure.
- The internal sheath acts as an internal fluid containment barrier, the pressure armor is made of carbon steel to resist hoop pressure, the tensile armor is made of carbon steel to resist tensile loading, and the external sheath is a kind of external fluid barrier.



1. Carcass
2. Internal Fluid Barrier
3. Pressure Armor
4. Anti-Wear Layer
5. Tensile Armor
6. Anti-Wear Layer
7. Armor Wire
8. Anti-Birdcaging Layer
9. External Fluid Barrier

Figure 26-18 Typical Cross Section of an Unbonded Flexible Pipe [29]

Hybrid riser

- The concept of a hybrid riser was developed based on the TTRs. Its principal feature is that it accommodates relative motion between a floating structure and a rigid metal riser, by connecting them with flexible jumpers.
- The lines are attached to hard piping on the base, which provides a connection to the subsea flowlines, and terminates in goosenecks some 30 to 50 m below the water surface.

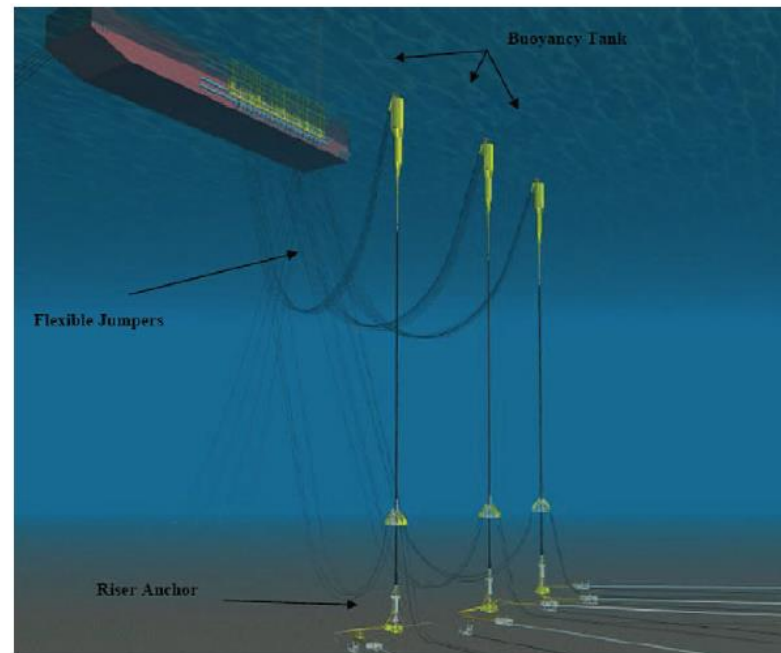

Figure 26-6 Bundled Hybrid Riser Diagram

Main components

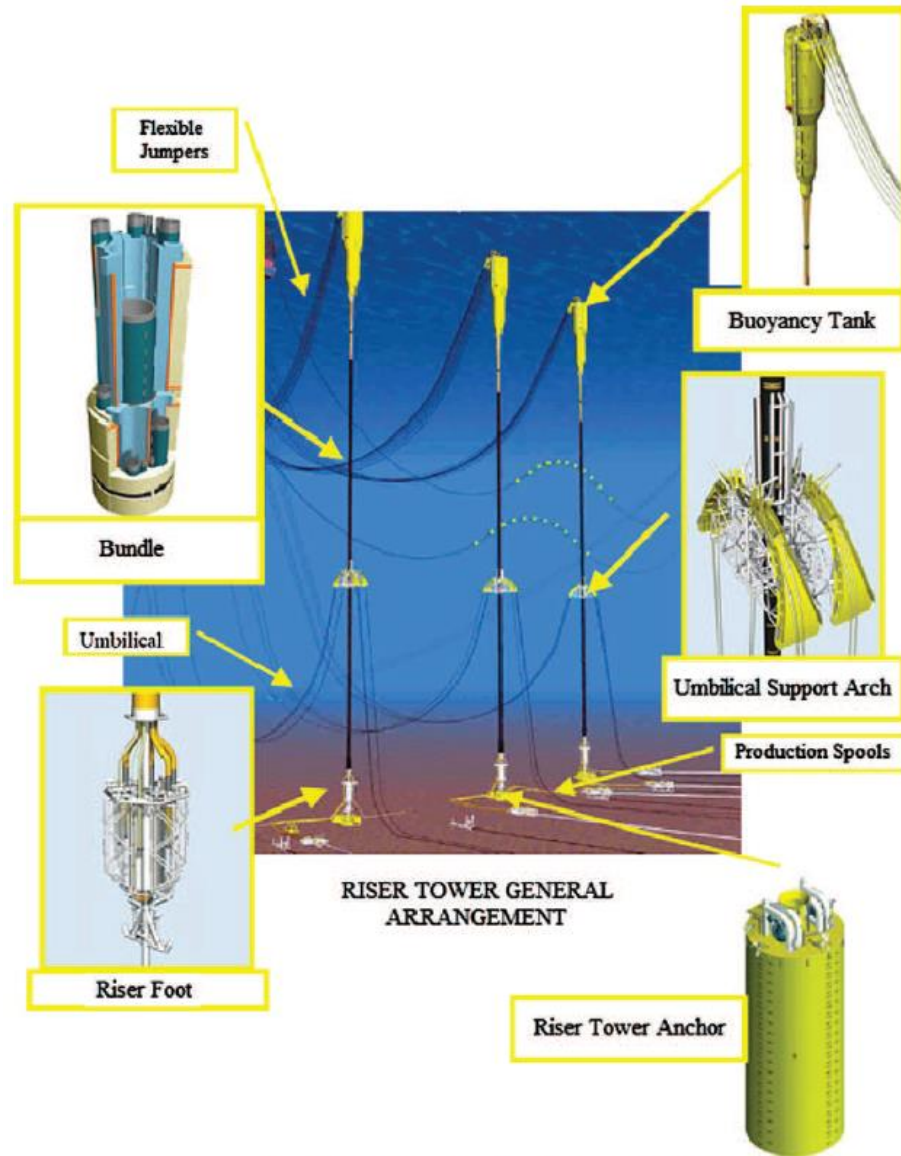

Figure 26-22 Hybrid Riser Towers at the Girassol Field

Hydraulic Power Unit (HPU)

- Provides system hydraulic pressure
- Stores control fluid energy
- Supplies clean hydraulic fluid
- Regulates supply pressure
- Sends status information to the MCS (Master Control Station)
- Allows remote or local control



Subsea Control Pod

- Subsea control center
- Executes commands from the surface
- Features
 - : Must be fully retrievable
 - : Receives and sends signals to MCS
 - : Tracks internal status and transmits to the MCS
 - : Functions subsea valves
 - : Monitors subsea sensors
 - : Re-configuration from topside
- May operate 18 – 24 hydraulic functions
- May monitor 8 – 10 remote sensor inputs



Subsea Umbilicals

- Provides link between surface (operator) and subsea equipment
- Supplies hydraulic fluid to operate subsea valves and chokes
- Supplies electrical power to operate subsea electronics
- Transmits electronic signals to execute operational commands subsea
- Returns electronic data to the surface from subsea instrumentation

Subsea umbilicals

- Design Considerations:
 - : Water depth
 - : Tie-back type
 - : Tie-back length
 - : Service life
 - : Installation
 - : Chemical compatibility
 - : Flow rates
 - : Internal pressures
 - : Size of field



Umbilical Termination Assembly

- Umbilical Termination Assembly (UTA)
 - : Provides the subsea termination for the umbilical
 - : Can be the subsea distribution point for hydraulic fluid, electrical power, electronic signals, and injection chemicals
 - : Provides an interface for flying leads or SDUs
 - : Can be retrieved for maintenance

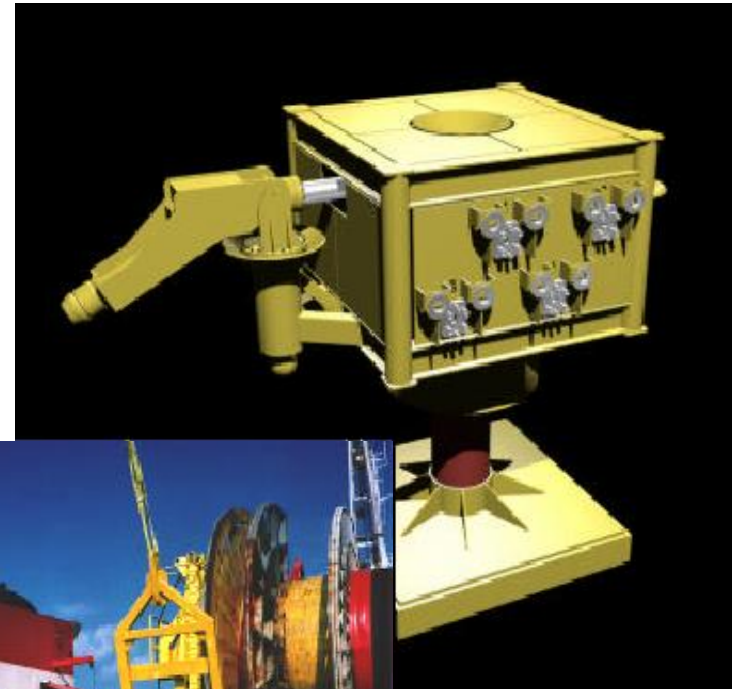



Thank you!