

Image courtesy of FMC Technologies

해저 공학

서유택

Objectives

- Understand the operation of subsea tie-backs on typical oil and large gas condensate developments.
- Understand the vulnerabilities of subsea systems.



Operating topsides or onshore

- It's a lot easier to picture what is happening within the process..



Operating subsea systems

- Understanding what is happening subsea requires experience and inference

Flowrate variation...

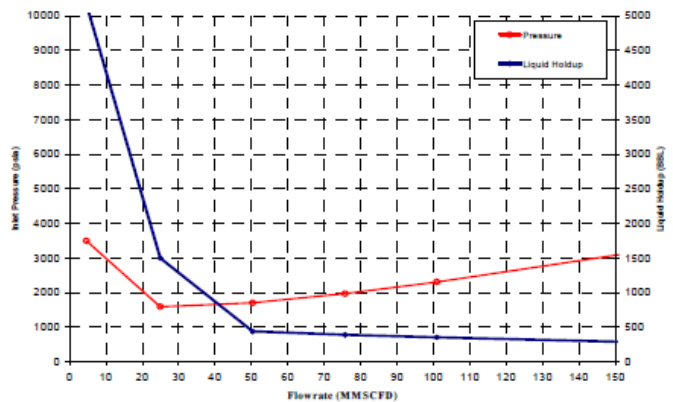

Pressure, Temperature ..

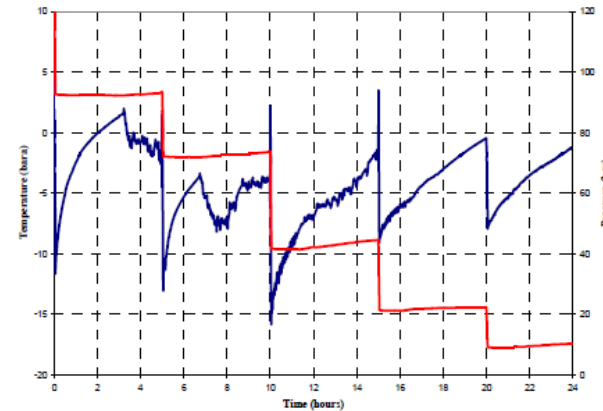

Terrain slugging...

Outlet Liquid Flowrate - Terrain Slugging

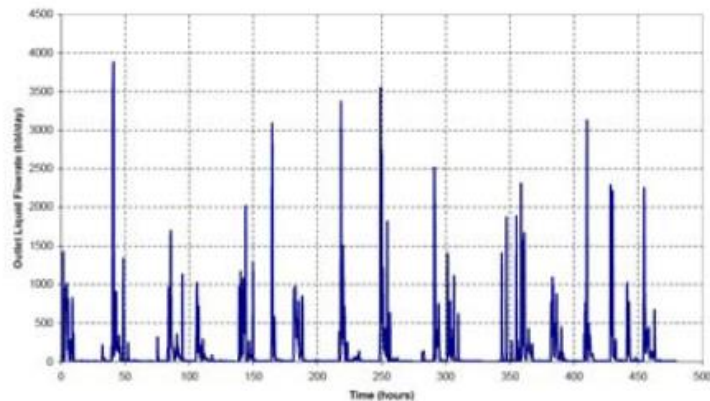

Operating subsea systems

- The transportation of raw well stream fluids presents additional challenges to operating subsea systems
 - Hydrates
 - Corrosion
 - Wax
 - Asphaltenes
 - Scale
 - Sand (erosion, transport, deposition)
 - Emulsion,
etc.

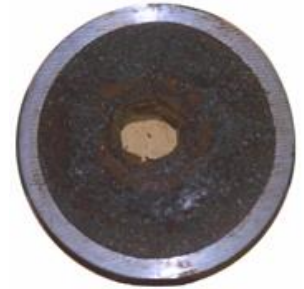

Subsea developments

- Let's assume two types of subsea production systems

Crude oil subsea tieback

- Crude oil field
- 2 wells tied back to existing platform 10km away
- Water depth 150m
- 20,000 bbl/day
- 2 * 6" flowlines
- Water injection required into reservoir

- Revenue \$2MM USD day

Gas tieback to LNG plant

- Gas condensate field
- 10 wells tied back to an LNG plant 150 km away
- Water depth 1200 m
- 1000 MMscfd
- 30" flowline
- Continuous MEG injection required at subsea chokes.

- Revenue \$6 MM USD day

Operating envelope

- Boundaries of the system to operate within

Crude oil subsea tieback

- Fluid composition:
 - Gas Oil Ratio: 1000 scf/bbl
 - Water cut: 20%
- Temperature: 35~70 °C
- Pressure: 30 ~ 80 bar
- Rates: 7000 ~ 20000 bbl/day

Typical operating envelope issues:

- Low rates lead to wax deposition
- Increased GOR leads to severe slugging

Gas tieback to LNG plant

- Fluid composition:
 - Condensate gas Ratio: 5 bbl/MMscf
 - Water gas ratio: 1 bbl/MMscf
- Temperature: 3~130 °C
- Pressure: 75 ~ 300 bar
- Rates: 500 ~ 1000 MMscfd

Typical operating envelope issues:

- Low rates lead to liquid accumulation
- Increased WGR could lead to hydrate blockage

Subsea steady-state operations

Following variables to be relatively constant with time:

- Well stream production rates
- Composition
- Arrival pressure & temperature

Many factors may result in a deviation from steady-state conditions

- Change in downstream offtake
- Well trip
- Change in ambient conditions (hydrate, wax issues)
- Increased water-cut

Recovery to steady state operation within the operating envelope may take from hours to months depending on the severity of the disturbance

Maintaining steady-state operation

Crude oil subsea tieback

- Flow control:
 - System operated at capacity, wellhead chokes fully open
 - Some choking topsides to maintain system pressure
- Typical disturbance
 - Topside trip: separator flooding after sand blockage
- Typical trend
 - Reservoir pressure decline, increasing watercut

Gas tieback to LNG plant

- Flow control:
 - Gas offtake at required rate
 - Subsea choking to maintain flowline operating pressure
- Typical disturbance
 - LNG plant trip: turbine failure
- Typical trend:
 - Wellhead pressure decline requiring opening of subsea chokes

Maintaining steady-state operation

Crude oil subsea tieback

- Designed to keep fluids hot
- Avoid hydrate formation
- Avoid wax formation

Gas tieback to LNG plant

- Designed to cool fluids down
- Reduce corrosion
- Reduce thermal cycling of long & large diameter flowlines

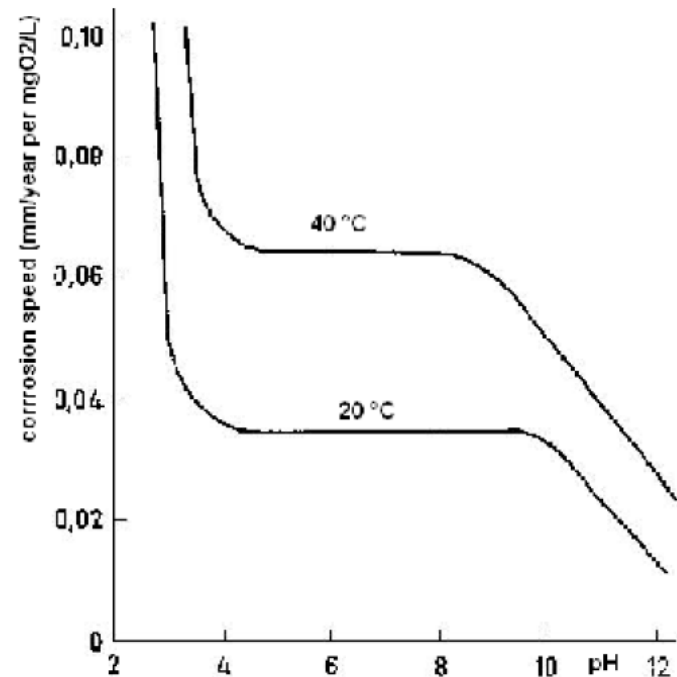

Subsea transient operations

Each subsea system will incorporate the following strategies

- Restart (warm, cold)
- Shutdowns (planned, unplanned)
- Ramp-up / ramp-down

Some operating strategies will be required only for specific systems

- Depressurization/repressurization
- Line packing
- Pigging
- Flowline pre-heating
- Chemical injection

These operations may be relatively straight forward, with the system robust to variations

OR

may be complex that require an experience to execute those safely & effectively

Shutdown

Crude oil subsea tieback

- Planned shutdown is followed by flowline depressurization
- Shallow water is warmer than deep water, this ensures flowline contents remain outside of the hydrate region once system is depressurized.
- Unplanned shutdown may require restart within given cool down time or require system depressurization.
- Failure to depressurize in sufficient time will increase risk of hydrate blockage

Gas tieback to LNG plant

- Planned shutdown is followed by additional MEG dosing at the subsea chokes to ensure any condensing water is adequately inhibited
- System pressure is maintained and flowline contents rely on previously injected MEG to remain outside of hydrate region
- Unplanned shutdown is not significant for robust system design and operations (i.e. continuous MEG injection is adhered to)

Restarts

Crude oil subsea tieback

- Hot oil circulation is required to heat flowline system prior to opening of wells and pressurization to normal operating pressure.
- Hot oil will be pumped through the flowline loop, required to meet a specified return temperature to ensure pipeline is warm enough to prevent hydrates upon pressurization.

Gas tieback to LNG plant

- In the event of depressurization of the flowline, well restart may require pressurization of the flowline.
- Typical well restart would be into a pressurized flowline. A minimum flowline pressure maybe prescribed for restarting wells.
- Well restarts may be accompanied by very low temperatures downstream of the subsea production choke.

Ramp-up/Ramp down

Crude oil subsea tieback

- Ramp-up & ramp down within operating envelope is readily achieved.

Gas tieback to LNG plant

- Ramp-down & ramp-up coordinated between subsea and onshore chokes to maintain normal operating pressure
- Ramp-down will starve flowline reception facilities of liquid
- Ramp-up will result in liquid surges with potential to flood reception facilities with liquid

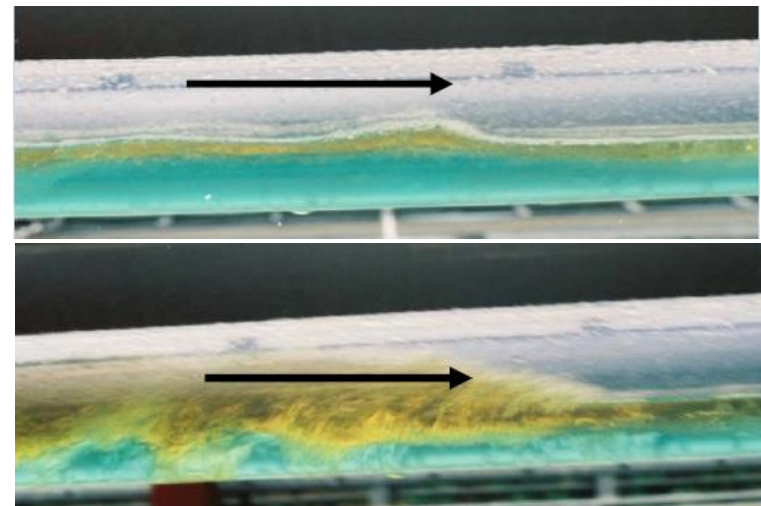
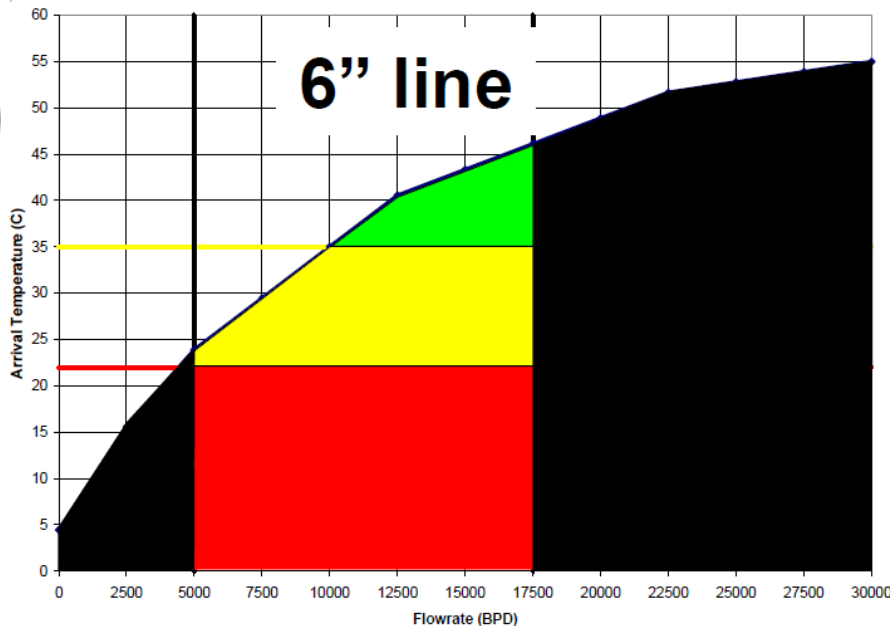

Depressurization/Repressurization

Crude oil subsea tieback

- Depressurization of a predominantly liquid filled system will require a relatively small release of liquid & liberated gas.
- Repressurization is likely a simple process of introducing well fluids back into the flowline.

Gas tieback to LNG plant

- Double sided depressurization (as required for hydrate remediation) can be a lengthy process (weeks) requiring balancing of pressure across the blockage.
- Repressurization may also be a lengthy process if an external gas source is required to achieve a minimum flowline pressure prior to a well restart.

Line Packing

Crude oil subsea tieback

- In a predominantly liquid filled system the pressure can be increased however this will not result in a substantially increased volume in the flowline
- Consequentially a shut-in at the subsea wells or on topsides will have a near immediate impact on the full system.

Gas tieback to LNG plant

- Line packing of a subsea gas-condensate flowline can be best imagined as treating the flowline as a balloon.
- Reduced offtake will increase the gas volume in the flowline due to increase in pressure.
- It may be possible to run an LNG plant for several hours based on linepack following a trip of the subsea system.
- It is important that line packing is considered as a part of the design phase so that sufficient allowances have been made for:
 - MEG injection
 - Choking onshore
 - Pressure protection system

Pigging (intelligent pigging or pipeline cleaning?)



Crude oil subsea tieback

- Generally short field life and low pressure system inspection pigging may only be required several times in field life. Control of pig speed simpler in a liquid system.
- Pipeline cleaning (round trip pigging) may be required on routine basis if wax deposition is an issue



Gas tieback to LNG plant

- Pigging a large subsea flowline hopefully is not a routine procedure. Complex and may incur significant production losses.
- Large control valves, subsea pig launcher and large pig receiver. Rigorous modeling required to determine strategy of controlling pig speed.
- Typically system designed to avoid non-intelligent pigging, however dumb pigging will be required prior to intelligent pigging

Chemical injection

Crude oil subsea tieback

- Chemical injection systems may be critical to maintain system performance. Scale inhibitor, wax inhibitor & corrosion inhibitor may all require continuous injection
- Monitoring of chemical injection system performance is important both for effectiveness of chemical treatment and cost management
- Introduction of new chemical products should only follow lab testing to verify compatibility



Gas tieback to LNG plant

- Continuous MEG injection can result in a large complex processing system in its own right
- MEG needs to be regenerated and reclaimed (to remove salts)



Recommendation

- Subsea systems present a unique and challenging array of operational challenges.
- Even if subsea systems look identical, differences in fluid composition or even water chemistry will influence the behavior & operation of a system.
- Understanding the basic theory behind Operating Procedures can significantly contribute to safe operations and maximizing uptime



Operation of subsea wells

1. Operating a subsea system is easy.
2. However safely and efficiently operating a subsea system, takes patience and needs robust design.
3. So what do these mean?
 - If you know how to operate an onshore or offshore platform or land based wells from a control room, then operating a subsea system is no different, therefore it is easy.
 - For an operator, the major difference between a subsea system and the rest is – You can't see it or touch it, to have a sense of how the subsea system is behaving.
 - What you have on the screen is what you have got!

Typical screen shot of a production well

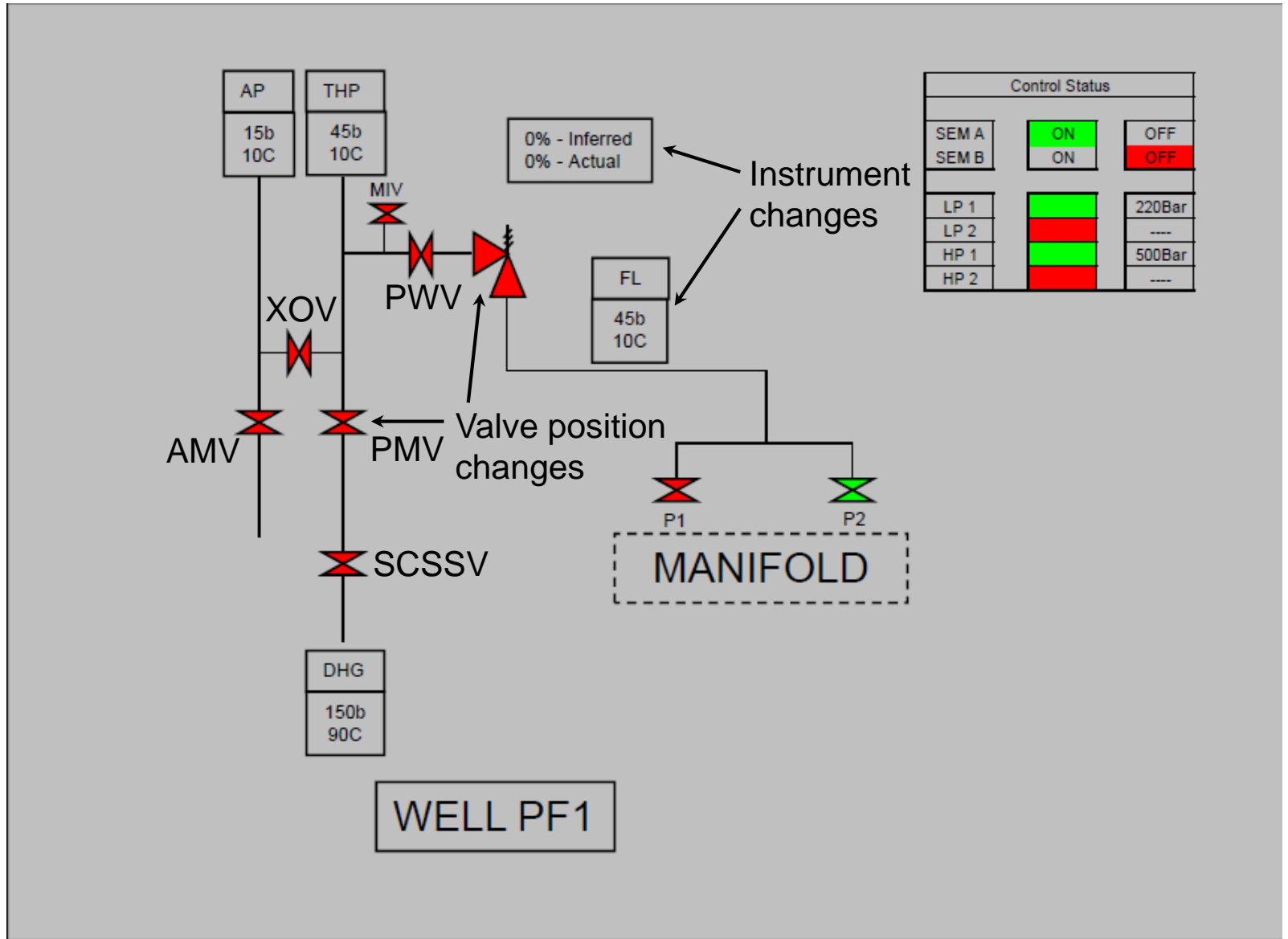

Opening a production well – MeOH flushing

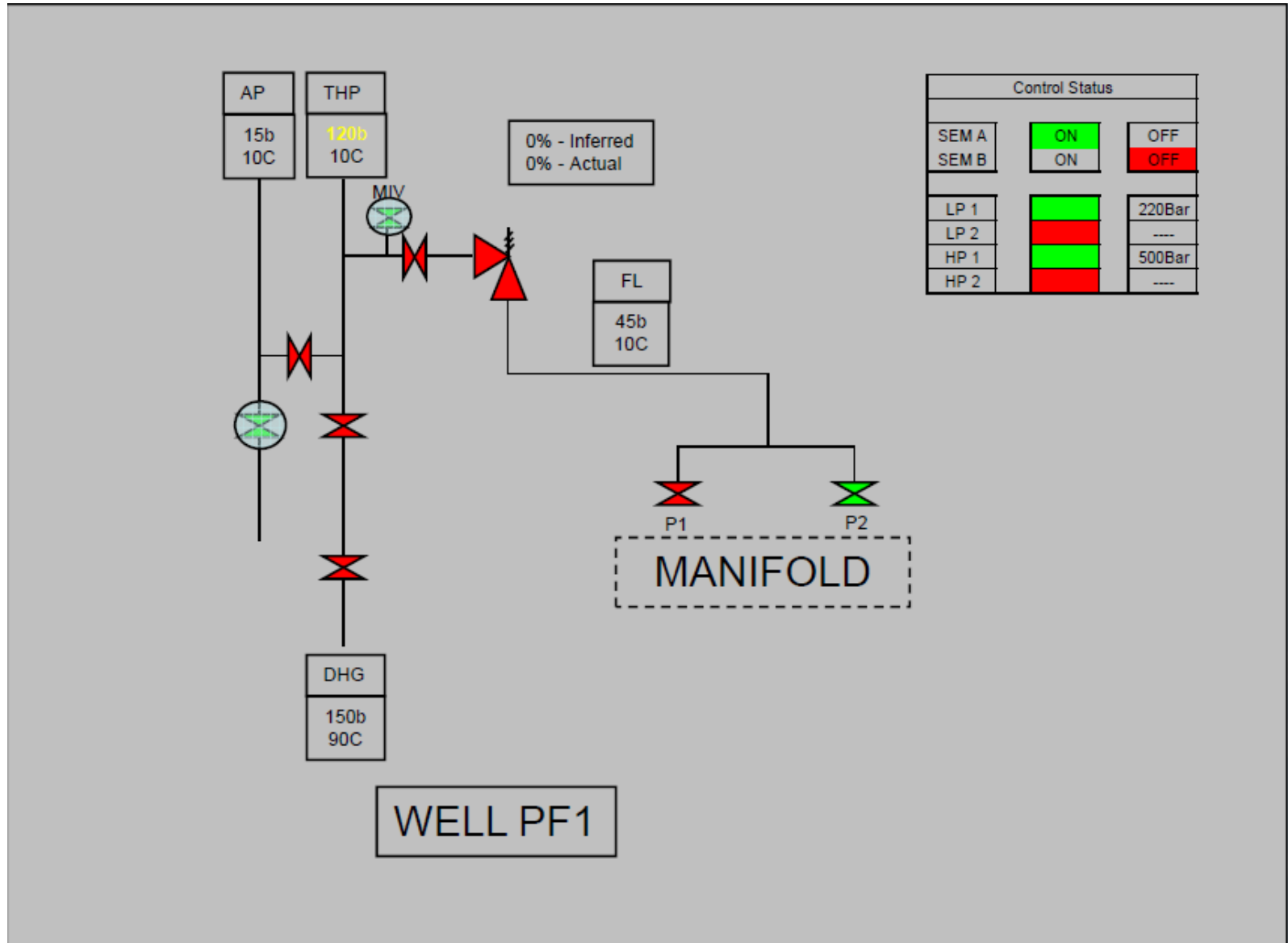

Opening a well 1 – PMV open

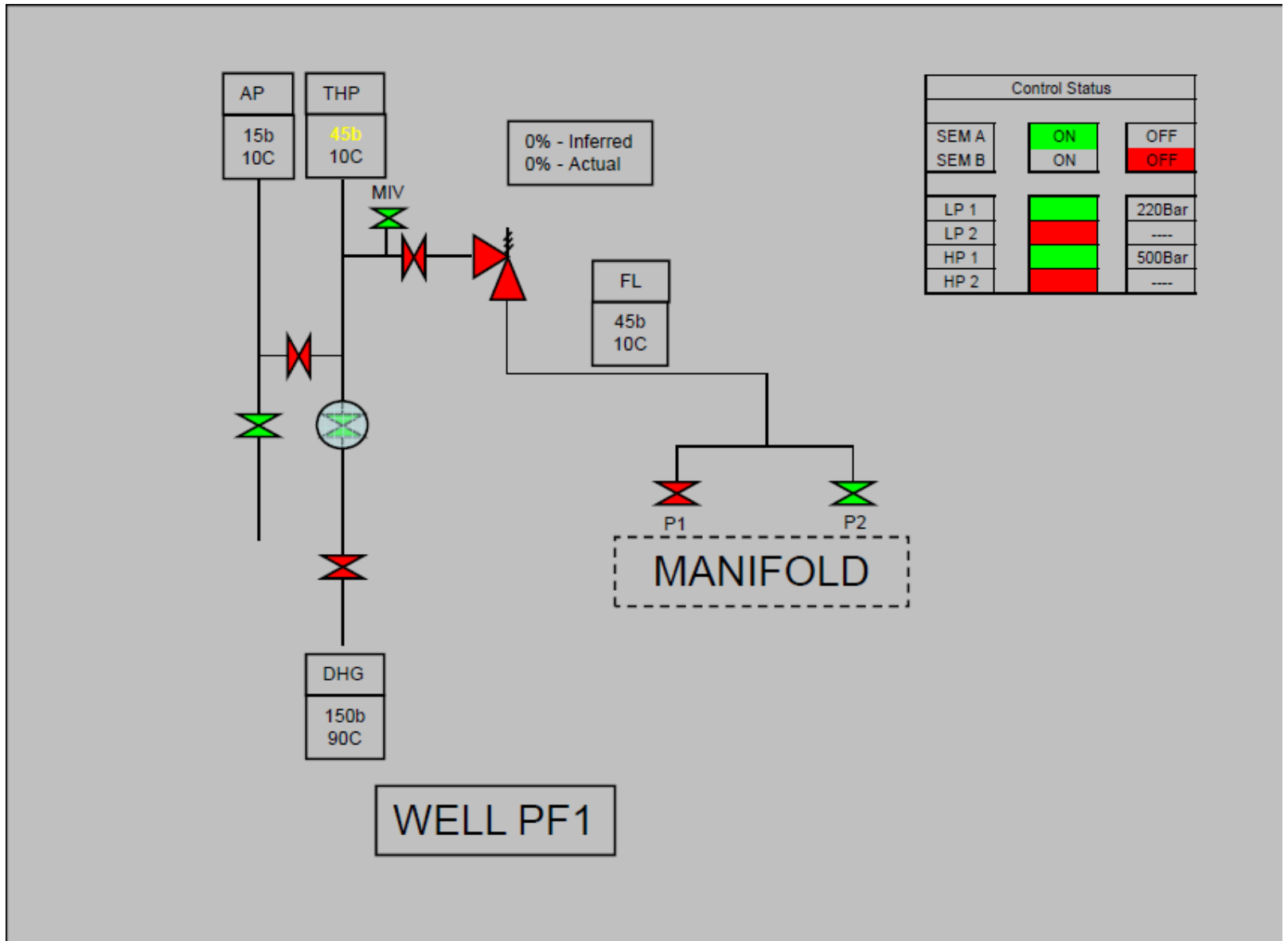

Opening a well 2 – MeOH flushing

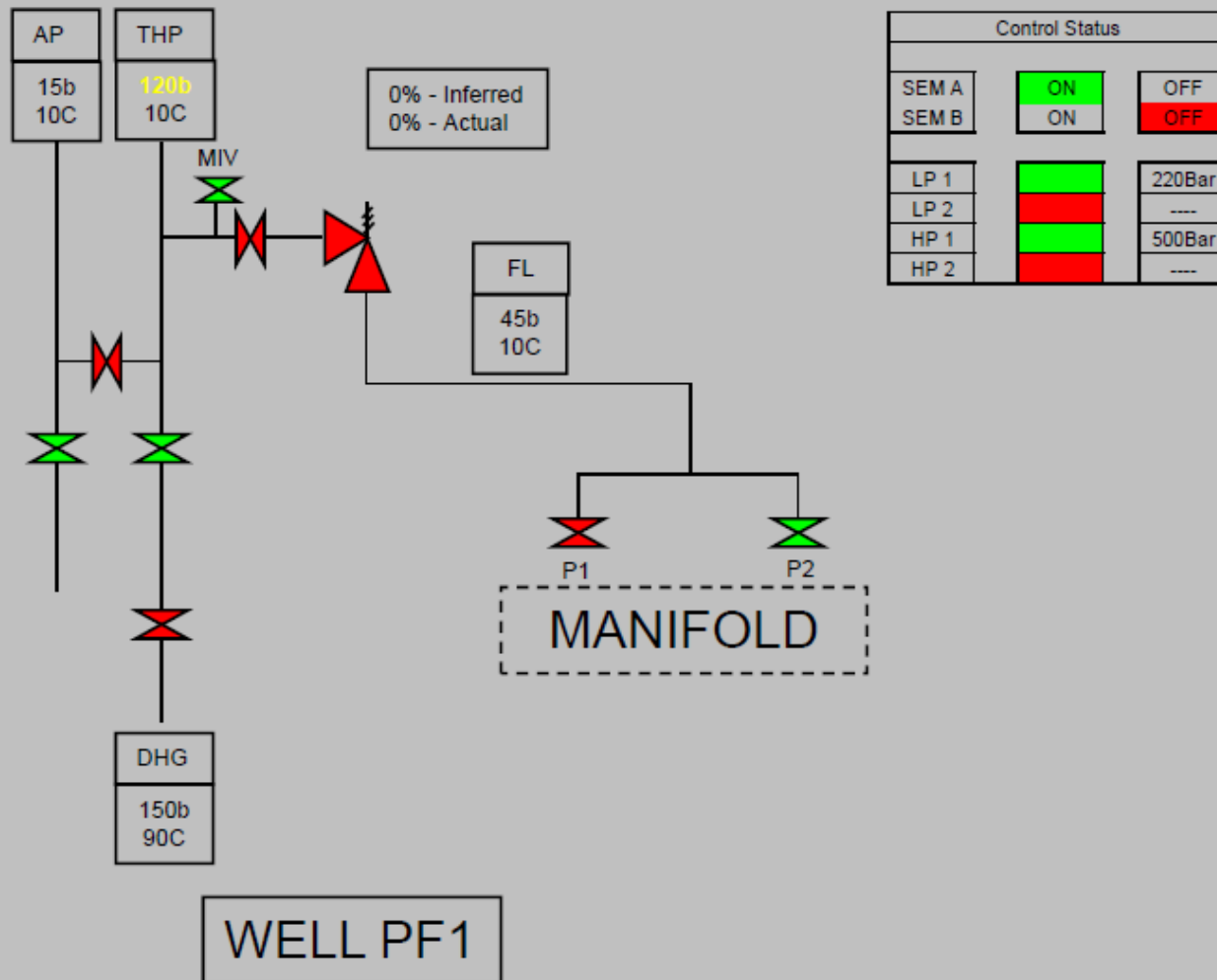

Opening a well 3 – SCSSV open, MIV close

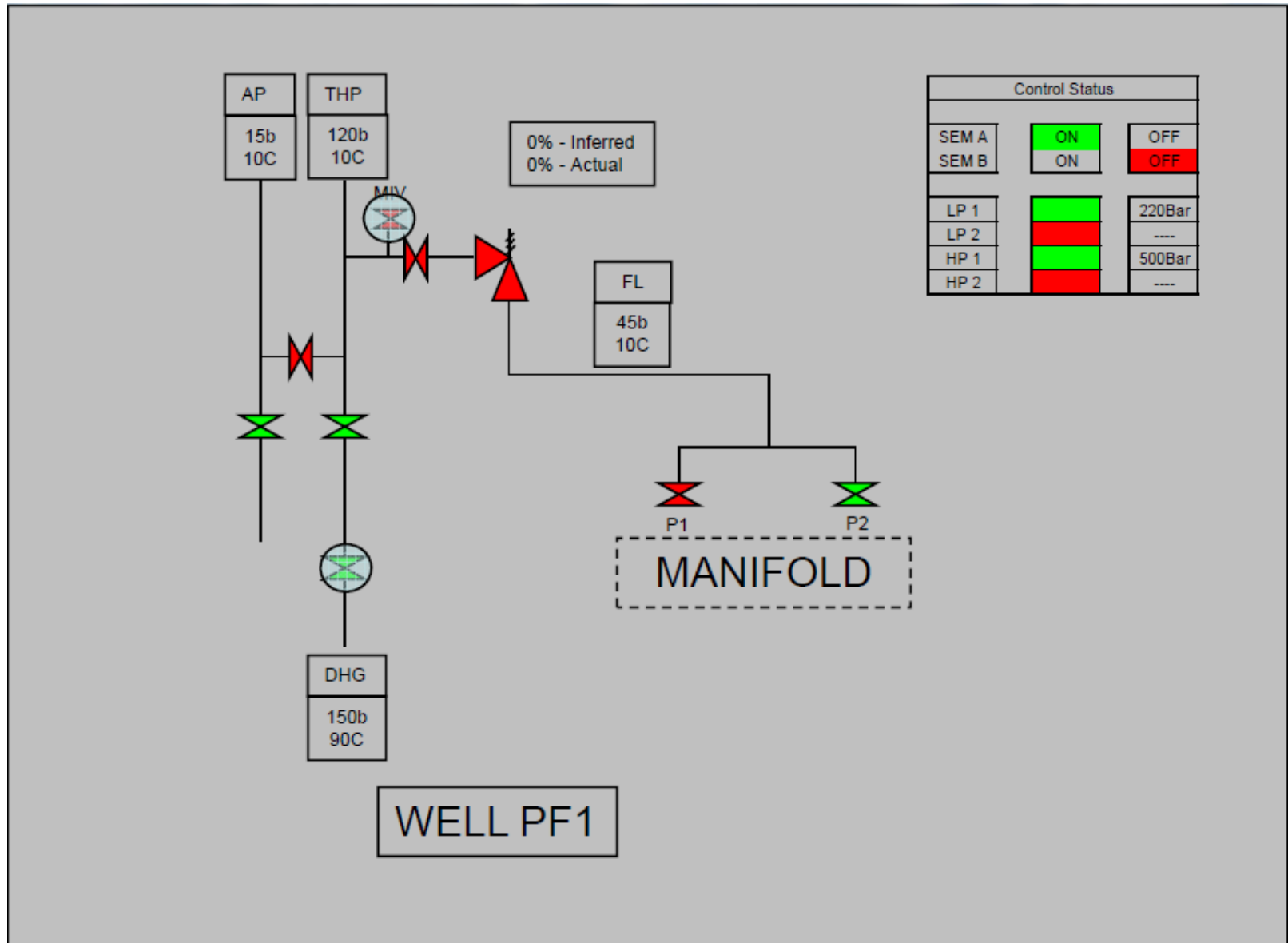

Opening a well 4 – PWV open

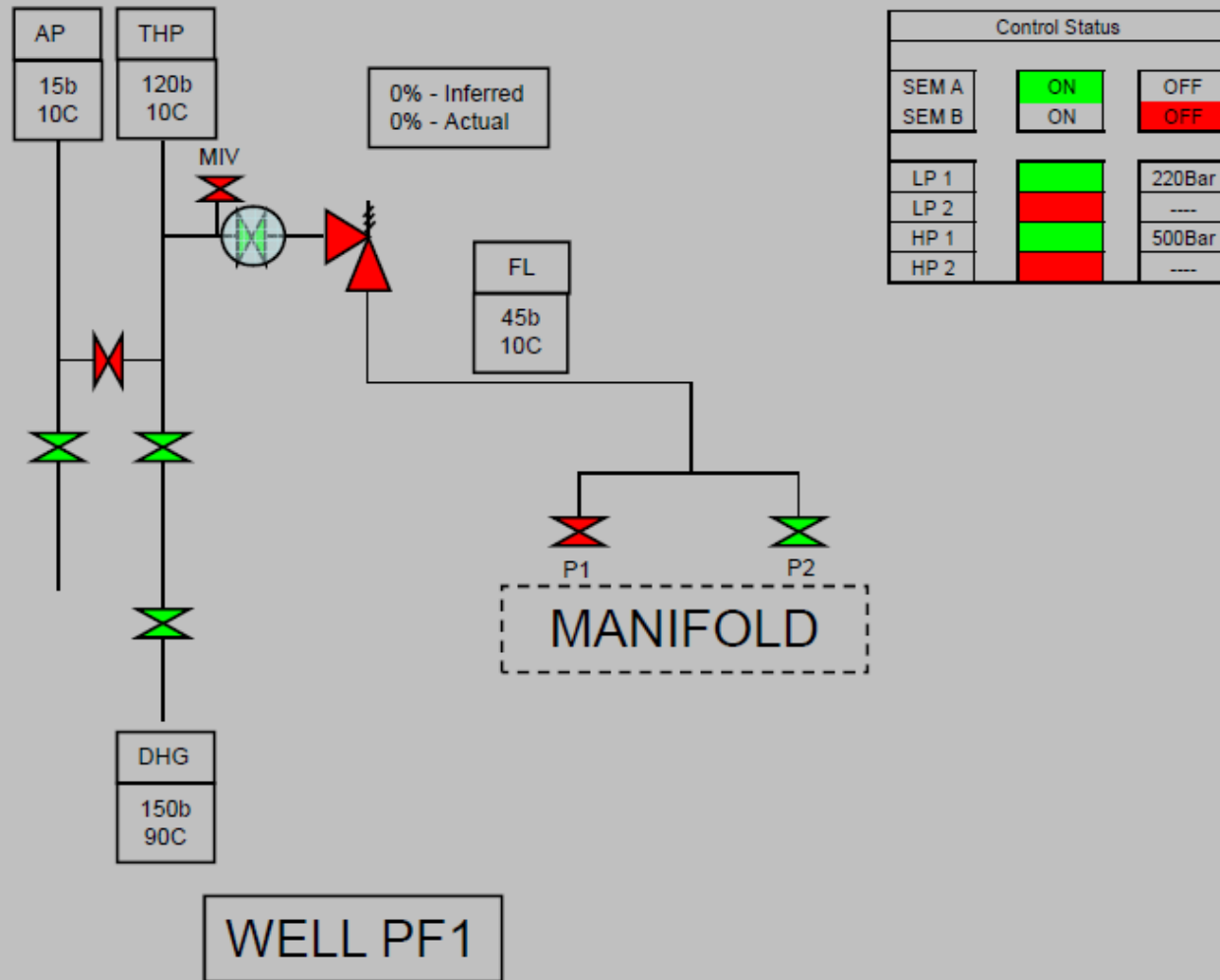

Operating the well valves

- Know what your shut in tubing head pressure is? If you don't know, ask the reservoir guys, if they don't know, fire them.
- Always have the choke valve closed prior to opening the tree valves
- Always minimize the differential pressure across your tree valves (500 kPa is a good rule of thumb to follow)
- It may not always be possible to get to this pressure, but minimize it as much as possible
- Always open 1 subsea valve at a time – the hydraulic system may not be able to cope with multiple valve openings. This creates low pressure in the hydraulic system. The control system interprets this as a loss of hydraulics = ESD
- Once all the tree valves are open, prior to opening the choke, check the routing valves on the manifold are open, allowing a flow to topsides.

Valve hydraulic graph

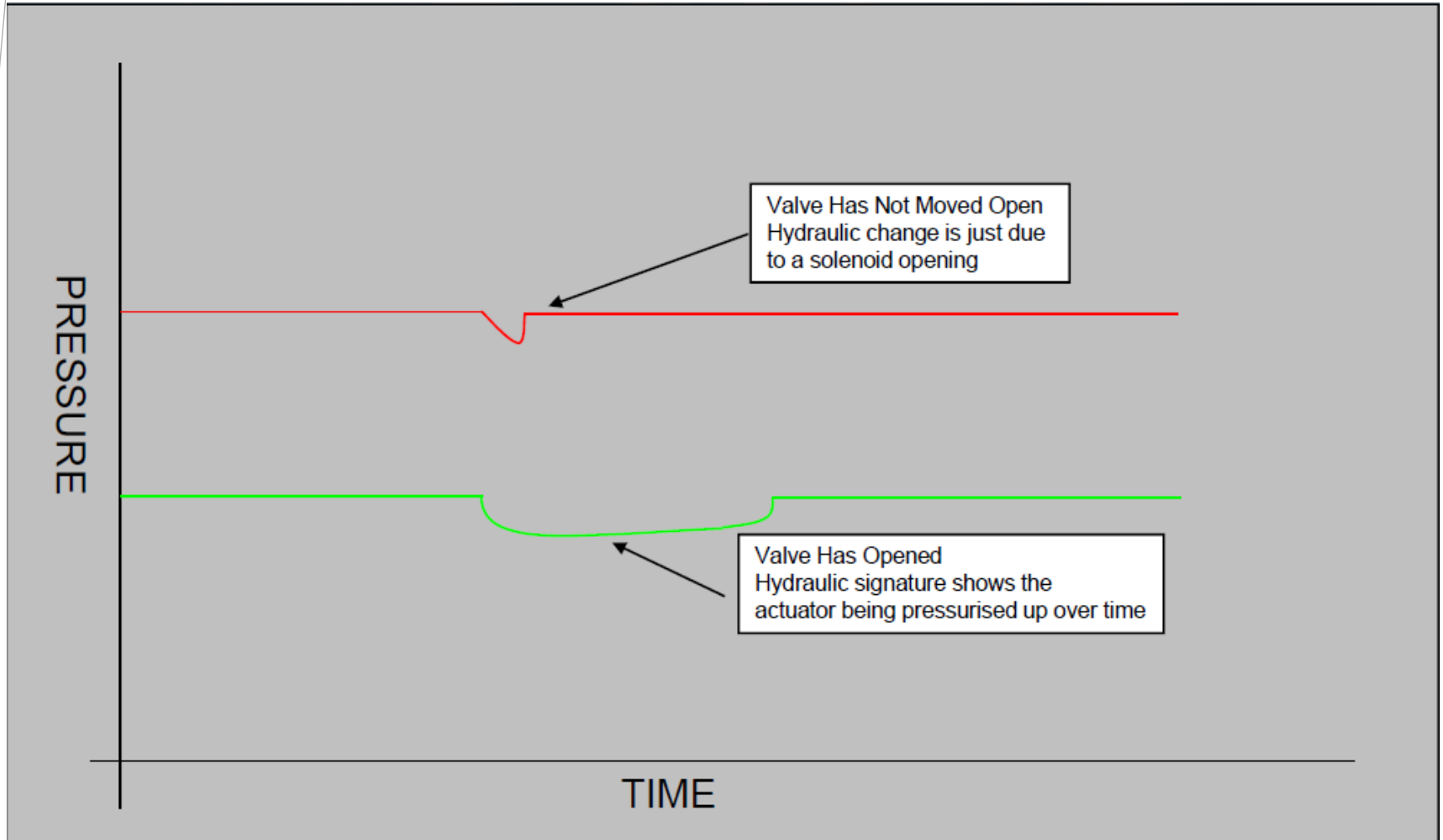

Opening a well 5 – ready to open choke

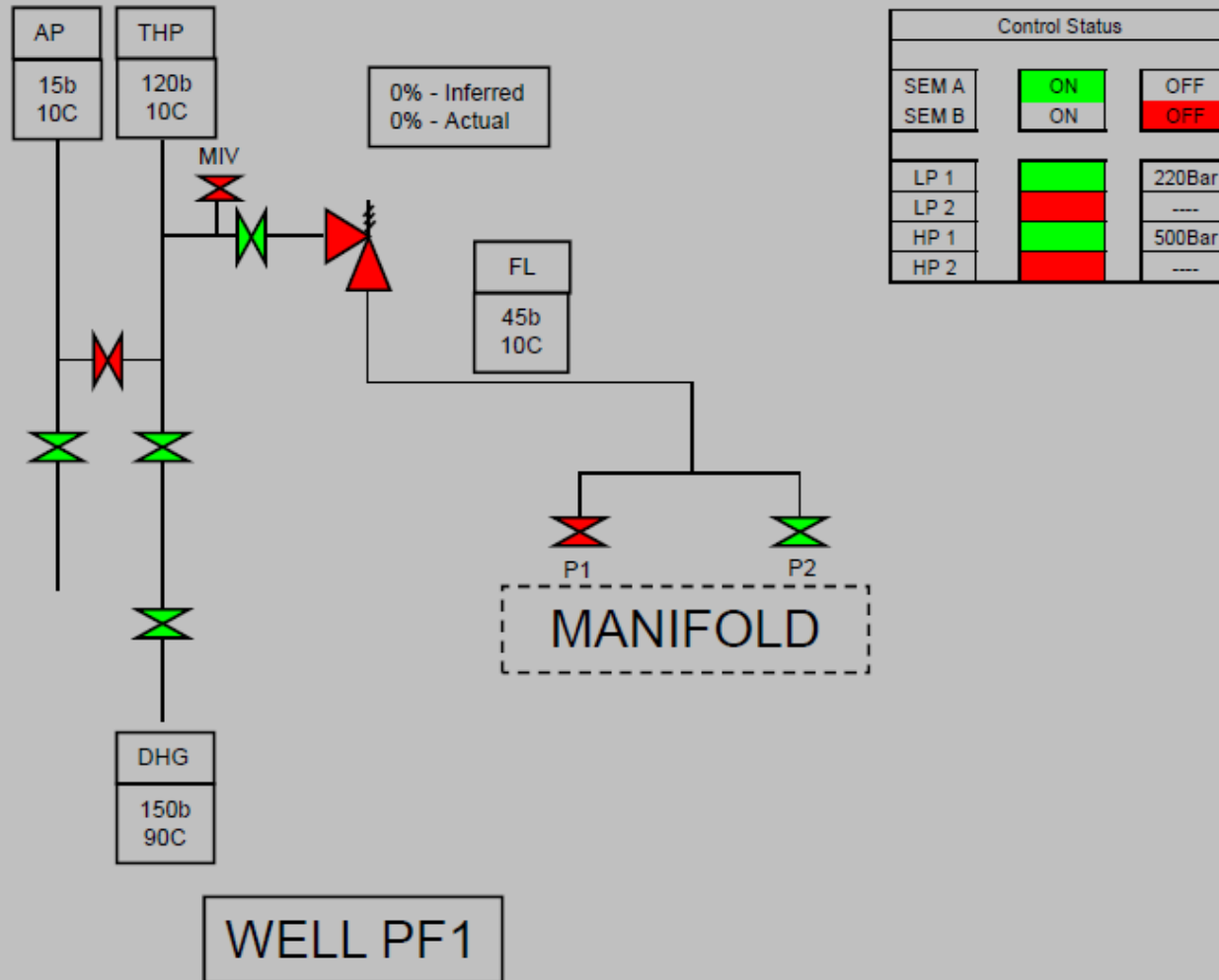

Operating the choke – what to monitor for

- Once you are sure all the hydraulic valves from the reservoir through to the topsides are open. Slowly open the choke
- Most subsea chokes are “step” actuator chokes. This basically means the control module for the well sends a hydraulic pulse to the choke, which steps it open. Most are 120 step chokes.
- When the choke is opening watch upstream and downstream temperature and pressures. They should change over time when the hot reservoir fluid/gases reach the tree
- If there is no change something is wrong. 99% of the time, it is because a valve isn't opened.
- If you are unsure to why the well is not flowing, close the choke and seek advice. Never open a tree valve which will put full reservoir flow & pressure into the system with an open choke.
- Typically it costs 30 MM USD to fix the valve or choke.

Opening the choke 1 – 16%

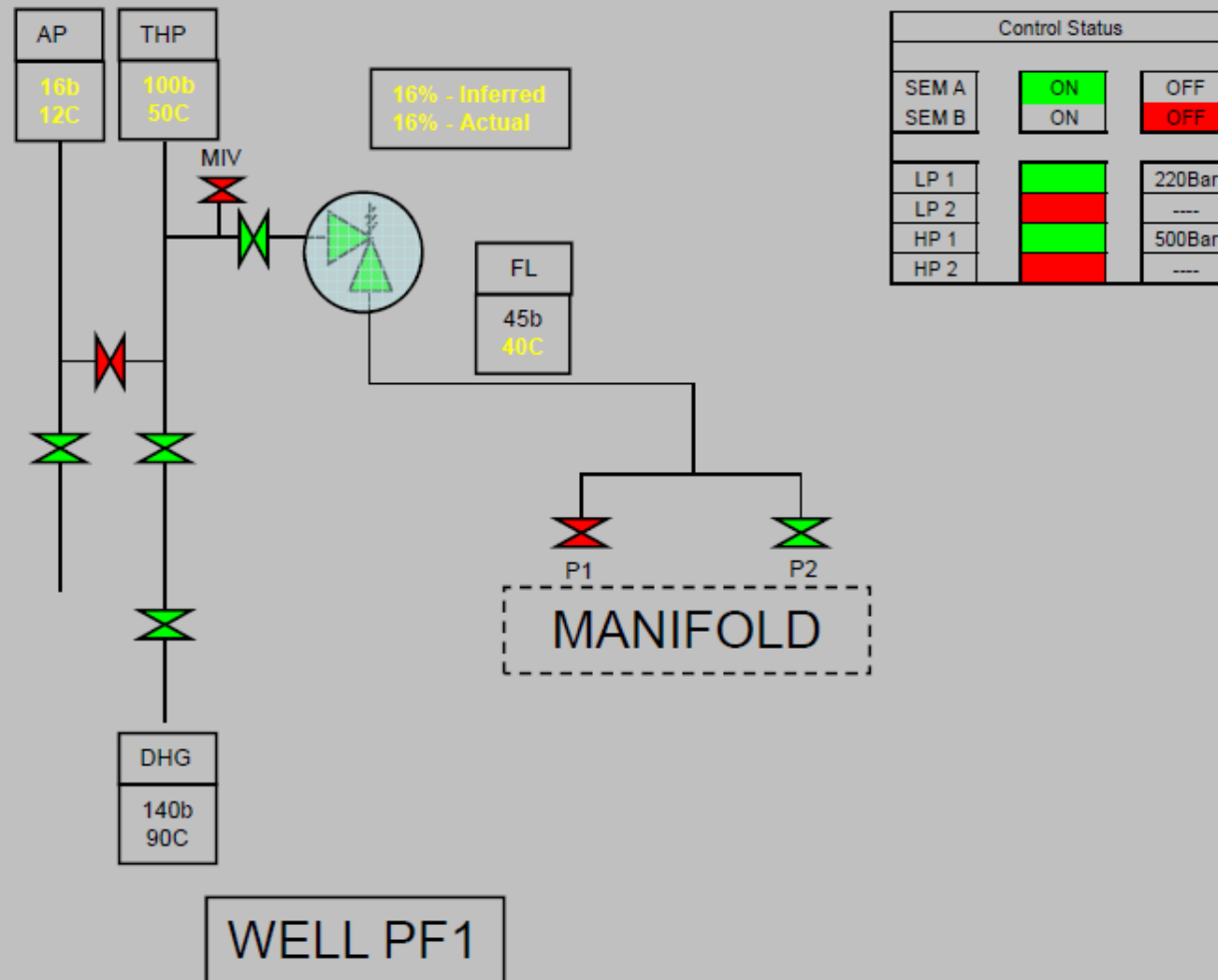

Opening the choke 2 – 50%

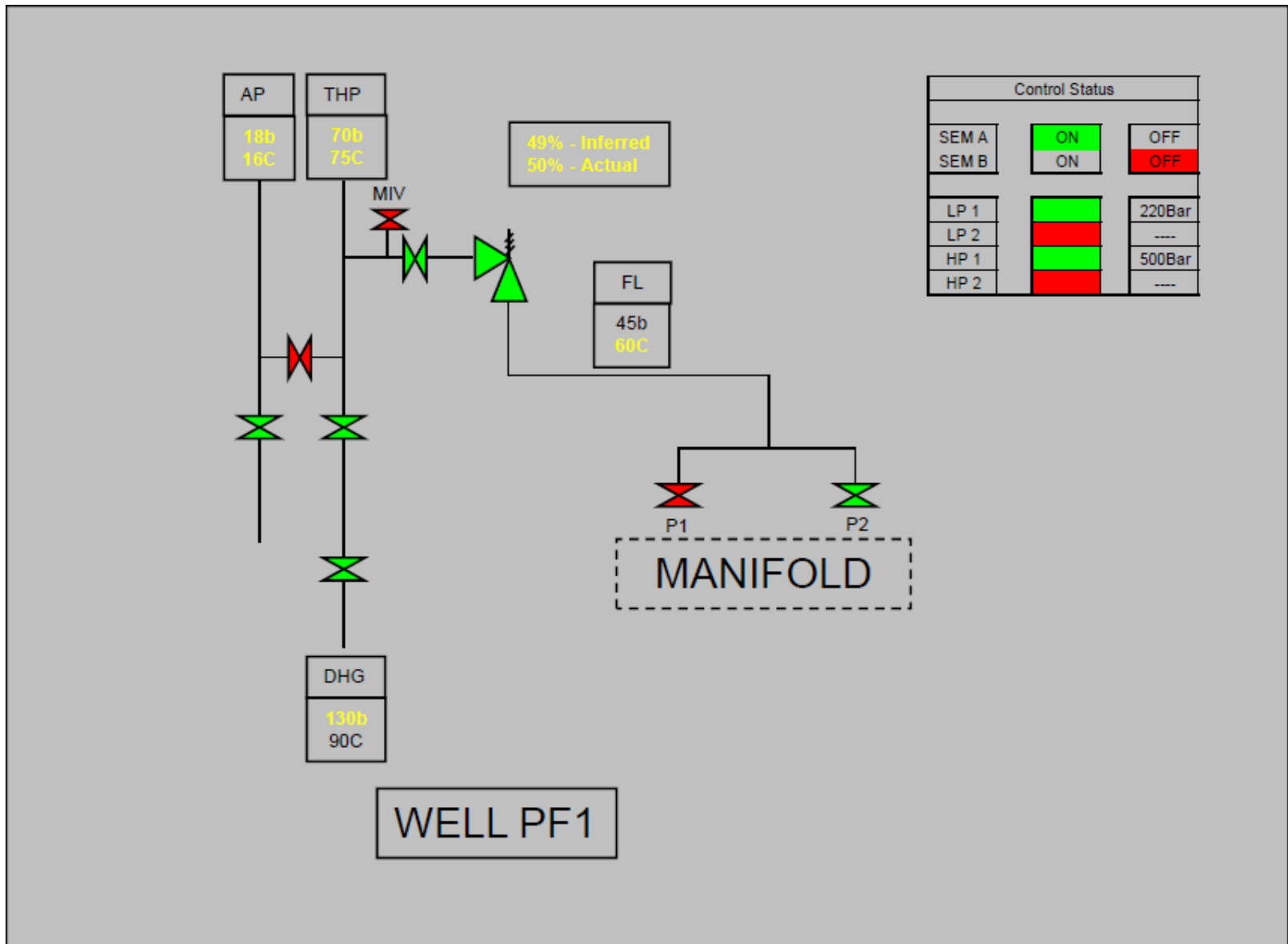

Choke hydraulic signals

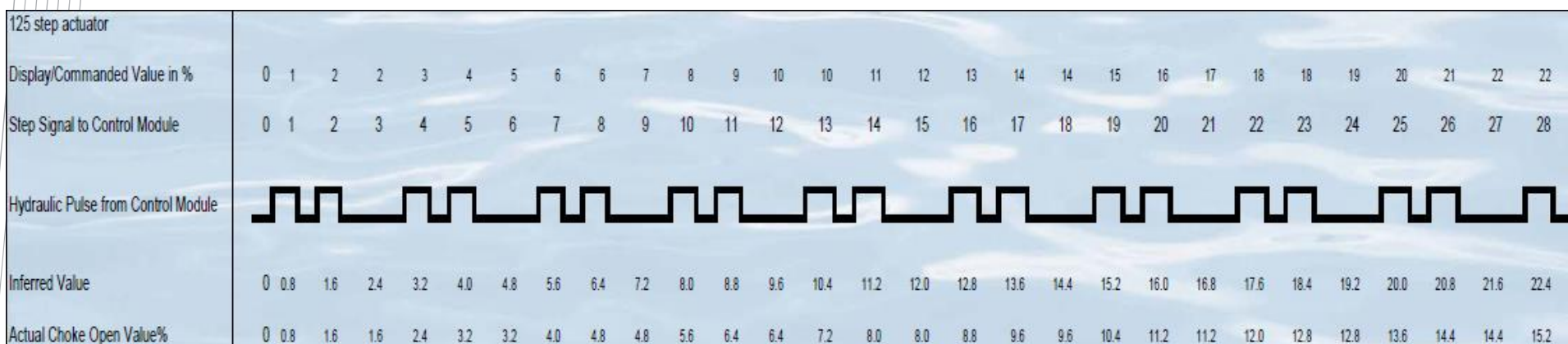
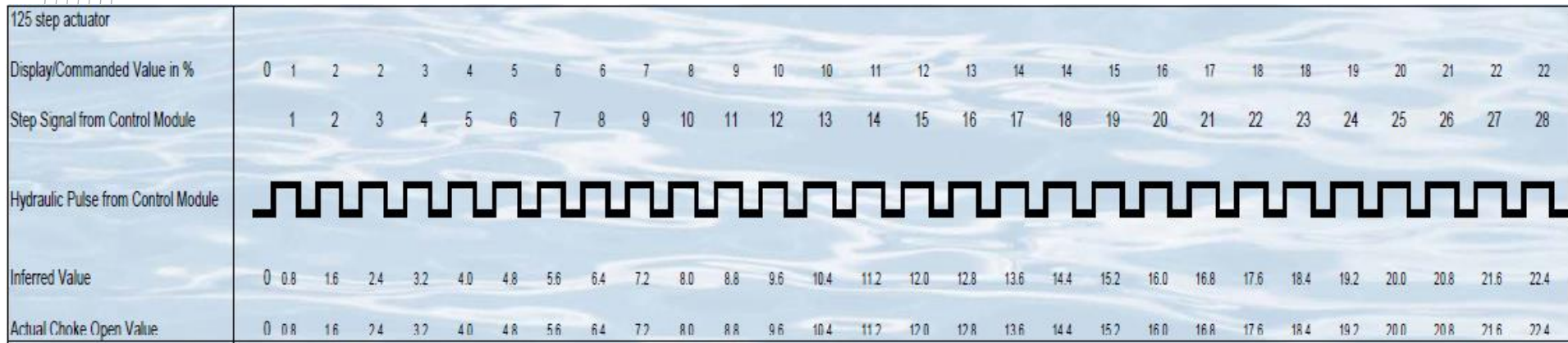

Closing in the well 1 – 50%

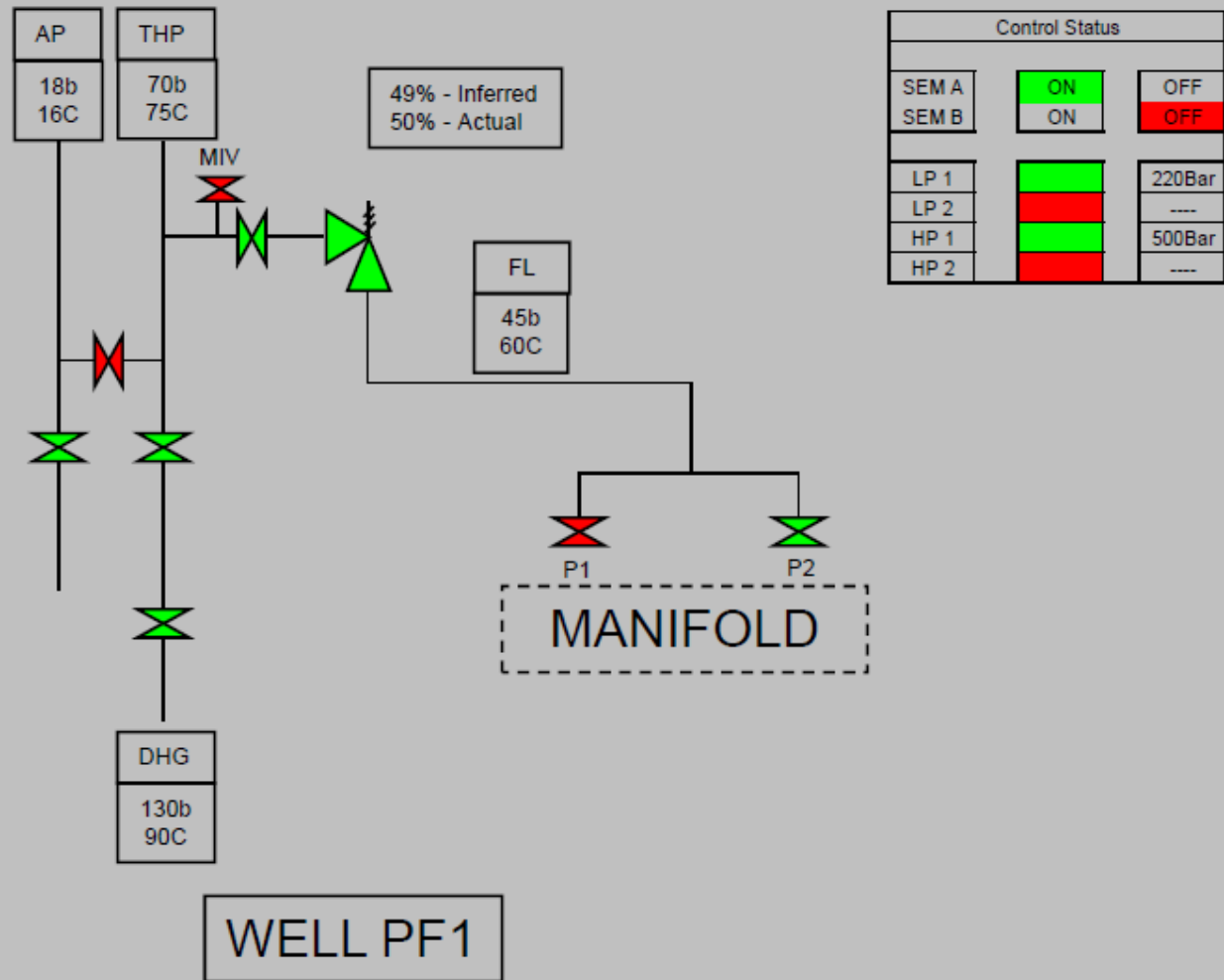

Closing in the well 2 – 25%

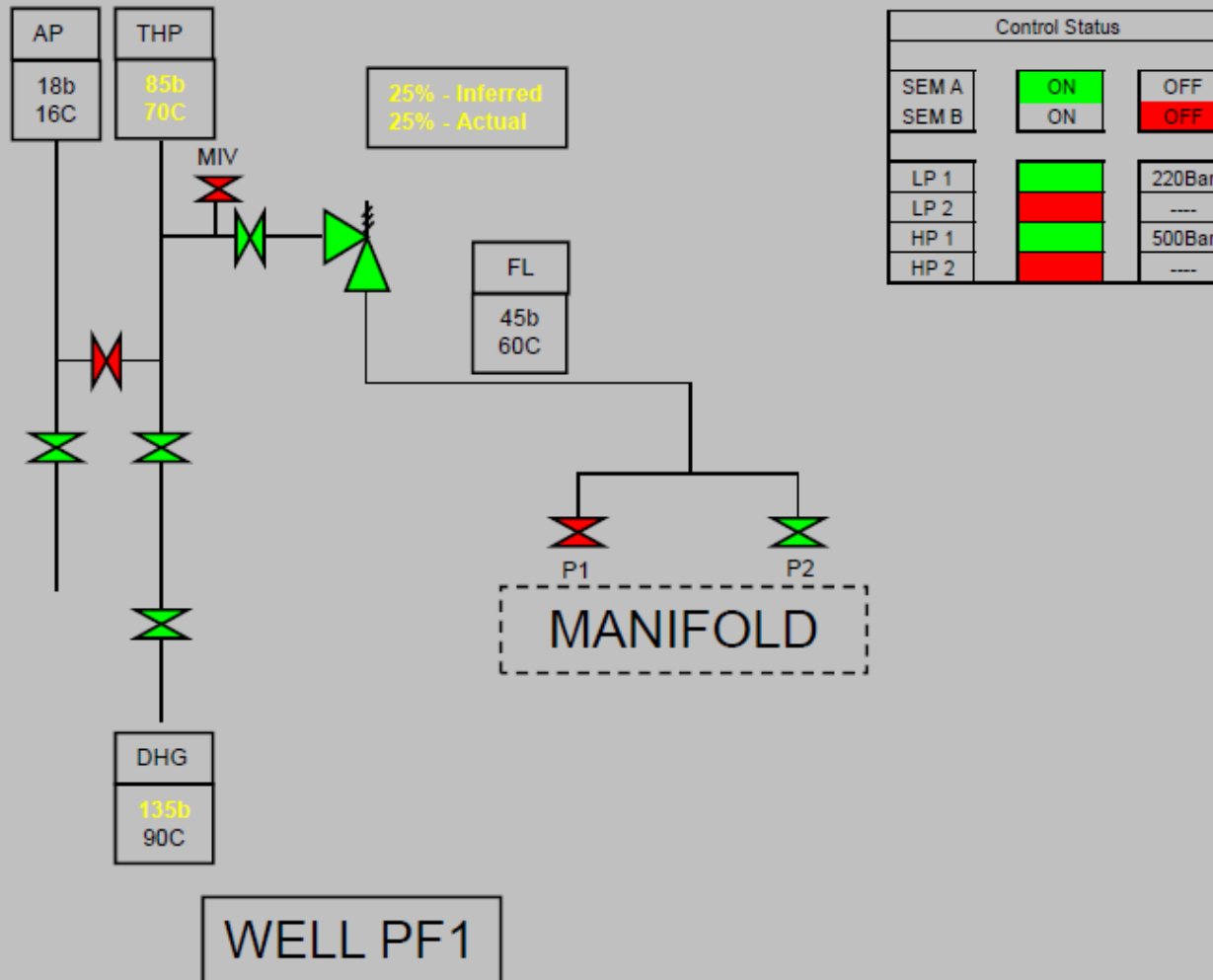

Closing in the well 3 – 16%

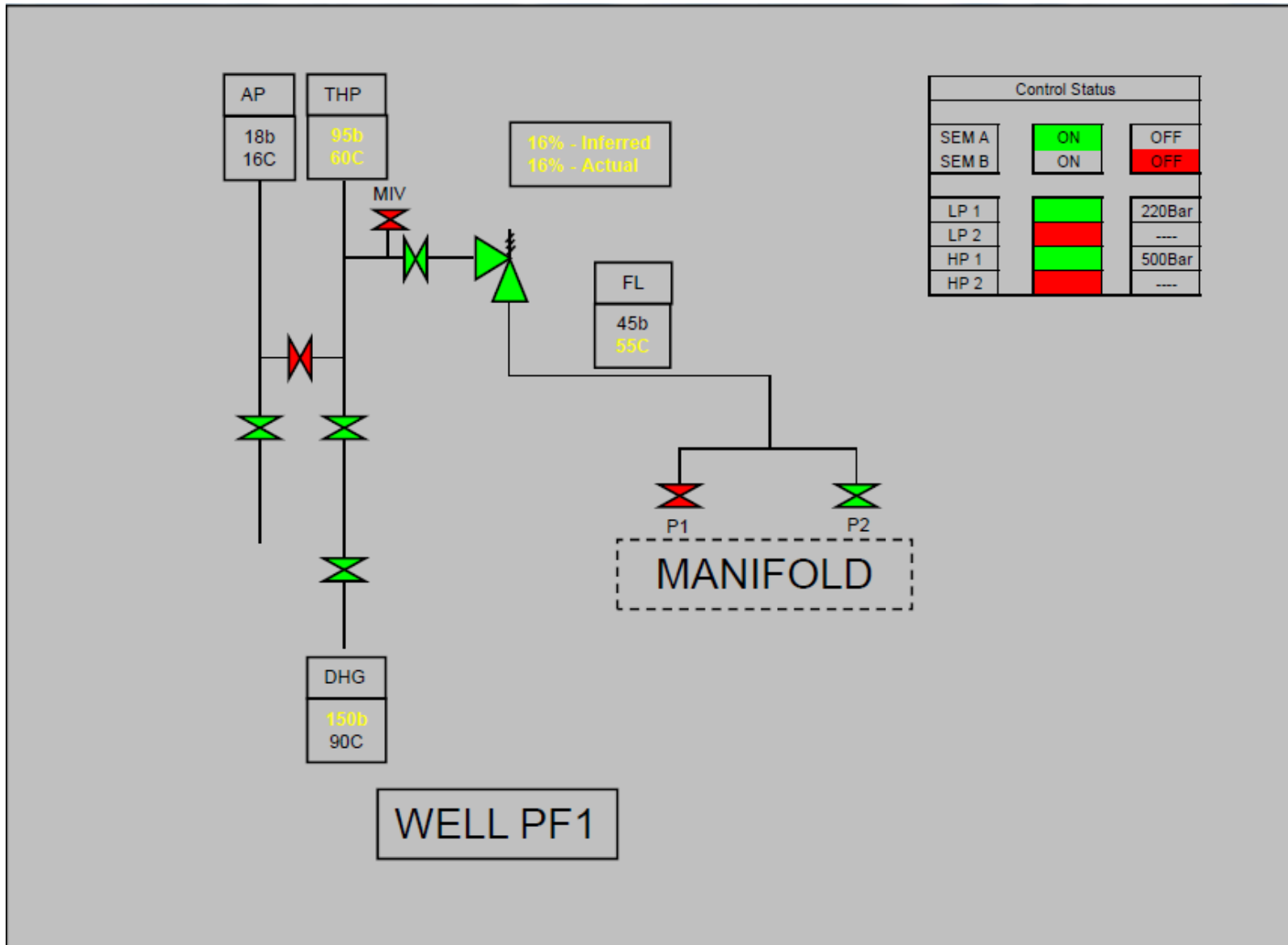

Closing in the well 4 – Shut-in

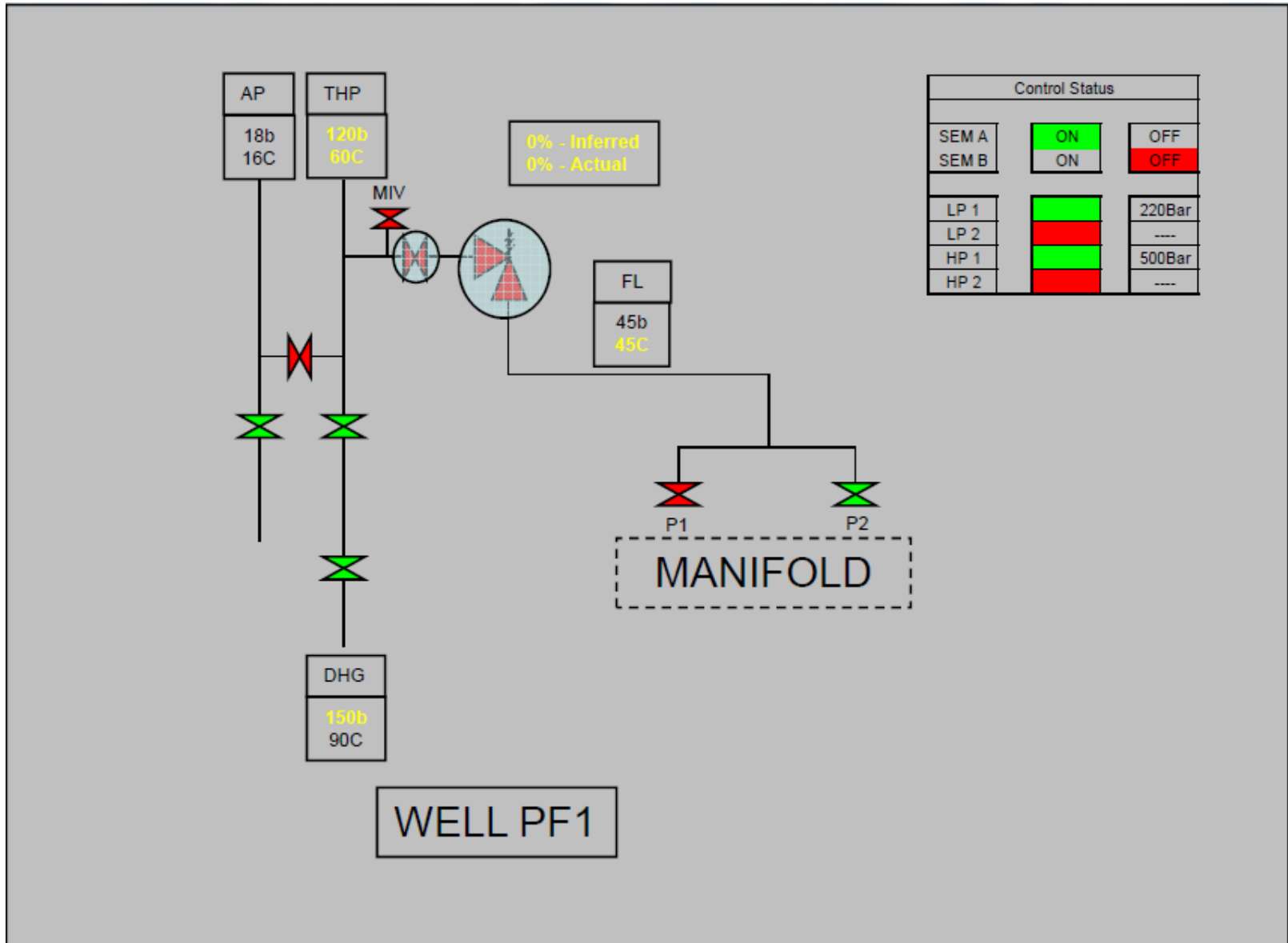

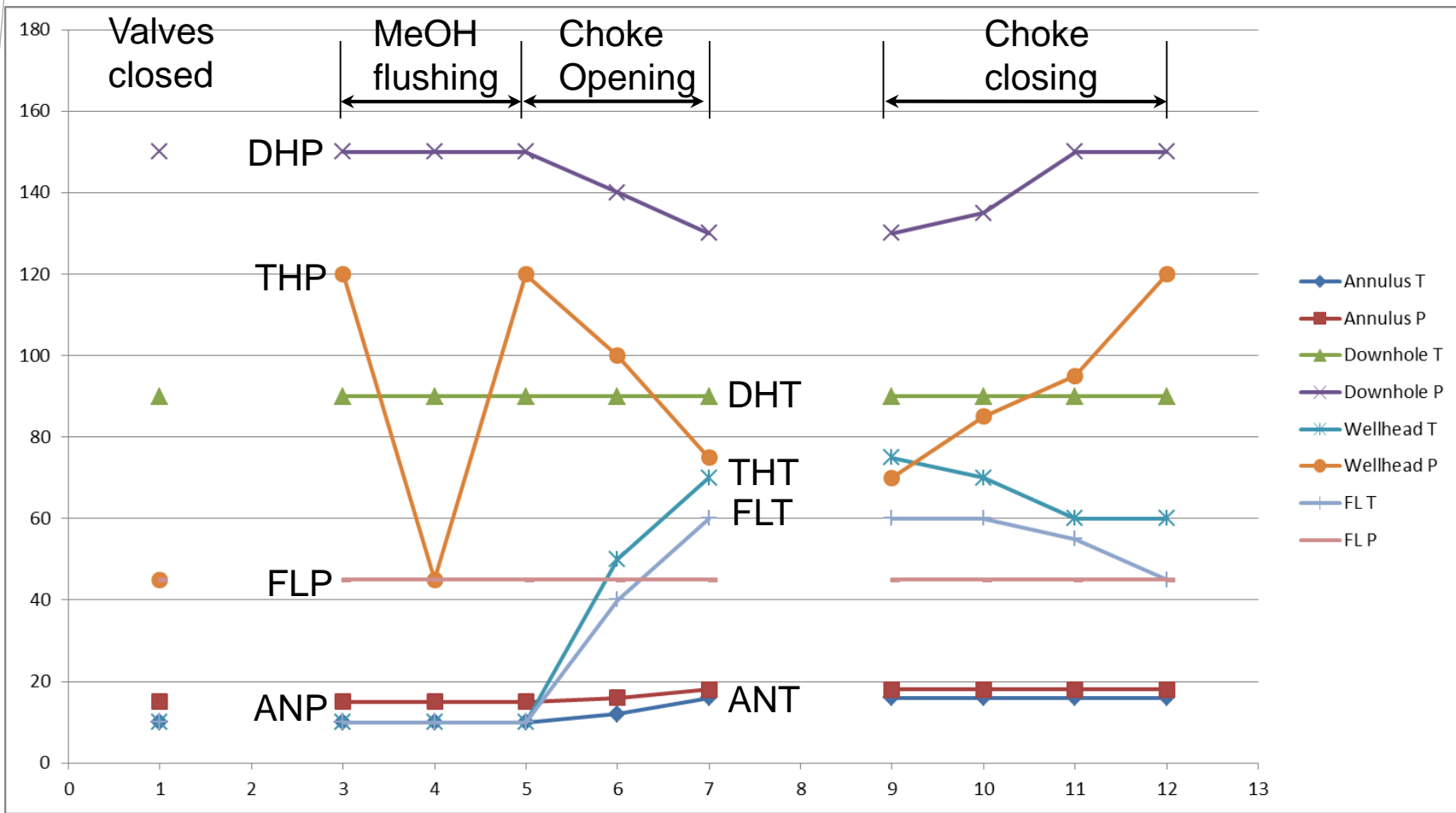

MIV MIV AMV 16% 50% 50% 25% 16% Shut-in
 AMV AMV PMV
 PMV SSV
 PWV

ESD shutdowns

- When an Emergency Shutdown occurs the well is put into a “safe” mode where all the hydraulic valves on the tree are shut.
- ESD 0 positions

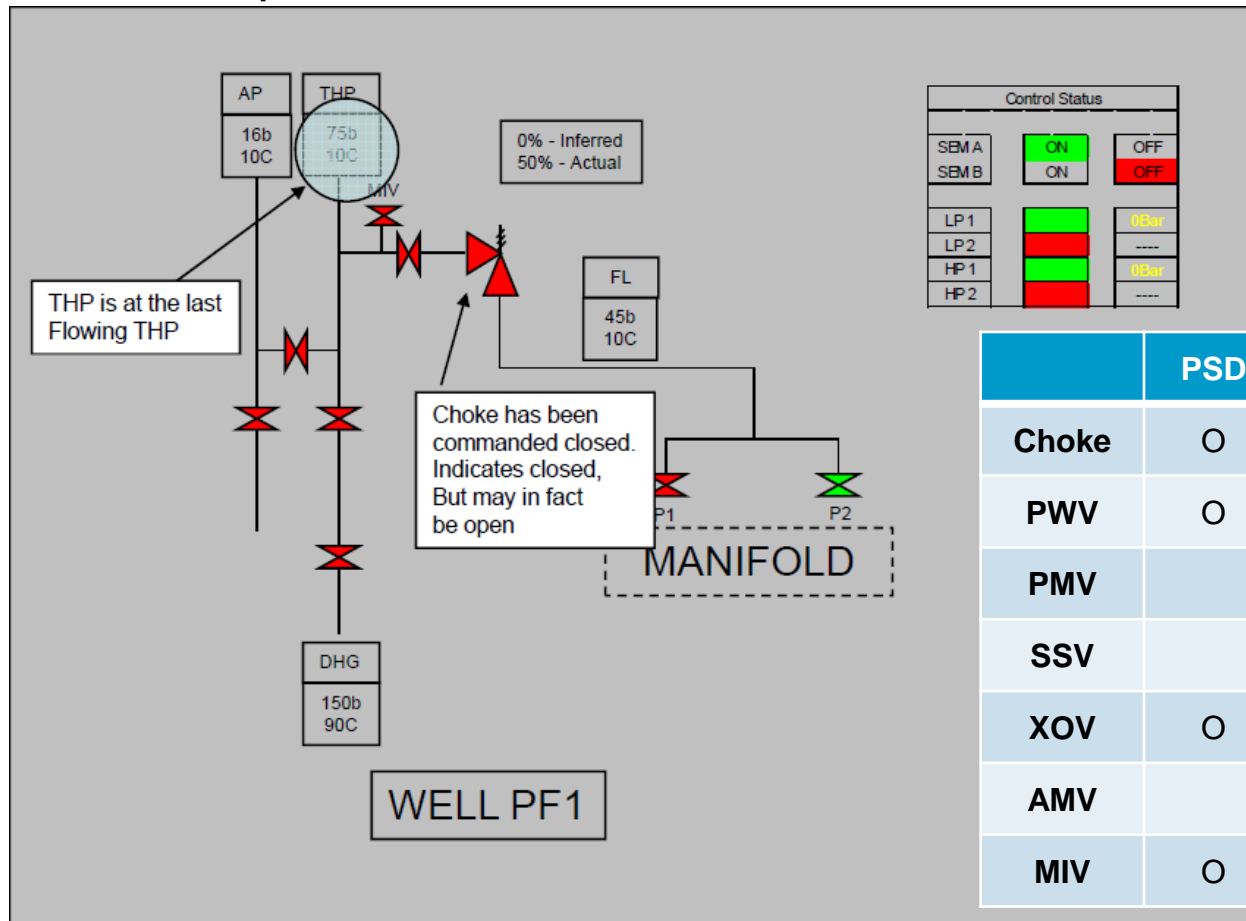

	PSD	ESD1	ESD0
Choke	○	○	○
PWV	○	○	○
PMV		○	○
SSV			○
XOV	○	○	○
AMV			○
MIV	○	○	○

General information

- It takes time to recover from a shutdown, well bean ups are not necessarily quick, take your time. Open the choke in small steps to prevent choke slippage.
- Watch your annulus pressure when you are beaning up, there are many cases of overpressurization due to temperature increases. Failed annulus = failed well = \$ MM
- Quick changes subsea mean process upsets topsides, usually 1 – 3 hrs after the change. Be prepared.
- During steady-state, there is unlikely to be any problems subsea, however it always good practice to log each wells pressures and temperatures every shift. You can usually see small changes and prevent upsets happening.

Operators can influence the design

- Ensure compatibility of process and shutdown logic between subsea and host systems.
- Minimize movements of subsea chokes.
- Ensure that the down hole safety valves only close in the event of an ESD in order to reduce damage/wear due to unnecessary closures.
- Select an appropriate performance standard for subsea valve leakage based on need rather than prescriptive standard which may not be applicable.

Poor Operations

- Wells brought on too fast causing high level trips at topside separators.
- Back pressure in system not maintained during well start up causing low temperatures downstream of chokes (due to J-T effect) brittle fracture or hydrate formation
- Failure to treat injection water causing failure of injection pipeline.
 - de-oxygenation, biociding.
 - Failure to maintain hydraulic fluid cleanliness
 - Topped up with mineral oil or potable water
 - HPU filling introduces contaminants such as fibers
 - Filters not changed frequently enough
 - Opening subsea gate/ball valves under high DP rather than equalizing pressure

What could go wrong?

- Failed Tree gauge fitting caused by opening the well on the wing valve, with the Choke fully open.
: EROSION.

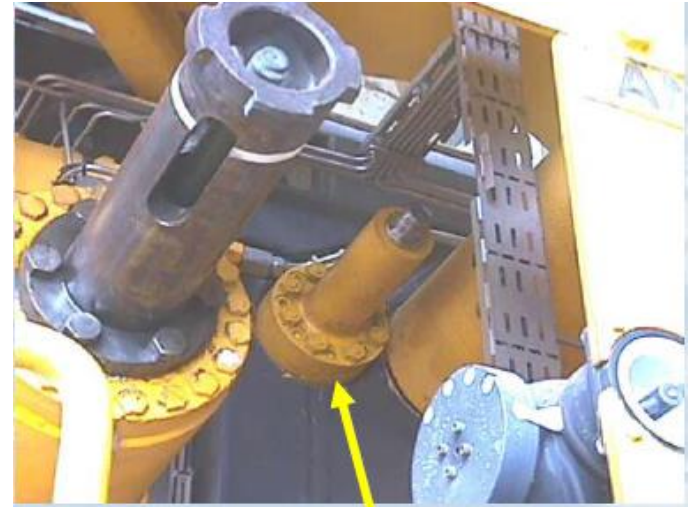

- Open gate valves against high differential pressure



Subsea leak

- ROV mounted floodlights showing fluid leakage - Visible spectrum

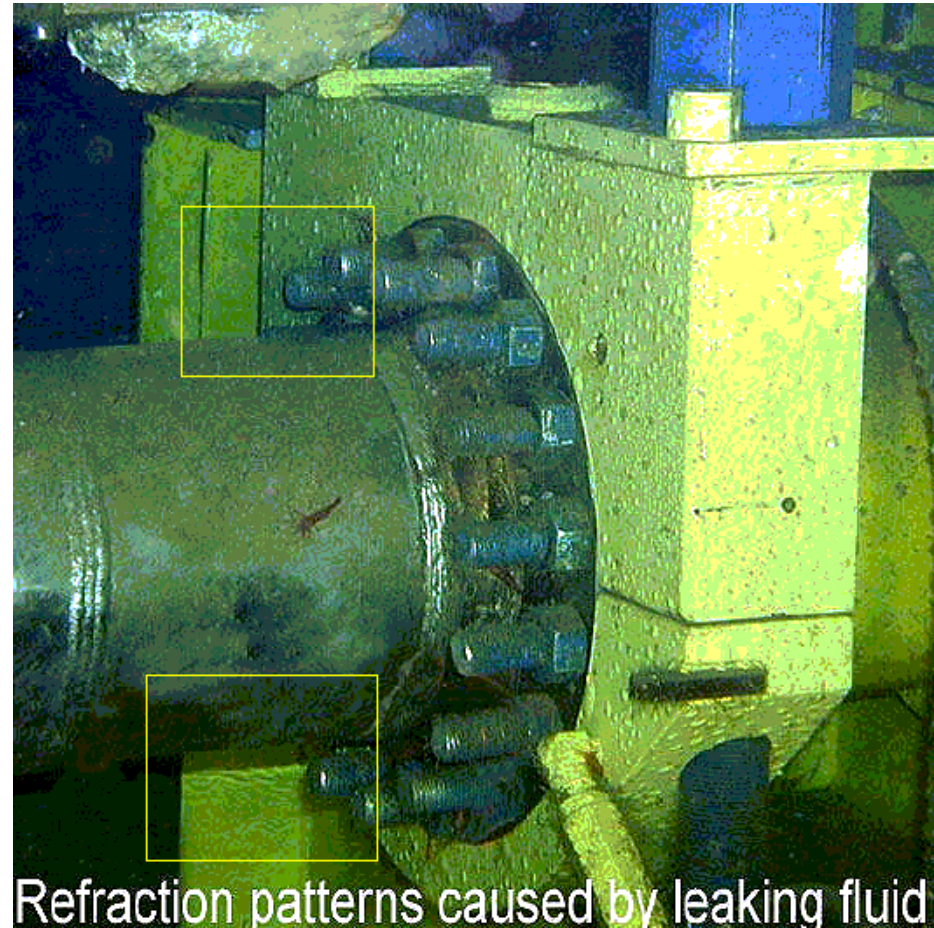

Refraction patterns caused by leaking fluid

Contact: Yutaek Seo

Email: Yutaek.Seo@snu.ac.kr

Thank you