

B-spline curve

CAD Lab.

Properties of B-spline curves

- ▶ **B-spline curve:**
 - ▶ Degree of curve is independent of number of control points
- ▶ **Bezier curve: global modification**
 - ▶ Modification of any one control point changes the curve shape everywhere
 - ▶ All the blending functions have non-zero value in the whole interval $0 \leq u \leq 1$

Bezier curve: global modification

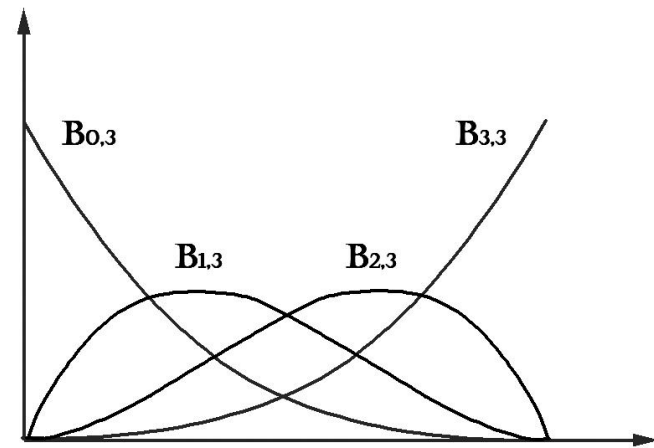
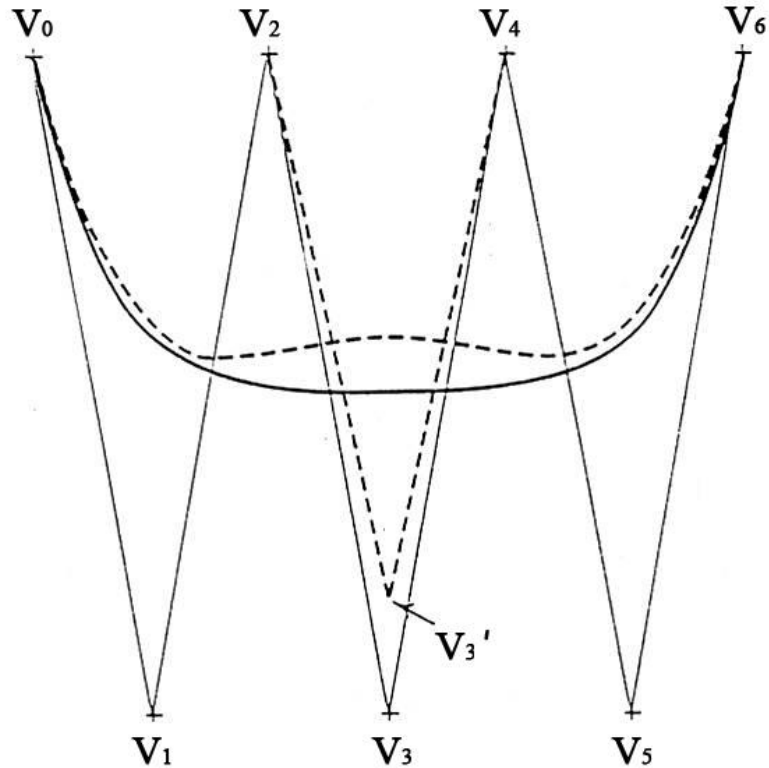

Bezier curve of degree 3

Desired Blending Function

Consider degree 1 blending functions, and $n=4$

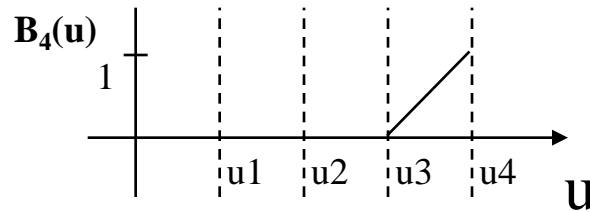
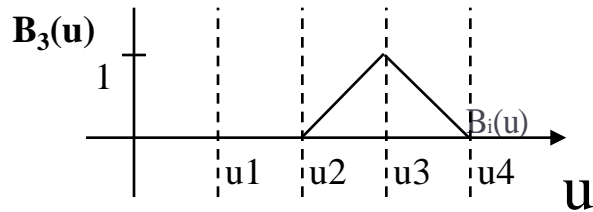
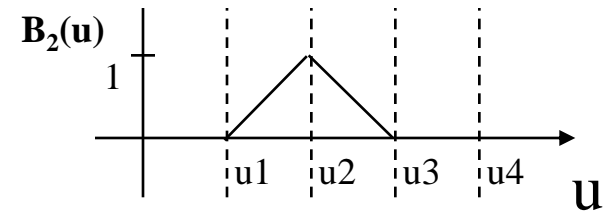
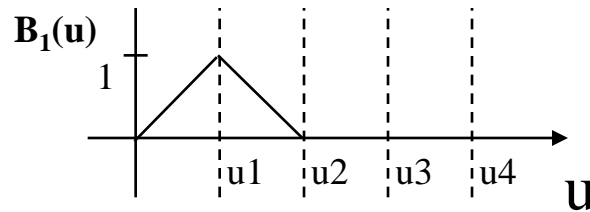
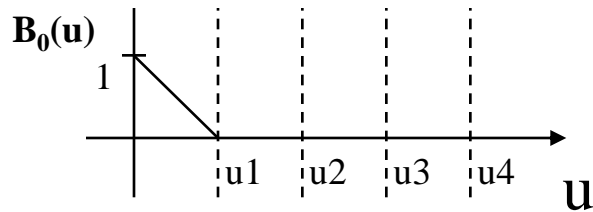

$$\mathbf{P}(u) = \sum_{i=0}^n \mathbf{P}_i \mathbf{B}_i(u)$$

P_0	has an effect only for	$0 \leq u \leq u_1$
P_1	has an effect only for	$0 \leq u \leq u_2$
P_2	has an effect only for	$u_1 \leq u \leq u_3$
P_3	has an effect only for	$u_2 \leq u \leq u_4$
P_4	has an effect only for	$u_3 \leq u \leq u_4$

Resulting Curve

For $0 \leq u \leq u_1$ $\mathbf{P}(u) = \mathbf{P}_0 B_0(u) + \mathbf{P}_1 B_1(u) = \mathbf{P}_0(1-u) + \mathbf{P}_1 u$

... straight line from P_0 to P_1

For $u_1 \leq u \leq u_2$ $\mathbf{P}(u) = \mathbf{P}_1 B_1(u) + \mathbf{P}_2 B_2(u) = \mathbf{P}_1(2-u) + \mathbf{P}_2(u-1)$

... straight line from P_1 to P_2

Similarly

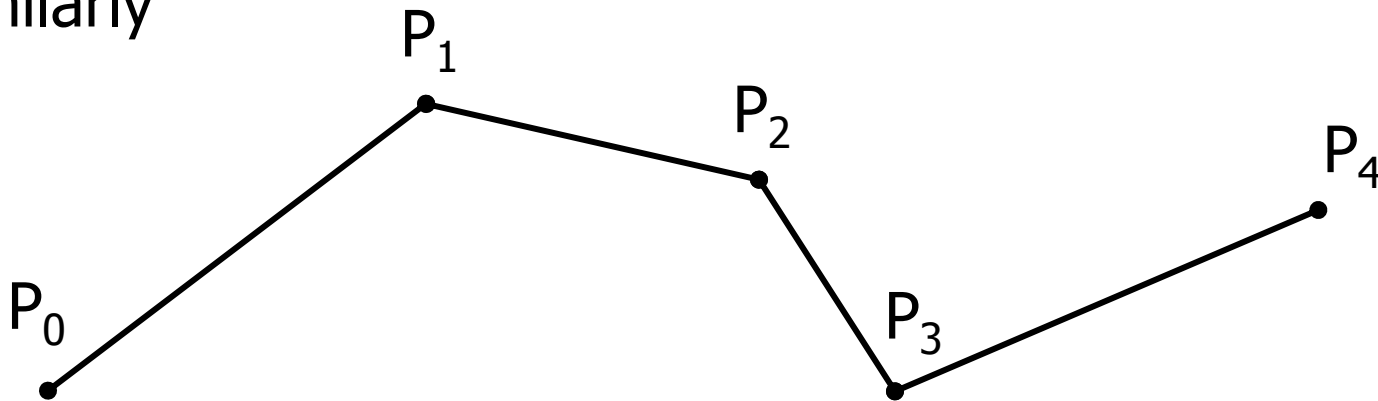

Blending Function

Consider degree 2 blending functions, and $n=5$

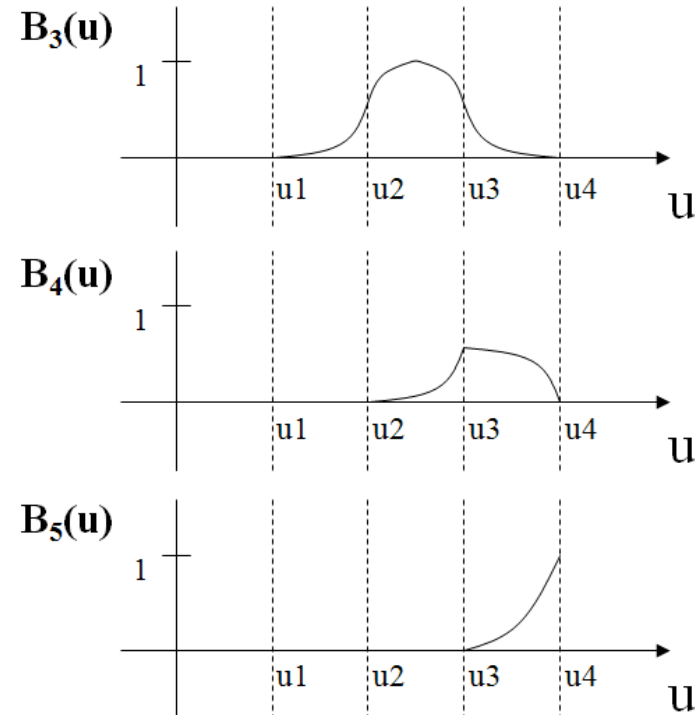
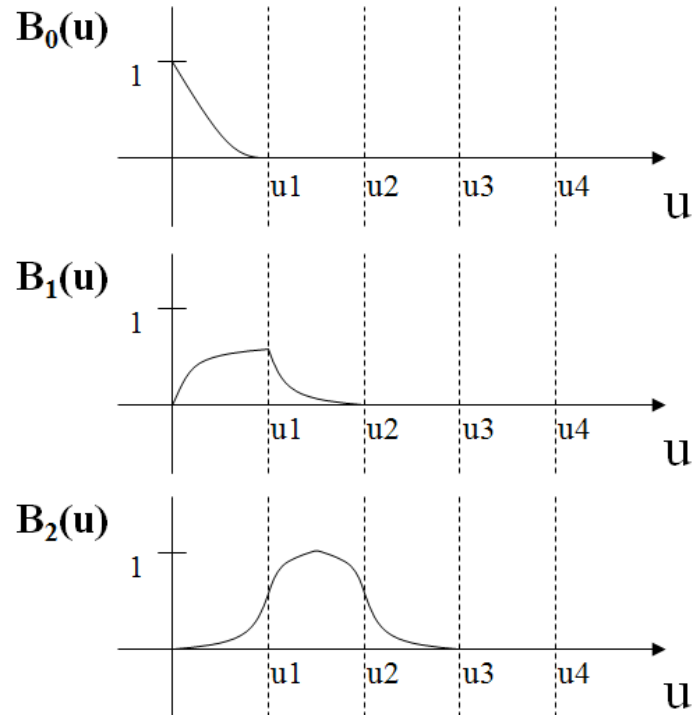

P_0 has an effect only for $0 \leq u \leq u_1$
 P_2 has an effect only for $0 \leq u \leq u_3$
 P_4 has an effect only for $u_2 \leq u \leq u_4$

P_1 has an effect only for $0 \leq u \leq u_2$
 P_3 has an effect only for $u_1 \leq u \leq u_4$
 P_5 has an effect only for $u_3 \leq u \leq u_4$

Resulting Curve

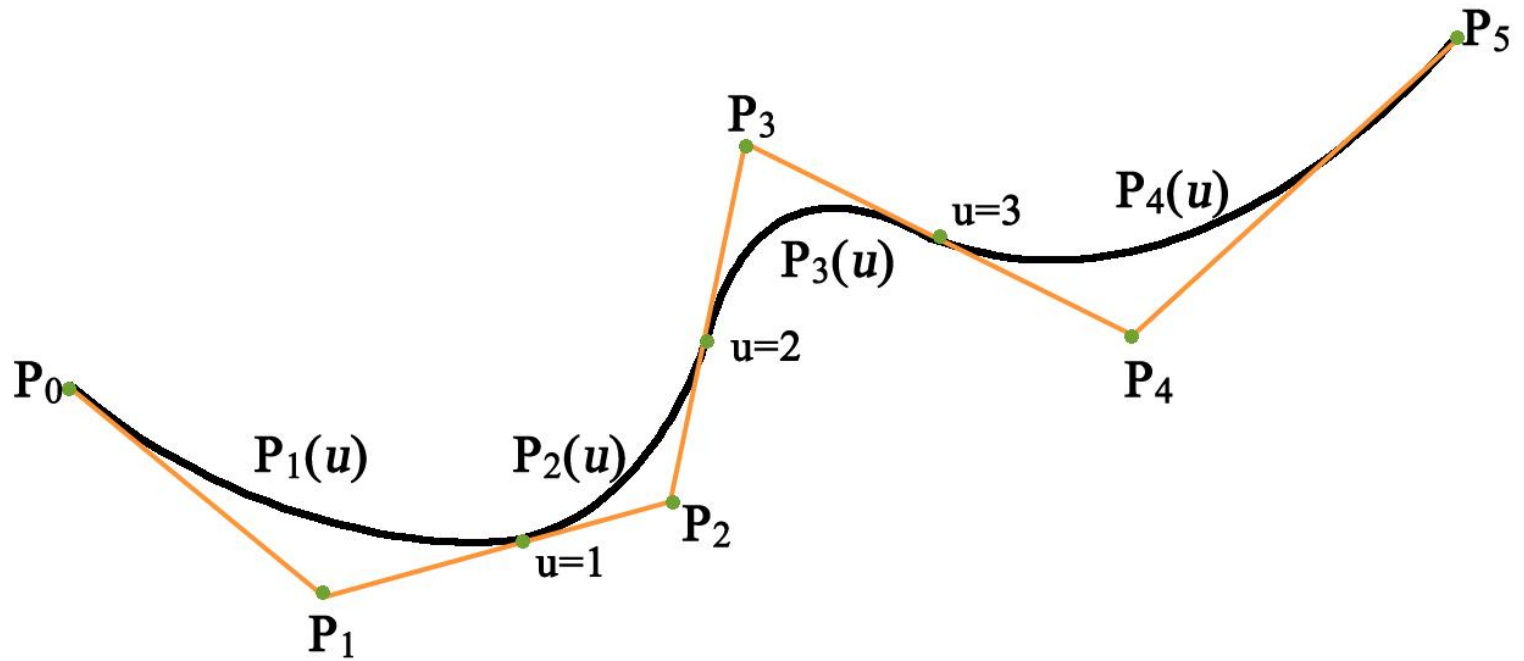

B-spline curve equation – cont'

$$\mathbf{P}(u) = \sum_{i=0}^n \mathbf{P}_i N_{i,k}(u) \quad t_{k-1} \leq u \leq t_{n+1} \quad (\text{a})$$

$$N_{i,k}(u) = \frac{(u - t_i) N_{i,k-1}(u)}{t_{i+k-1} - t_i} + \frac{(t_{i+k} - u) N_{i+1,k-1}(u)}{t_{i+k} - t_{i+1}} \quad \left(\begin{array}{c} 0 \\ 0 \end{array} = 0 \right) \quad (\text{b})$$

$$N_{i,1}(u) = \begin{cases} 1 & t_i \leq u < t_{i+1} \\ 0 & \text{otherwise} \end{cases} \rightarrow \text{At any value of } u, \text{ there should} \\ \text{be only one non-zero } N_{i,1}(u) \quad (\text{c})$$

- ▶ $N_{i,k}$: degree (k-1) of u, k : order (independent of number of control points n)
- ▶ t_i : knot values, boundary of non-zero range of each blending function
- ▶ t_0 (for $i=0$) to t_{n+k} (for $i=n$) are needed ($n+k+1$ values)

B-spline curve equation – cont'

- ▶ Only the differences in t_i ($i=0, \dots, n+k$) is important in (b)
- ▶ Can be shifted as a whole, parameter range should be shifted together
- ▶ A portion of B-spline curve is affected by a limited number of control points
- ▶ For u in $[t_l, t_{l+1}]$
 - ▶ Control points associated with blending functions that are non-zero in $[t_l, t_{l+1}]$ have effect
 - ▶ $N_{l,1}(u)$ is nonzero in $[t_l, t_{l+1}]$ among $N_{i,1}(u)$
 - ▶ Substitute $N_{l,1}(u)$ into the right-hand side of (b)
 - ▶ $N_{l,2}(u), N_{l-1,2}(u)$ can be non-zero
 - ▶ Apply recursively
 - ▶ From $N_{l,2}(u), N_{l,3}(u)$ and $N_{l-1,3}(u)$ can be non-zero
 - ▶ From $N_{l-1,2}(u), N_{l-1,3}(u)$ and $N_{l-2,3}(u)$ can be non-zero

B-spline curve equation – cont'

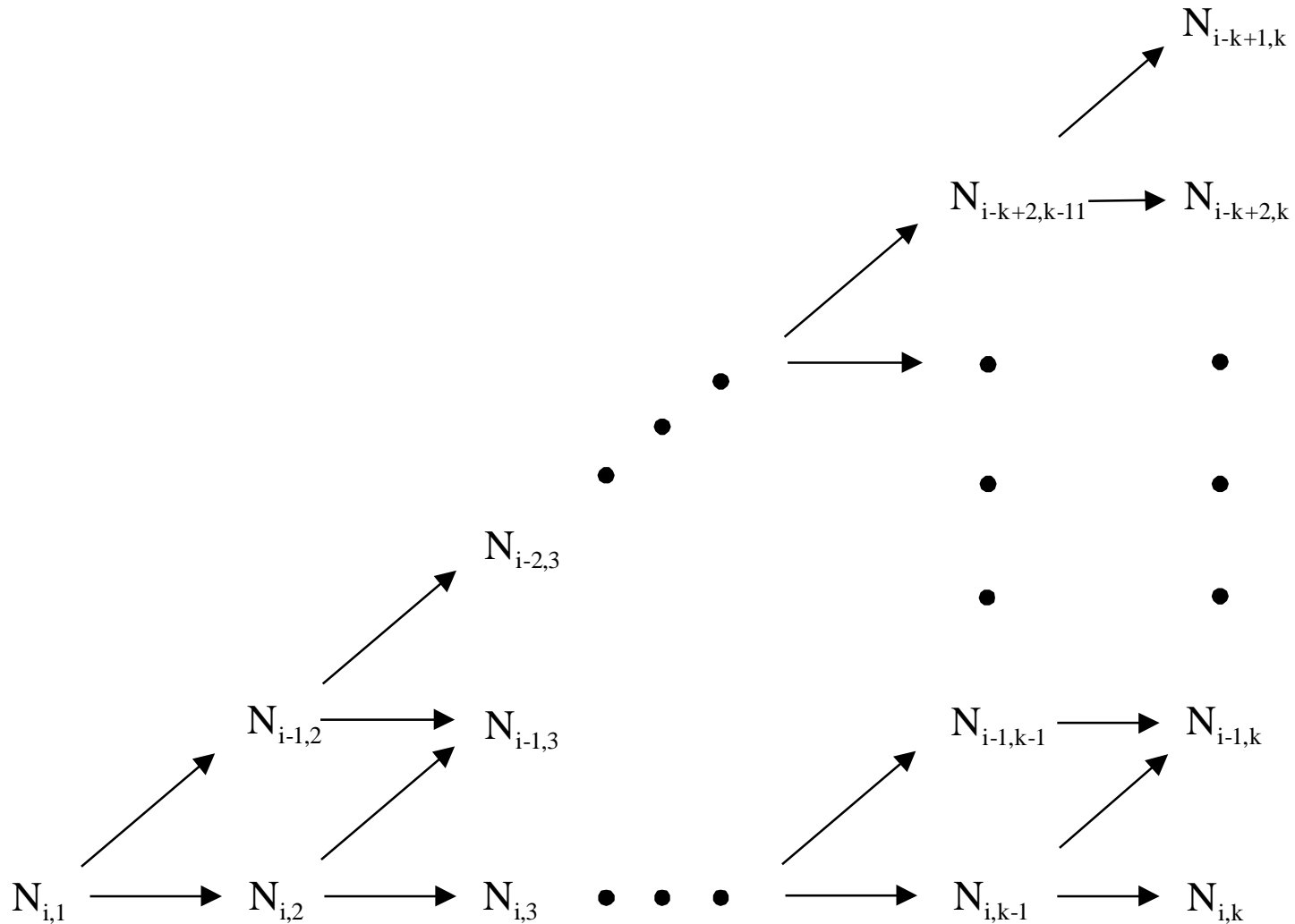

B-spline curve equation – cont'

- ▶ Control points that have influence in the region $[t_i, t_{i+1}]$ are
 - ▶ $P_{i-k+1}, P_{i-k+2}, \dots, P_i$ k control points
 - ▶ Control points modify: [example](#)

B-spline curve - Knot

- ▶ **Knot:** t_0, t_1, \dots, t_{n+k}
 - ▶ parameter range is determined by knots
 - ▶ Periodic knots
 - ▶ $t_i = i - k \quad 0 \leq i \leq n+k$
 - ▶ Non-periodic knots

$$t_i = \begin{cases} 0 & 0 \leq i < k & \text{duplicates } k \text{ times} \\ i - k + 1 & k \leq i \leq n \\ n - k + 2 & n < i \leq n + k & \text{duplicates } k \text{ times} \end{cases} \quad (d)$$

Periodic vs. Non-periodic

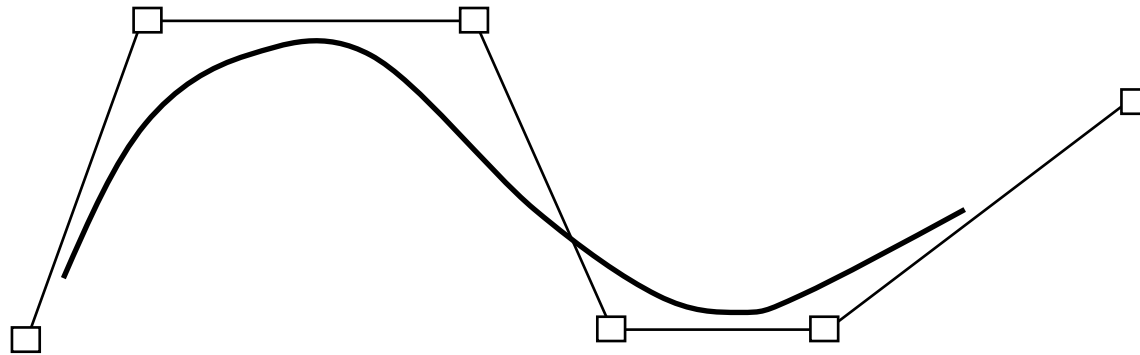

Periodic knot

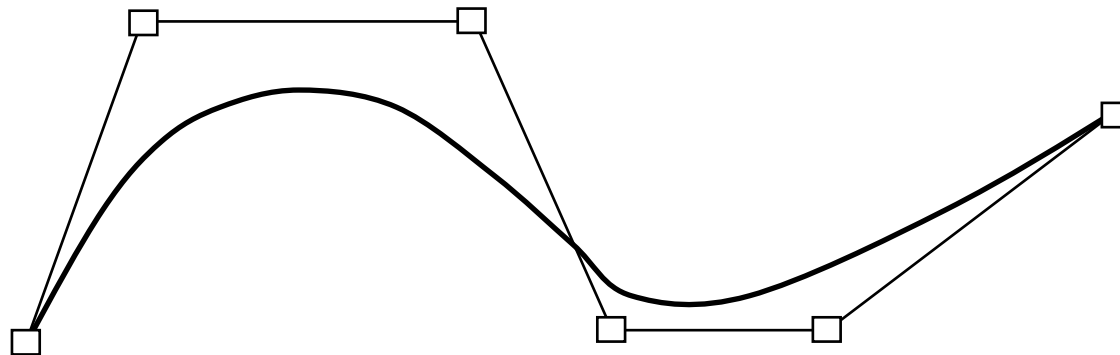

Non-periodic knot

B-spline curve - Knot

- ▶ By duplicating knot k times at the ends
 - ▶ Curve passes through first control point and last control point
- ▶ Periodic knot
 - ▶ First control point and last control point do not pass through curve as other control points
 - ▶ non-periodic knots are used in most CAD systems
- ▶ knot interval is uniform in (d)
 - ▶ uniform B-spline (vs. non-uniform B-spline)
- ▶ During manipulation of curve shape, knots are added or removed
 - ▶ non-uniform knot \rightarrow non-uniform B-spline curve

Example program

- ▶ Knot Insertion
 - ▶ Example

Expansion of curve equation

▶ Ex)

- ▶ $K=3, P_0, P_1, P_2$ non-periodic uniform B-spline

$$t_0=0, t_1=0, t_2=0, t_3=1, t_4=1, t_5=1$$

$$0 \leq u \leq 1$$

↑

↑

(= t_2)

(= t_3)

Expansion of curve equation – cont'

$$N_{0,1}(u) = \begin{cases} 1 & t_0 \leq u \leq t_1 \\ 0 & \text{otherwise} \end{cases} \quad (u = 0)$$

$$N_{1,1}(u) = \begin{cases} 1 & t_1 \leq u \leq t_2 \\ 0 & \text{otherwise} \end{cases} \quad (u = 0)$$

$$N_{2,1}(u) = \begin{cases} 1 & t_2 \leq u \leq t_3 \\ 0 & \text{otherwise} \end{cases} \quad (0 \leq u \leq 1)$$

$$N_{3,1}(u) = \begin{cases} 1 & t_3 \leq u \leq t_4 \\ 0 & \text{otherwise} \end{cases} \quad (u = 1)$$

$$N_{4,1}(u) = \begin{cases} 1 & t_4 \leq u \leq t_5 \\ 0 & \text{otherwise} \end{cases} \quad (u = 1)$$

Expansion of curve equation – cont'

- ▶ At $u=0$, select $N_{2,1}(u)$ to be non-zero among $N_{0,1}(0)$, $N_{1,1}(0)$, $N_{2,1}(0)$
- ▶ Selection of any one is O.K.
- ▶ At $u=1$, select $N_{2,1}(u)$ similarly
- ▶ Only $N_{2,1}(u)$ needs to be considered among blending functions of order 1

Expansion of curve equation – cont'

$$N_{1,2}(\mathbf{u}) = \frac{(\mathbf{u} - t_1)N_{1,1}}{t_2 - t_1} + \frac{(t_3 - \mathbf{u})N_{2,1}}{t_3 - t_2} = \frac{(1 - \mathbf{u})N_{2,1}}{1} = (1 - \mathbf{u})$$

$$N_{2,2}(\mathbf{u}) = \frac{(\mathbf{u} - t_2)N_{2,1}}{t_3 - t_2} + \frac{(t_4 - \mathbf{u})N_{3,1}}{t_4 - t_3} = \frac{\mathbf{u}N_{2,1}}{1} = \mathbf{u}$$

$$N_{0,3}(\mathbf{u}) = \frac{(\mathbf{u} - t_0)N_{0,2}}{t_2 - t_0} + \frac{(t_3 - \mathbf{u})N_{1,2}}{t_3 - t_1} = \frac{(1 - \mathbf{u})N_{1,2}}{1} = (1 - \mathbf{u})^2$$

$$N_{1,3}(\mathbf{u}) = \frac{(\mathbf{u} - t_1)N_{1,2}}{t_3 - t_1} + \frac{(t_4 - \mathbf{u})N_{2,2}}{t_4 - t_2} = \mathbf{u}(1 - \mathbf{u}) + (1 - \mathbf{u})\mathbf{u} = 2\mathbf{u}(1 - \mathbf{u})$$

$$N_{2,3}(\mathbf{u}) = \frac{(\mathbf{u} - t_2)N_{2,2}}{t_4 - t_2} + \frac{(t_5 - \mathbf{u})N_{3,2}}{t_5 - t_3} = \mathbf{u}^2$$

$$\therefore \mathbf{P}(\mathbf{u}) = (1 - \mathbf{u})^2 \mathbf{P}_0 + 2\mathbf{u}(1 - \mathbf{u})\mathbf{P}_1 + \mathbf{u}^2 \mathbf{P}_2$$

Expansion of curve equation – cont'

- ▶ Consider Bezier curve defined by P_0, P_1, P_2

$$\mathbf{P}(u) = \binom{2}{0} u^0 (1-u)^2 \mathbf{P}_0 + \binom{2}{1} u^1 (1-u)^1 \mathbf{P}_1 + \binom{2}{2} u^2 (1-u)^0 \mathbf{P}_2$$

- ▶ Non-periodic B-spline curve having k (order) control points ends in Bezier curve
- ▶ Bezier curve is a special case of B-spline curve

Example

► Ex)

$K=3$, $P_0, P_1, P_2, P_3, P_4, P_5$

$t_0=0, t_1=0, t_2=0, t_3=1, t_4=2, t_5=3, t_6=4, t_7=4, t_8=4$

$0 \leq u \leq 4$

$$N_{2,1}(u) = \begin{cases} 1 & 0 \leq u \leq 1 \\ 0 & \text{otherwise} \end{cases}$$

$$N_{3,1}(u) = \begin{cases} 1 & 1 \leq u \leq 2 \\ 0 & \text{otherwise} \end{cases}$$

$$N_{4,1}(u) = \begin{cases} 1 & 2 \leq u \leq 3 \\ 0 & \text{otherwise} \end{cases}$$

$$N_{5,1}(u) = \begin{cases} 1 & 3 \leq u \leq 4 \\ 0 & \text{otherwise} \end{cases}$$

Example – cont'

$$N_{1,2}(u) = \frac{(u - t_1)N_{1,1}}{t_2 - t_1} + \frac{(t_3 - u)N_{2,1}}{t_3 - t_2} = (1 - u)N_{2,1}$$

$$N_{2,2}(u) = \frac{(u - t_2)N_{2,1}}{t_3 - t_2} + \frac{(t_4 - u)N_{3,1}}{t_4 - t_3} = u N_{2,1} + (2 - u)N_{3,1}$$

$$N_{3,2}(u) = \frac{(u - t_3)N_{3,1}}{t_4 - t_3} + \frac{(t_5 - u)N_{4,1}}{t_5 - t_4} = (u - 1)N_{3,1} + (3 - u)N_{4,1}$$

$$N_{4,2}(u) = \frac{(u - t_4)N_{4,1}}{t_5 - t_4} + \frac{(t_6 - u)N_{5,1}}{t_6 - t_5} = (u - 2)N_{4,1} + (4 - u)N_{5,1}$$

$$N_{5,2}(u) = \frac{(u - t_5)N_{5,1}}{t_6 - t_5} + \frac{(t_7 - u)N_{6,1}}{t_7 - t_6} = (u - 3)N_{5,1}$$

Example – cont'

$$N_{0,3}(u) = \frac{(u-t_0)N_{0,2}}{t_2-t_0} + \frac{(t_3-u)N_{1,2}}{t_3-t_1} = (1-u)N_{1,2} = (1-u)^2 N_{2,1}$$

$$\begin{aligned} N_{1,3}(u) &= \frac{(u-t_1)N_{1,2}}{t_3-t_1} + \frac{(t_4-u)N_{2,2}}{t_4-t_2} = u N_{1,2} + \frac{2-u}{2} N_{2,2} \\ &= \left[u(1-u) + \frac{(2-u)u}{2} \right] N_{2,1} + \frac{(2-u)^2}{2} N_{3,1} \end{aligned}$$

$$\begin{aligned} N_{2,3}(u) &= \frac{(u-t_2)N_{2,2}}{t_4-t_2} + \frac{(t_5-u)N_{3,2}}{t_5-t_3} = \frac{u}{2} N_{2,2} + \frac{3-u}{2} N_{3,2} \\ &= \frac{u^2}{2} N_{2,1} + \left[\frac{u(2-u)}{2} + \frac{(3-u)(u-1)}{2} \right] N_{3,1} + \frac{(3-u)^2}{2} N_{4,1} \end{aligned}$$

$$\begin{aligned} N_{3,3}(u) &= \frac{(u-t_3)N_{3,2}}{t_5-t_3} + \frac{(t_6-u)N_{4,2}}{t_6-t_4} = \frac{u-1}{2} N_{3,2} + \frac{4-u}{2} N_{4,2} \\ &= \frac{(u-1)^2}{2} N_{3,1} + \left[\frac{(u-1)(3-u)}{2} + \frac{(4-u)(u-2)}{2} \right] N_{4,1} + \frac{(4-u)^2}{2} N_{5,1} \end{aligned}$$

Example – cont'

$$\begin{aligned} N_{4,3}(\mathbf{u}) &= \frac{(\mathbf{u} - \mathbf{t}_4)N_{4,2}}{\mathbf{t}_6 - \mathbf{t}_4} + \frac{(\mathbf{t}_7 - \mathbf{u})N_{5,2}}{\mathbf{t}_7 - \mathbf{t}_5} = \frac{\mathbf{u} - 2}{2} N_{4,2} + (4 - \mathbf{u})N_{5,2} \\ &= \frac{(\mathbf{u} - 2)^2}{2} N_{4,1} + \left[\frac{(\mathbf{u} - 2)(4 - \mathbf{u})}{2} + (4 - \mathbf{u})(\mathbf{u} - 3) \right] N_{5,1} \end{aligned}$$

$$N_{5,3}(\mathbf{u}) = \frac{(\mathbf{u} - \mathbf{t}_5)N_{5,2}}{\mathbf{t}_7 - \mathbf{t}_5} + \frac{(\mathbf{t}_8 - \mathbf{u})N_{6,2}}{\mathbf{t}_8 - \mathbf{t}_6} = (\mathbf{u} - 3)N_{5,2} = (\mathbf{u} - 3)^2 N_{5,1}$$

Example – cont'

$$\begin{aligned}\therefore \mathbf{P}(u) &= (1-u)^2 N_{2,1} \mathbf{P}_0 + \left\{ \left[u(1-u) + \frac{(2-u)u}{2} \right] N_{2,1} + \frac{(2-u)^2}{2} N_{3,1} \right\} \mathbf{P}_1 \\ &+ \left\{ \frac{u^2}{2} N_{2,1} + \left[\frac{u(2-u)}{2} + \frac{(3-u)(u-1)}{2} \right] N_{3,1} + \frac{(3-u)^2}{2} N_{4,1} \right\} \mathbf{P}_2 \\ &+ \left\{ \frac{(u-1)^2}{2} N_{3,1} + \left[\frac{(u-1)(3-u)}{2} + \frac{(4-u)(u-2)}{2} \right] N_{4,1} + \frac{(4-u)^2}{2} N_{5,1} \right\} \mathbf{P}_3 \\ &+ \left\{ \frac{(u-2)^2}{2} N_{4,1} + \left[\frac{(u-2)(4-u)}{2} + (4-u)(u-3) \right] N_{5,1} \right\} \mathbf{P}_4 \\ &+ (u-3)^2 N_{5,1} \mathbf{P}_5\end{aligned}$$

Example – cont'

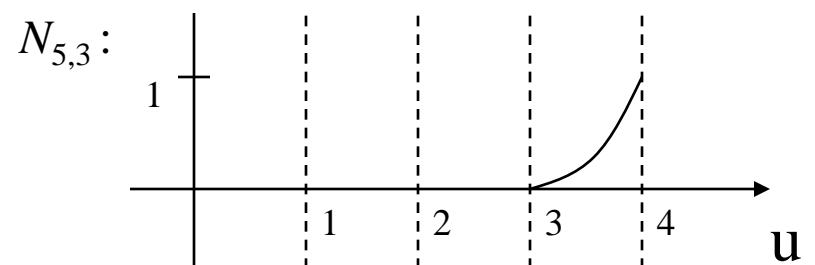
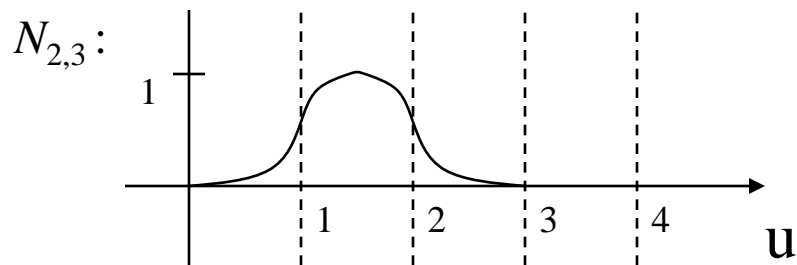
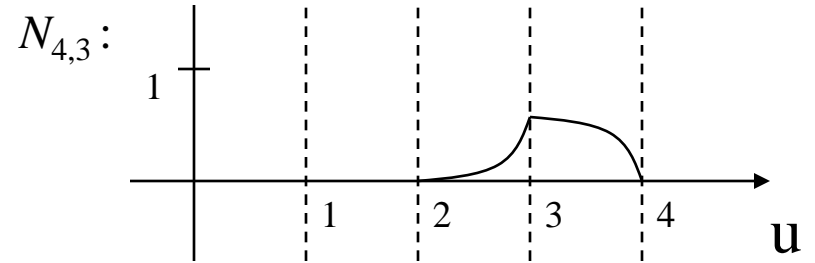
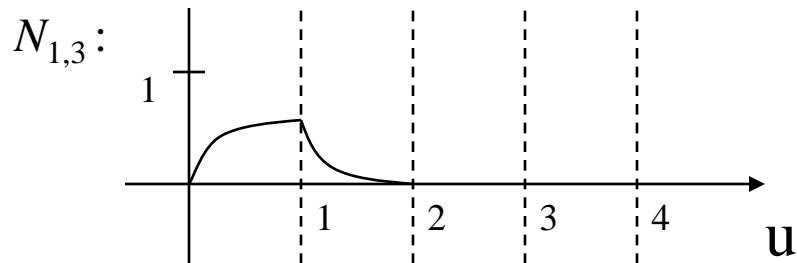
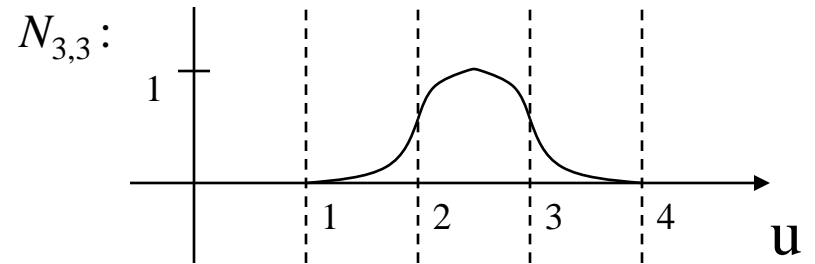
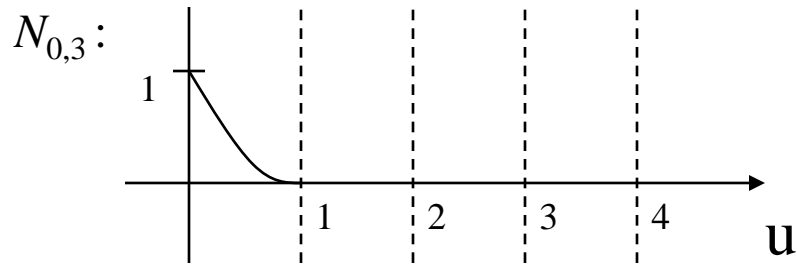

Example – cont'

- ▶ For each knot interval, coefficients of certain control points = 0
 - ▶ only subset of control points has influence
- ▶ For $0 \leq u \leq 1$, all $N_{i,1}$ except $N_{2,1}$ are 0

$$\therefore \mathbf{P}_1(u) = (1-u)^2 \mathbf{P}_0 + \left[u(1-u) + \frac{(2-u)u}{2} \right] \mathbf{P}_1 + \frac{u^2}{2} \mathbf{P}_2$$

Example – cont'

▶ Similarly

$$1 \leq u \leq 2$$

$$\mathbf{P}_2(u) = \frac{(2-u)^2}{2} \mathbf{P}_1 + \left[\frac{u(2-u)}{2} + \frac{(3-u)(u-1)}{2} \right] \mathbf{P}_2 + \frac{(u-1)^2}{2} \mathbf{P}_3$$

$$2 \leq u \leq 3$$

$$\mathbf{P}_3(u) = \frac{(3-u)^2}{2} \mathbf{P}_2 + \frac{1}{2} (-2u^2 + 10u - 11) \mathbf{P}_3 + \frac{(u-2)^2}{2} \mathbf{P}_4$$

$$3 \leq u \leq 4$$

$$\mathbf{P}_4(u) = \frac{(4-u)^2}{2} \mathbf{P}_3 + \frac{1}{2} (-3u^2 + 20u - 32) \mathbf{P}_4 + (u-3)^2 \mathbf{P}_5$$

Example – cont'

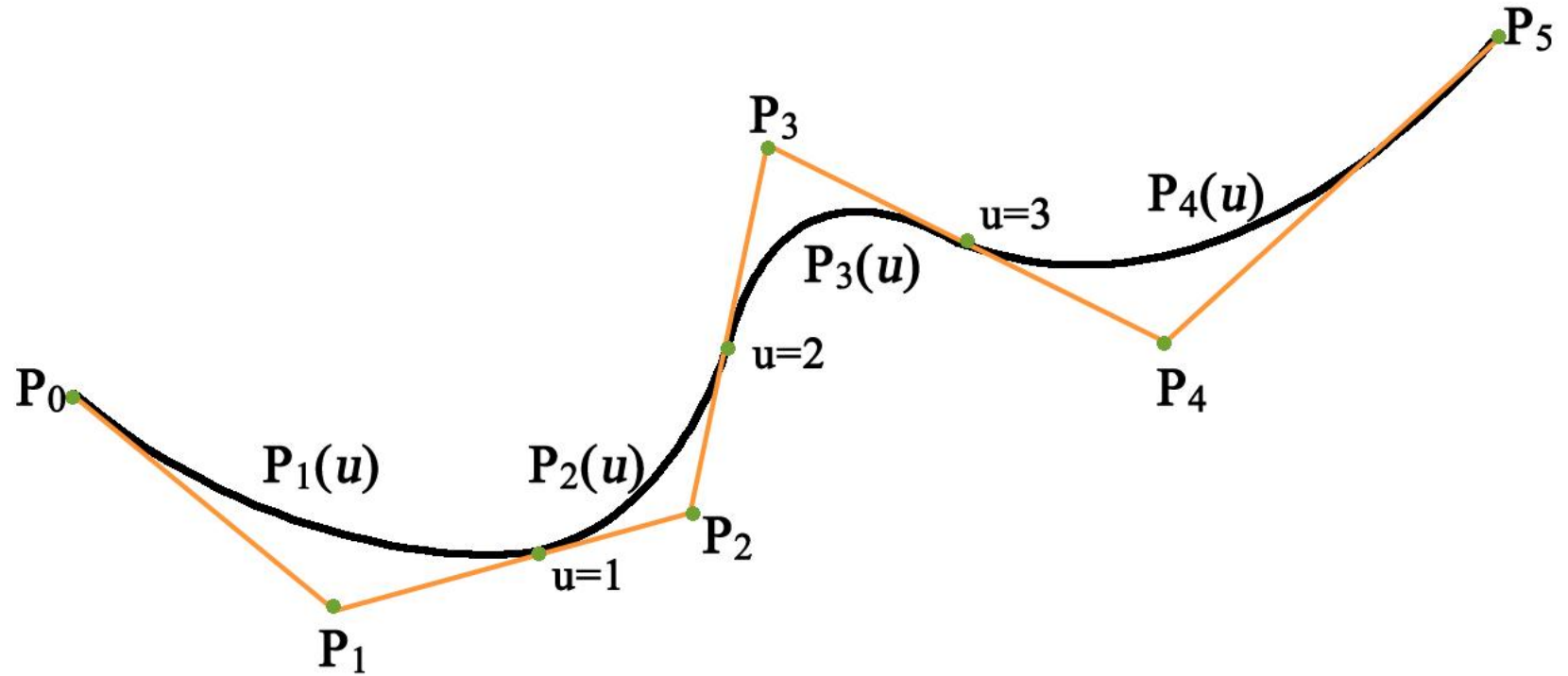

Example – cont'

- ▶ $\mathbf{P}'_1(1) = \mathbf{P}'_2(1)$, $\mathbf{P}'_2(2) = \mathbf{P}'_3(2)$, $\mathbf{P}'_3(3) = \mathbf{P}'_4(3)$ C^1 continuity
- ▶ C^2 continuity is not satisfied. ($\because k=3$, degree 2)
 - ▶ For curve of order k , neighboring curves have same derivatives up to $(k-2)$ -th derivative at the common knot
- ▶ Each curve segment is defined by k control points.
- ▶ Any one control point can influence up to maximum k curve segments.

Example – cont'

count curve segment including \mathbf{P}_{k-1}

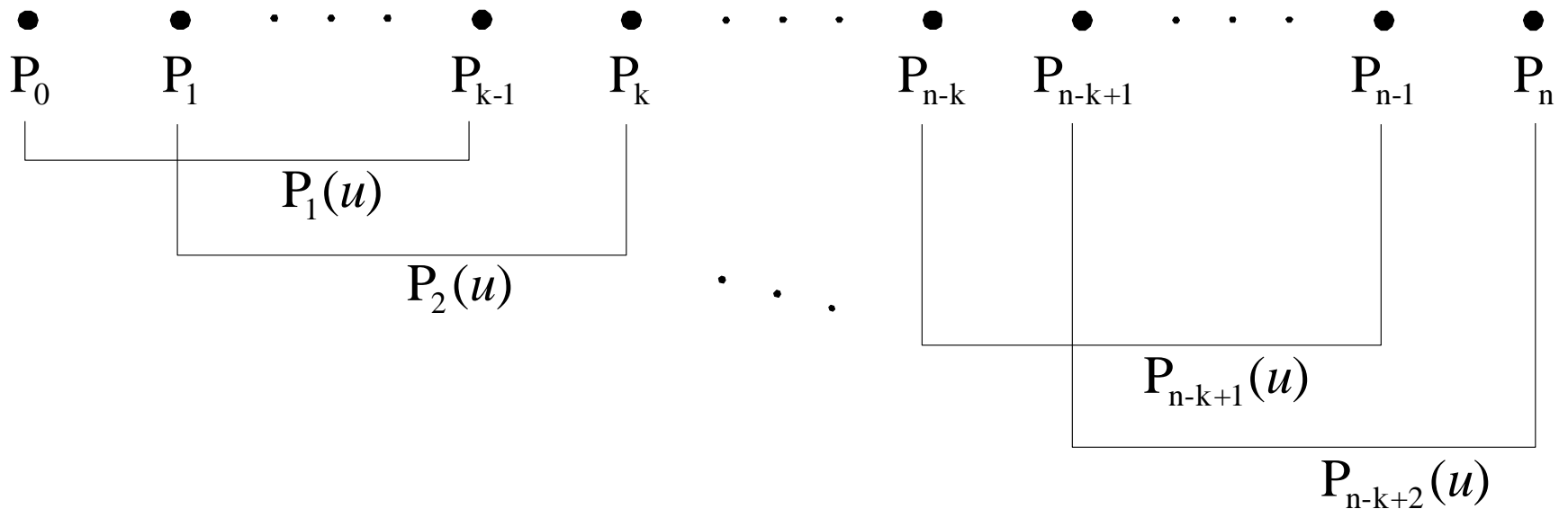

Intersection between curves

- ▶ $\mathbf{P(u) - Q(v) = 0}$
- ▶ 3 scalar equations, two unknowns
 - ▶ $P_x(u) - Q_x(v) = 0$
 - ▶ $P_y(u) - Q_y(v) = 0$
- ▶ Use Newton Raphson method
 - ▶ Derivative of P_x, Q_x, P_y, Q_y need to be calculated
 - ▶ $f_1(x_1, \dots, x_n) = 0$
 - ▶ $f_2(x_1, \dots, x_n) = 0$
 - ▶ \vdots
 - ▶ $f_n(x_1, \dots, x_n) = 0$

Intersection between curves – cont'

$$f_1(x_1 + \Delta x_1, x_2 + \Delta x_2, \dots, x_n + \Delta x_n) = f_1(x_1, \dots, x_n) + \frac{\partial f_1}{\partial x_1} \Delta x_1 + \dots + \frac{\partial f_1}{\partial x_n} \Delta x_n$$

⋮

$$f_n(x_1 + \Delta x_1, x_2 + \Delta x_2, \dots, x_n + \Delta x_n) = f_n(x_1, \dots, x_n) + \frac{\partial f_n}{\partial x_1} \Delta x_1 + \dots + \frac{\partial f_n}{\partial x_n} \Delta x_n$$

$$\begin{bmatrix} \frac{\partial f_1}{\partial x_1} & \dots & \frac{\partial f_1}{\partial x_n} \\ \frac{\partial f_2}{\partial x_1} & \dots & \frac{\partial f_2}{\partial x_n} \\ \vdots & & \vdots \\ \frac{\partial f_n}{\partial x_1} & \dots & \frac{\partial f_n}{\partial x_n} \end{bmatrix} \begin{bmatrix} \Delta x_1 \\ \Delta x_2 \\ \vdots \\ \Delta x_n \end{bmatrix} = \begin{bmatrix} -f_1 \\ -f_2 \\ \vdots \\ -f_n \end{bmatrix}$$

Intersection between curves – cont'

- ▶ If initial values of u , v are too far from real solution, the iteration diverges.
- ▶ Hard to find all the intersection points.
- ▶ Cannot handle the case of overlapping curves.
- ▶ Two curves are regarded to intersect each other if they lie within numerical tolerance.
- ▶ Control polygons are approximated to the curve by subdivision and initial values of u, v can be provided closely by intersecting control polygons
- ▶ Better to detect special situation in advance before resorting to numerical solution.
- ▶ Tuning tolerance values is necessary

Straight line vs. curve

- ▶ $P(u) = P_0 + u(P_1 - P_0)$
- ▶ $Q(v) = P_0 + u(P_1 - P_0) \quad (a)$
- ▶ Apply dot product $(P_0 \times P_1)$ to both sides of eq(a) gives

$$(P_0 \times P_1) \cdot Q(v) = 0$$

non-linear equation of v

Non-uniform Rational B-spline (NURBS) curve

- ▶ Use same Blending functions as B-spline
- ▶ Control points are given in homogeneous coordinates

$$(x_i, y_i, z_i) \Rightarrow (x_i \cdot h_i, y_i \cdot h_i, z_i \cdot h_i, h_i)$$

$$x \cdot h = \sum_{i=0}^n (h_i \cdot x_i) N_{i,k}(u)$$

$$y \cdot h = \sum_{i=0}^n (h_i \cdot y_i) N_{i,k}(u)$$

$$z \cdot h = \sum_{i=0}^n (h_i \cdot z_i) N_{i,k}(u)$$

$$h = \sum_{i=0}^n h_i N_{i,k}(u)$$

Non-uniform Rational B-spline (NURBS) curve – cont'

$$P(u) = \frac{\sum_{i=0}^n h_i P_i N_{i,k}(u)}{\sum_{i=0}^n h_i N_{i,k}(u)}$$

Passes through the 1st and the last control points

(When non-periodic knots are used)

Numerator is B-spline with $h_i P_i$ as control points

→ \mathbf{Z} $h_0 P_0, h_n P_n$ at parameter boundary values

Similarly denominator has values of h_0, h_n at parameter boundary values

Non-uniform Rational B-spline (NURBS) curve – cont'

Directions of tangent vectors are $P_1 - P_0$, $P_n - P_{n-1}$ at starting and ending points

$$h_i = 1 \quad \sum_{i=0}^n N_{i,k}(u) = 1 \quad \Rightarrow \quad B\text{-spline}$$

B-spline curve is a special case of NURBS

Non-uniform Rational B-spline (NURBS) curve – cont'

- ▶ Curve shape can be changed by changing weight(h_i)
- ▶ Increasing weight has an effect of pulling curve toward associated control point
 - ▶ [Example program](#)
- ▶ Conic curve can be represented exactly
 - ▶ Reducing program coding effort

Control points of NURBS curve equivalent to a circular arc

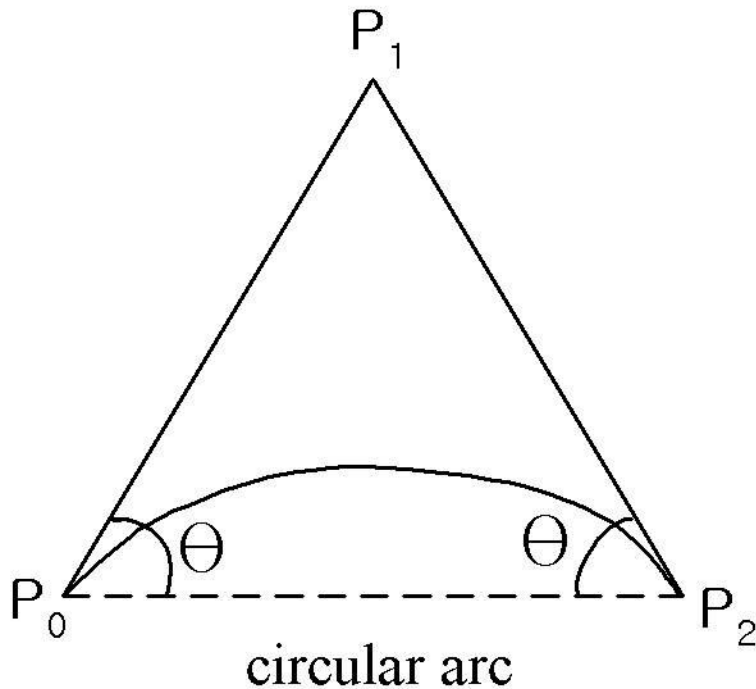

$$h_0 = h_2 = 1$$
$$h_1 = \cos \Theta$$

Can be used when center angle is less than 180° .

Arc with a center angle bigger than 180° is split into two and combined later

Example

Ex.

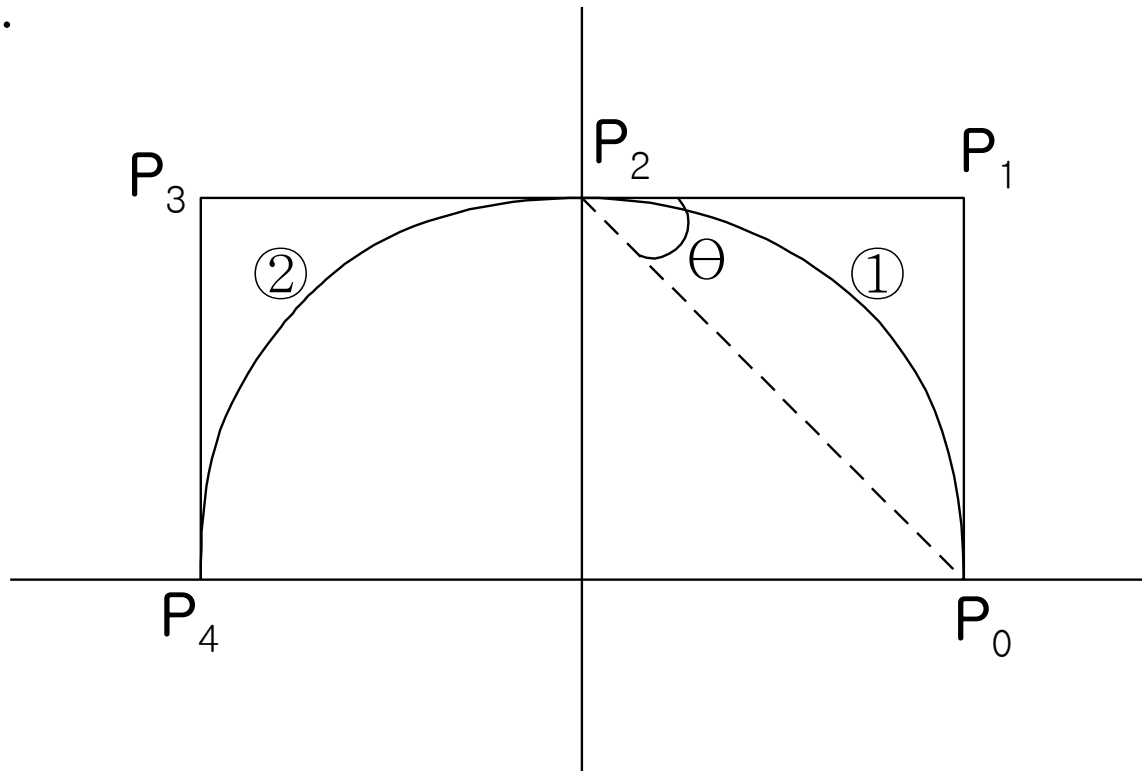

Example – cont'

$$P_0 = (1, 0), \quad P_1 = (1, 1), \quad P_2 = (0, 1)$$

$$h_0 = 0 \quad h_1 = \cos 45^\circ = \frac{1}{\sqrt{2}} \quad h_2 = 1$$

$$\text{knot } 0 \ 0 \ 0 \ 1 \ 1 \ 1 \ (n=2, k=3)$$

$$\text{Similarly} \quad \stackrel{\text{I}}{\leftarrow} P_2 = (0, 1), \quad P_3 = (-1, 1), \quad P_4 = (-1, 0)$$

$$h_2 = 1, \quad h_3 = \frac{1}{\sqrt{2}}, \quad h_4 = 1$$

$$\text{knot } 0 \ 0 \ 0 \ 1 \ 1 \ 1 \Rightarrow 1 \ 1 \ 1 \ 2 \ 2 \ 2$$

Example – cont'

Composition

$$P_0 = (1, 0), \quad P_1 = (1, 1), \quad P_2 = (0, 1),$$

$$P_3 = (-1, 1), \quad P_4 = (-1, 0)$$

$$h_0 = 1 \quad h_1 = \frac{1}{\sqrt{2}} \quad h_2 = 1$$

$$h_3 = \frac{1}{\sqrt{2}}, \quad h_4 = 1$$

$$\textit{knot} \quad 0 \quad 0 \quad 0 \quad 1 \quad 1 \quad 2 \quad 2 \quad 2$$