

Fabry-Perot 필터, 펄스 레이저의 원리

이병호

서울대학교 전기공학부

byoungcho@snu.ac.kr

Tel : 02) 880-7245 Fax : 02)873-9953



Fabry-Perot Etalon (I)

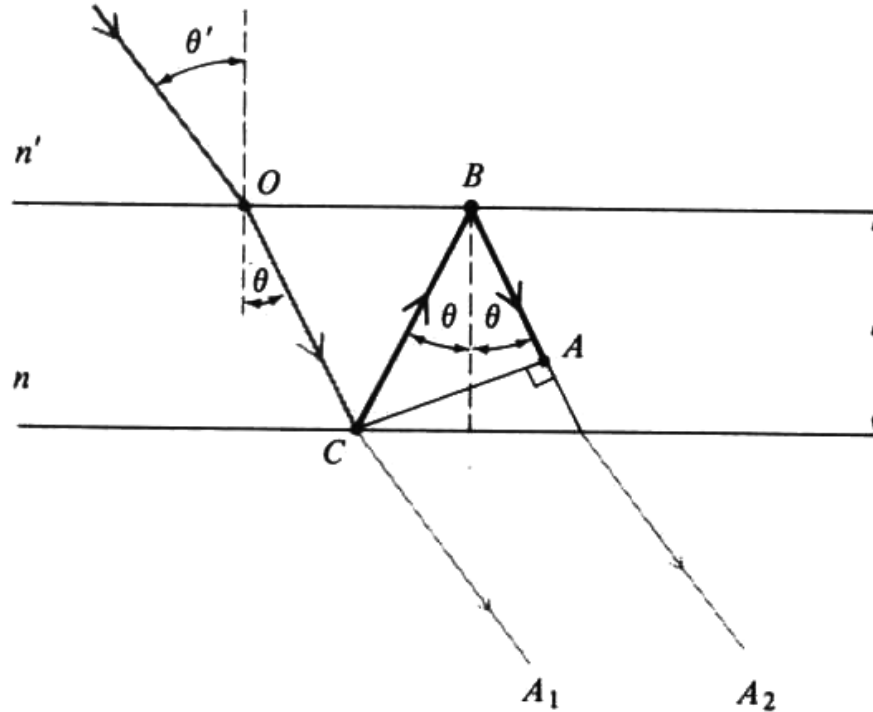

Two successive reflections, A_1 and A_2 . Their path difference is given by

$$\delta L = AB + BC = l \frac{\cos 2\theta}{\cos \theta} + \frac{l}{\cos \theta} = 2l \cos \theta \quad \rightarrow \quad \delta = \frac{2\pi(\delta L)n}{\lambda} = \frac{4\pi n l \cos \theta}{\lambda}$$



Fabry-Perot Etalon (II)

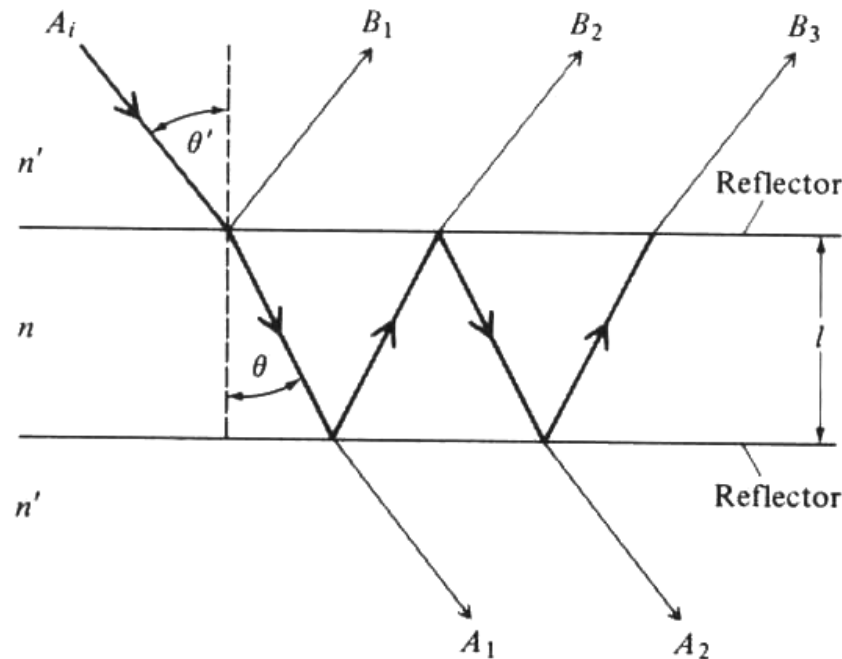

Multiple reflections model for analyzing the Fabry-Perot etalon.

$$B_1 = rA_i, \quad B_2 = tt'r'A_i e^{i\delta}, \quad B_3 = tt'(r')^3 A_i e^{2i\delta}, \dots$$

$$A_1 = tt'A_i, \quad A_2 = tt'(r')^2 e^{i\delta} A_i, \quad A_3 = tt'(r')^4 e^{2i\delta} A_i, \dots$$



Fabry-Perot Etalon (III)

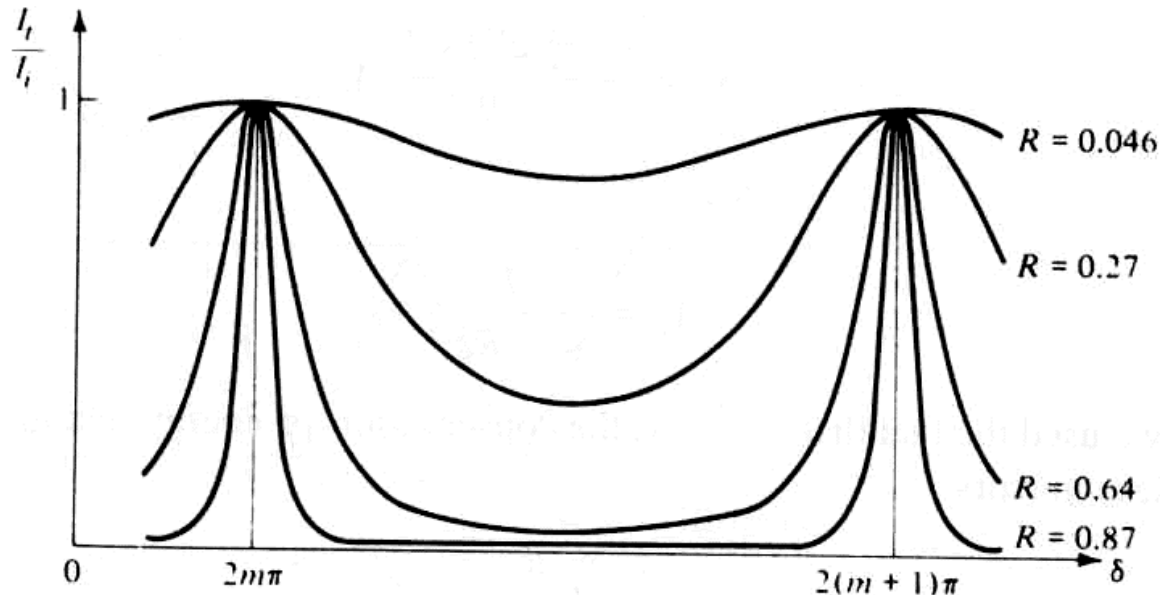

Transmission characteristics(theoretical) of a Fabry-Perot etalon

$$\frac{I_t}{I_i} = \frac{(1-R)^2}{(1-R)^2 + 4R \sin^2(\delta/2)}, \quad R = r^2 = (r')^2$$

$$v_m = m \frac{c}{2nl \cos \theta} \quad m = \text{integer} \quad \Delta v = v_{m+1} - v_m = \frac{c}{2nl \cos \theta}$$

$$\Delta v_{1/2} = \frac{\Delta v}{F}, \quad F = \text{finesse factor}, \quad F = \frac{\pi \sqrt{R}}{1-R}$$



Fabry-Perot Etalon (IV)

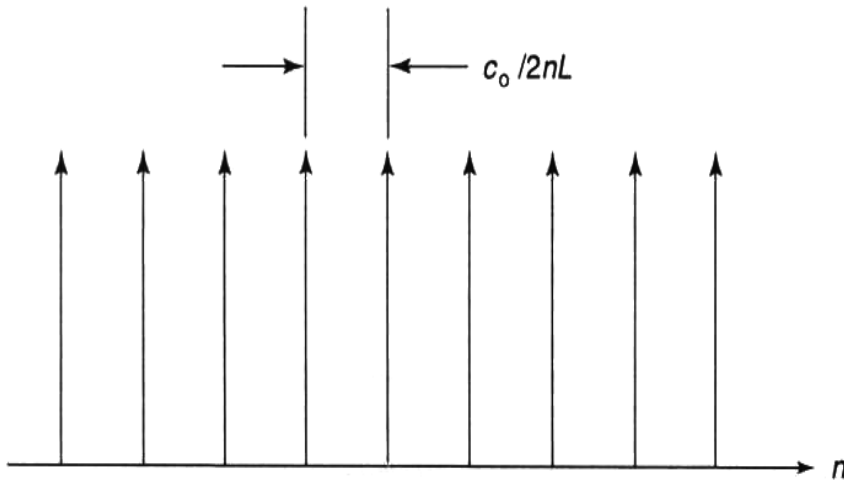

An etalon is a piece of glass with two plane parallel reflective surfaces. It will transmit a comb of frequencies separated by $(c_0/2nL)$

The transmittance spectra for two etalons with thicknesses of 2mm, etalon indices of refraction of 1.5, and reflectances (on both surfaces) of $R = 50\%$ and $R = 90\%$. The laser is an argon-ion laser operating at a center wavelength of 514.5nm and the beam is entering the etalons at normal incidence

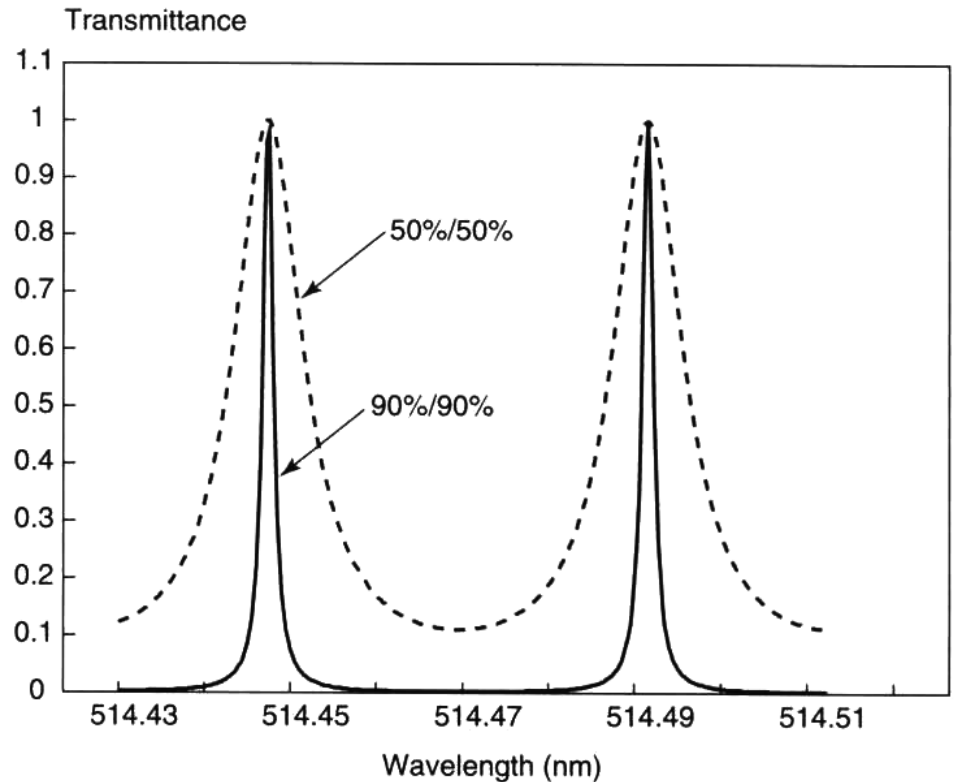

Fabry-Perot Etalon (V)

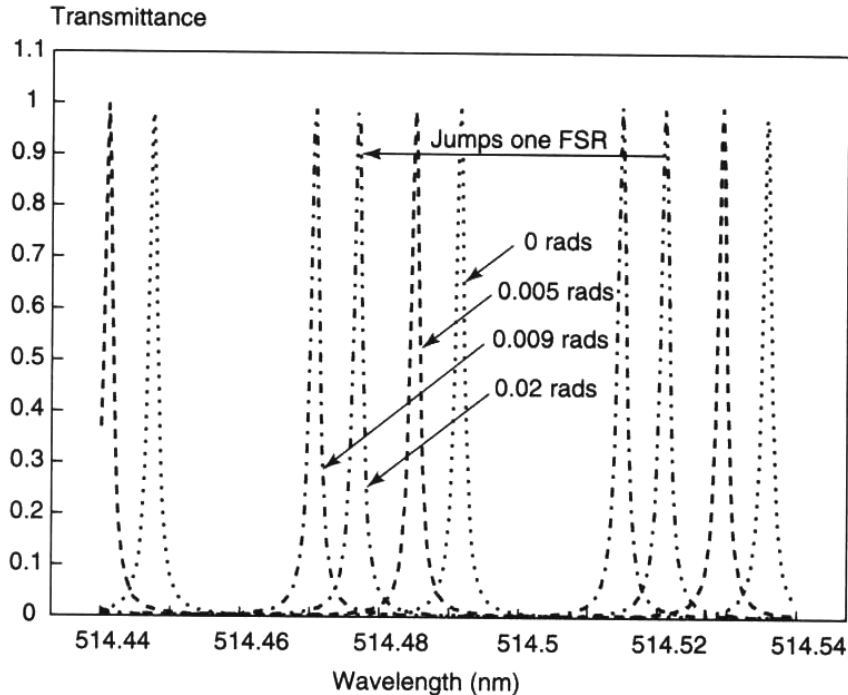

The transmittance of a Fabry-Perot etalon for several values of angle. In this case, a Fabry-Perot etalon is used with an argon-ion laser operating at a center wavelength of 514.5nm. The etalon thickness is 2mm, the etalon index of refraction is 1.5, and both surfaces have reflectances of 90%. The angle values are $\theta_t=0$ radians, $\theta_t=0.005$ radians, $\theta_t=0.009$ radians, and $\theta_t=0.02$ radians.

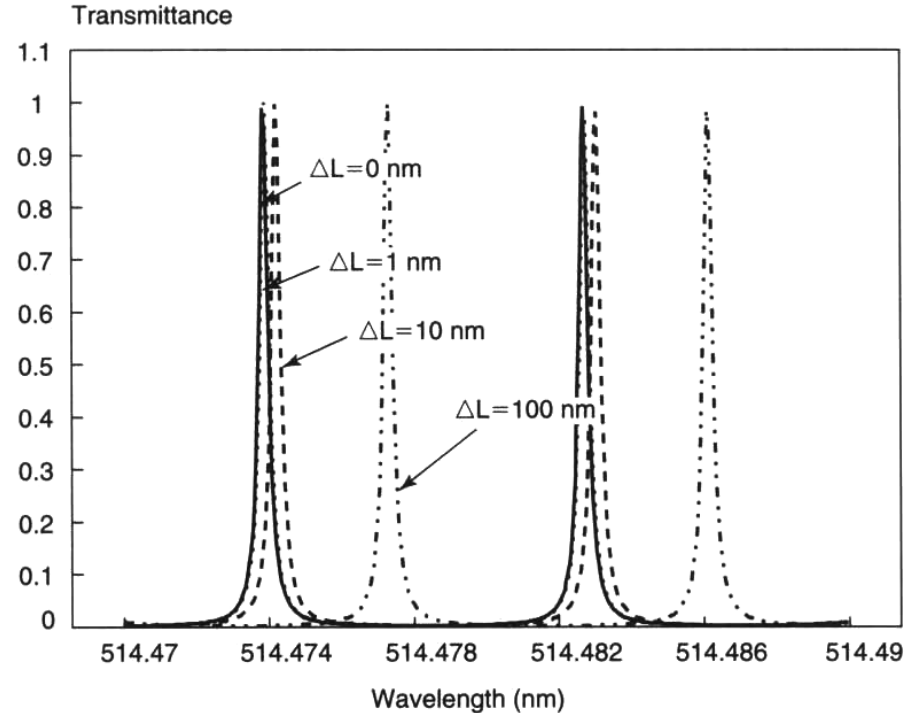

The transmittance of a Fabry-Perot etalon for several values of length. In this case, a Fabry-Perot etalon is used with an argon-ion laser operating at a center wavelength of 514.5nm. The etalon thickness is 15mm, the etalon index of refraction is 1.0, and $\theta_t=0$. The length values are $L=15\text{mm}+0\text{nm}$, $L=15\text{mm}+1\text{nm}$, $L=15\text{mm}+10\text{nm}$, and $L=15\text{mm}+100\text{nm}$.



Scanning Fabry-Perot Filter

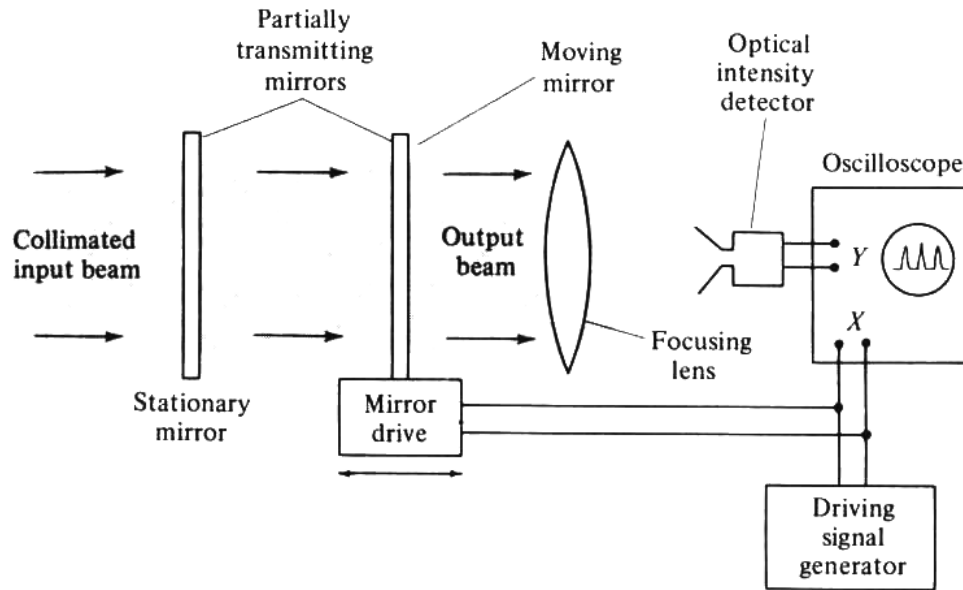

Typical scanning Fabry-Perot interferometer experimental arrangement.

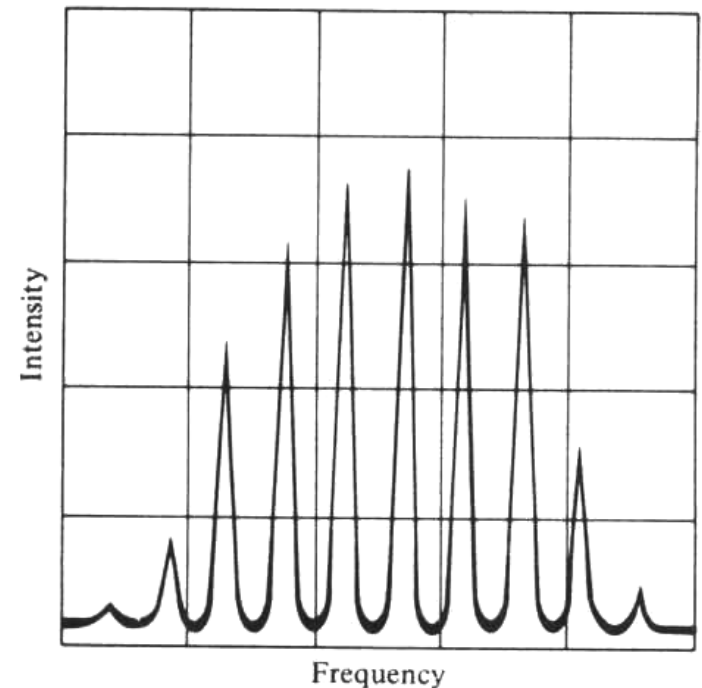

Intensity versus frequency analysis of the output of a He-Ne 6328 Å laser obtained with a scanning Fabry-Perot etalon. The horizontal scale is 250MHz per division.



Fabry-Perot Etalon for Longitudinal Mode Selection in Laser

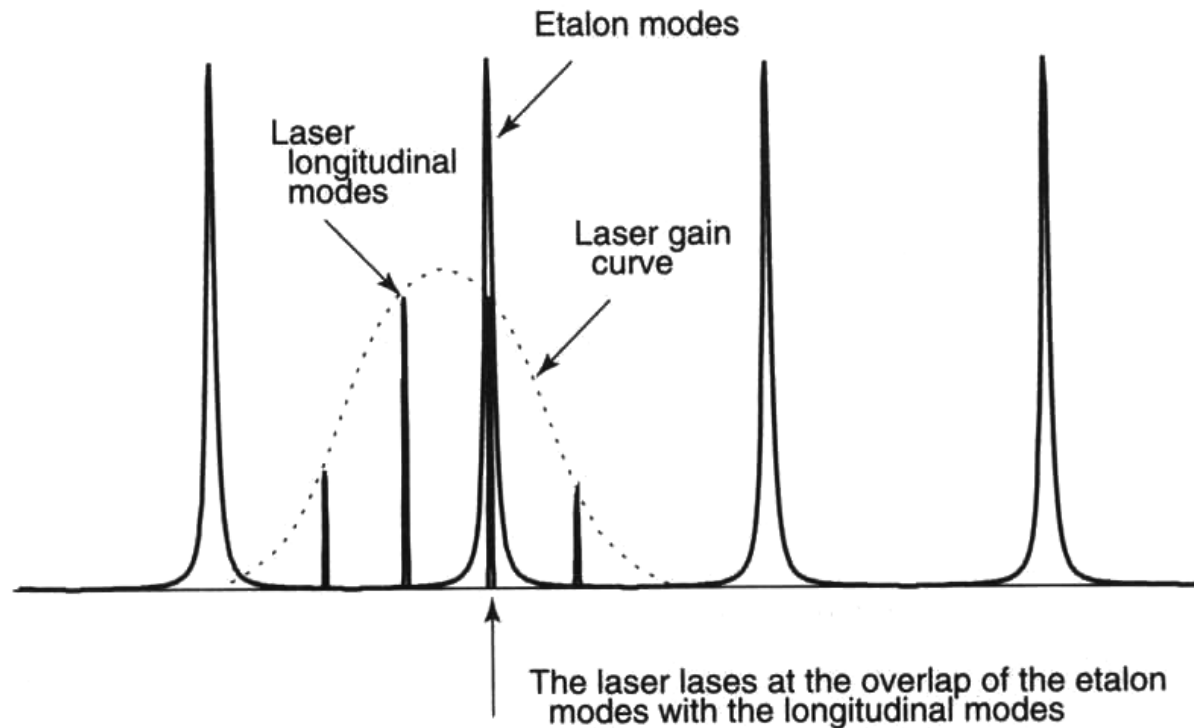

Single frequency operation of a laser can be obtained by placing an etalon inside the laser cavity. The laser will lase in the one longitudinal mode that represents the transmission overlap between the laser modes and the etalon modes.



Q-Switching and Mode Locking

■ Q-Switching

Artificially induced relaxation oscillations in order to generate a *high-intensity pulse*

$Q = \text{패스당 저장된 에너지} / \text{패스당 흩어진 에너지}$

■ Mode Locking

Short-pulse generation by controlling the relative phases and magnitudes of the various longitudinal modes in the laser



Q-Switching

Principle of the operation

- ⇒ *The quality factor Q of the optical resonator of laser is degraded, i.e., the losses are increased.*
- ⇒ *The population inversion, i.e., the gain builds up to a very high value.*
- ⇒ *The Q is restored, i.e., the losses are lowered.*
- ⇒ *The gain is now well above the lowered oscillation threshold value.*
- ⇒ *A giant pulse is generated.*

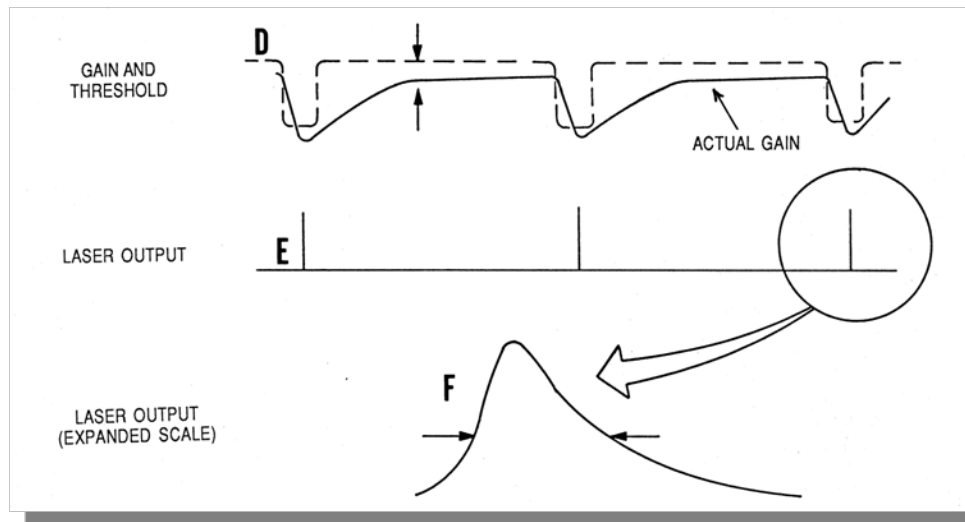

Mechanical Q-Switch

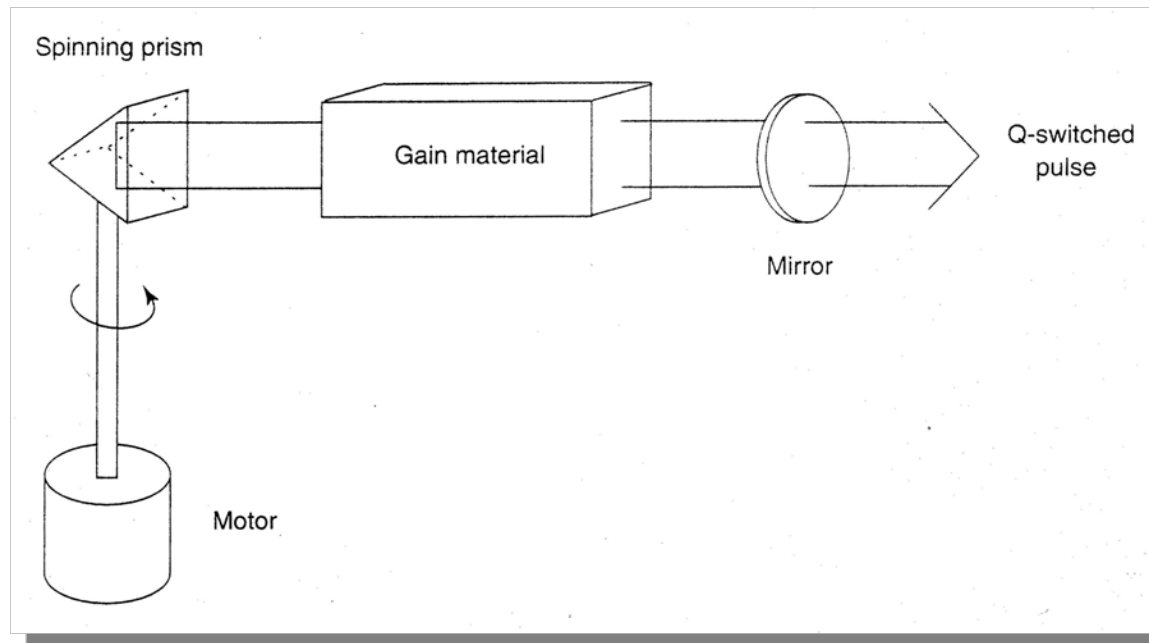

Electro-Optic Q-Switch

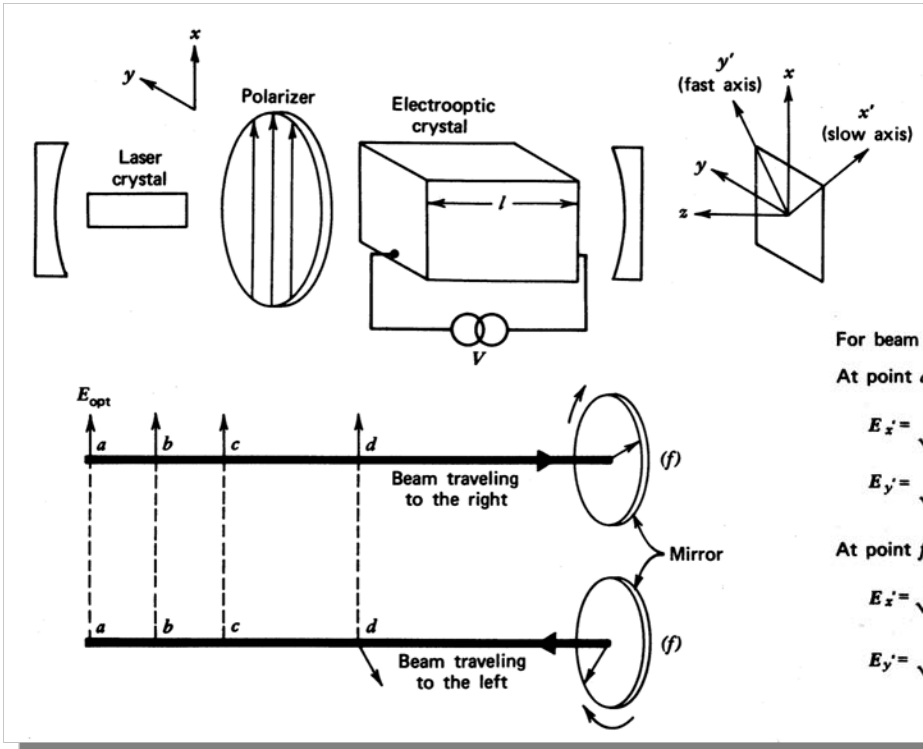

For beam traveling to right:

At point d ,

$$\left. \begin{aligned} E_x &= \frac{E}{\sqrt{2}} \cos \omega t \\ E_y &= \frac{E}{\sqrt{2}} \cos \omega t \end{aligned} \right\} \begin{array}{l} \text{The optical field is linearly} \\ \text{polarized with its electric} \\ \text{field vector parallel to } x \end{array}$$

At point f ,

$$\left. \begin{aligned} E_x &= \frac{E}{\sqrt{2}} \cos (\omega t - kl - \frac{\pi}{2}) \\ E_y &= \frac{E}{\sqrt{2}} \cos (\omega t - kl) \end{aligned} \right\} \begin{array}{l} \text{Circularly} \\ \text{polarized} \end{array}$$

For beam traveling to left:

At point f ,

$$\left. \begin{aligned} E_x &= -\frac{E}{\sqrt{2}} \cos (\omega t - kl - \frac{\pi}{2}) \\ E_y &= -\frac{E}{\sqrt{2}} \cos (\omega t - kl) \end{aligned} \right\} \begin{array}{l} \text{Circularly} \\ \text{polarized} \end{array}$$

At point d ,

$$\left. \begin{aligned} E_x &= -\frac{E}{\sqrt{2}} \cos (\omega t - 2kl - \pi) \\ E_y &= -\frac{E}{\sqrt{2}} \cos (\omega t - 2kl) \end{aligned} \right\} \begin{array}{l} \text{Linearly} \\ \text{polarized} \\ \text{along } y \end{array}$$

Acousto-Optic Q-Switch

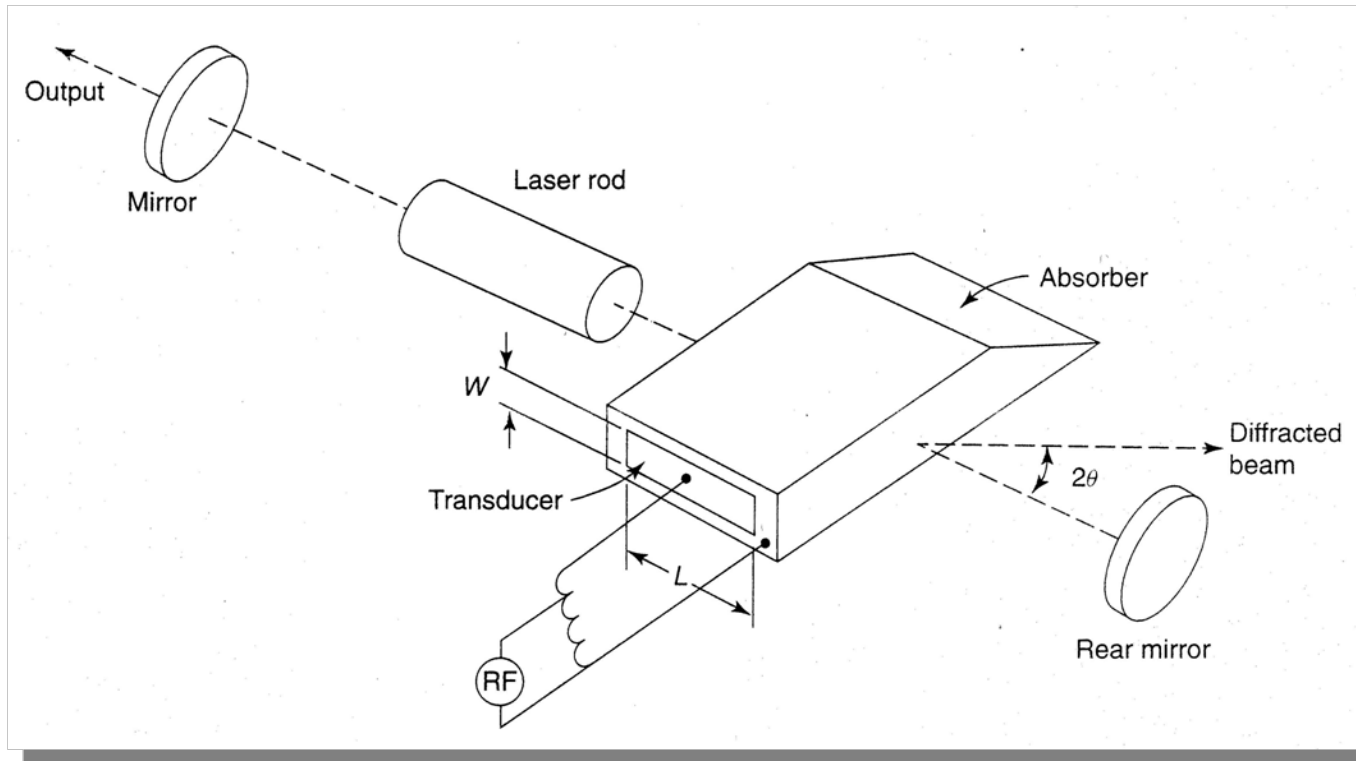

Saturable Absorber Q-Switch

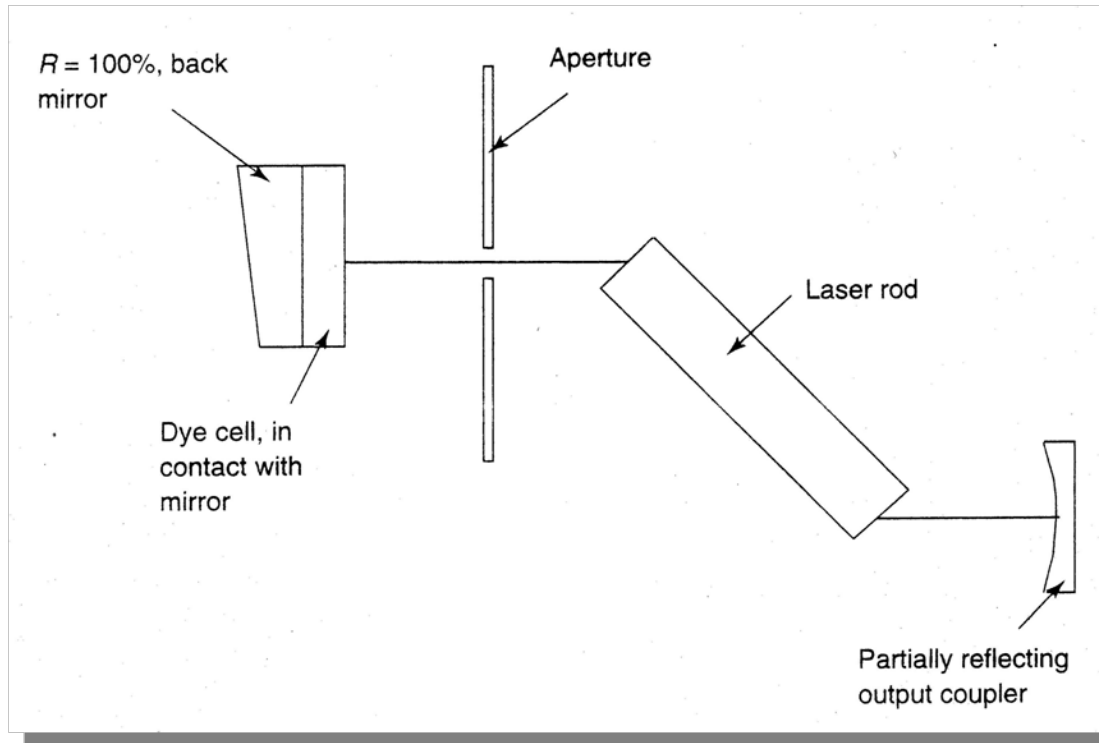

Dye Absorption

$$\alpha_{dye} = \frac{\alpha_{dye,0}}{1 + I / I_{dye}}$$

Lasing Mode(s)

*Homogeneous
Atomic System*

*Inhomogeneous
Atomic System*

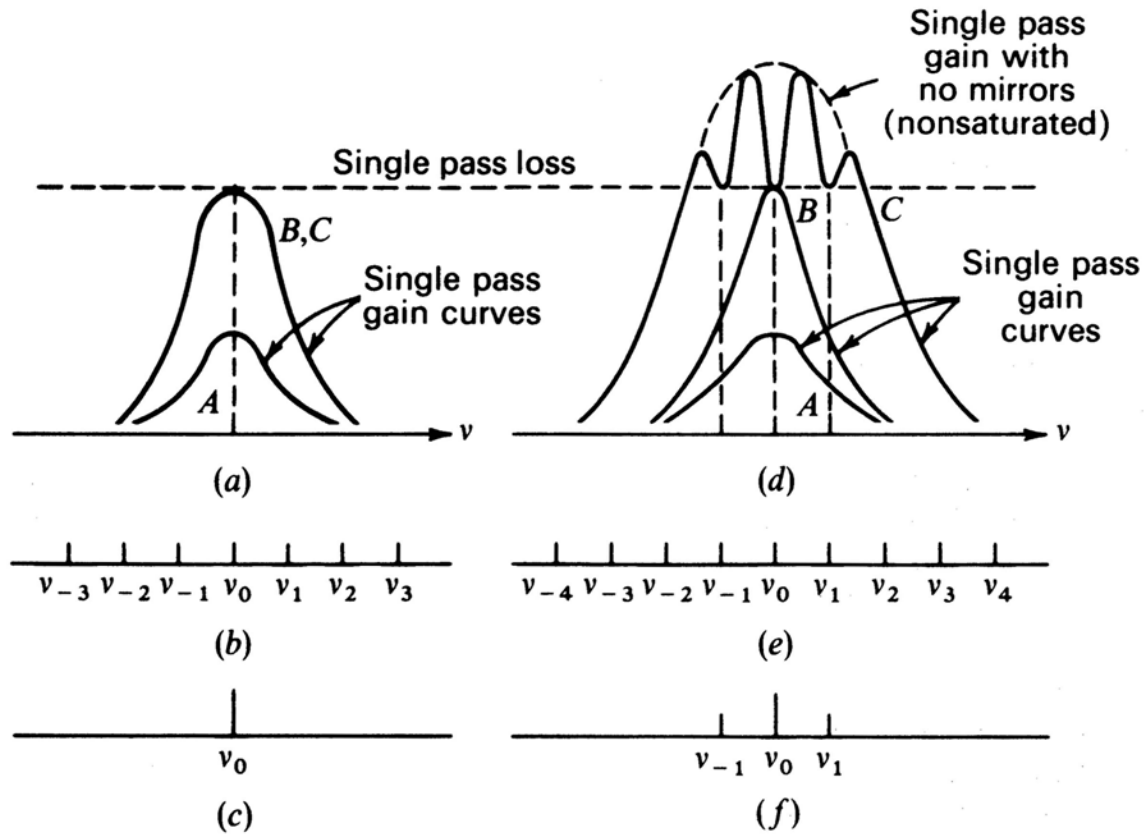

Mode Locking

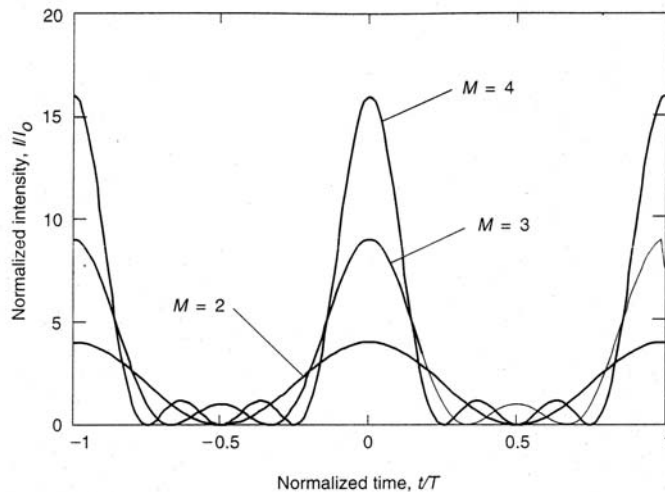
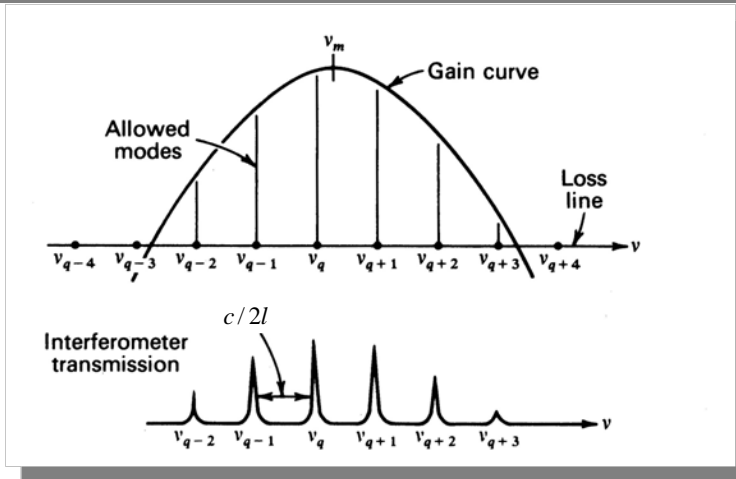

Mode Separation

$$\omega_{q+1} - \omega_q = \frac{\pi c}{l} \equiv \omega$$

공진기 모드 간격 \Rightarrow 주기함수의 푸리에 시리즈
 \Rightarrow 주기 = 공진기 왕복 시간 !!!

Total Electric Field

$$E(t) = \sum_n E_n \exp\{i[(\omega_0 + n\omega)t + \phi_n]\}$$

$$\omega_0 = m\pi c / l$$

$$T = 2\pi / \omega = 2l / c$$

If E_n and ϕ_n are fixed (locked),

$$E(t + T) = E(t).$$

Taking $E_n = 1$ and $\phi_n = 0$,

$$E(t) = \sum_{-(M-1)/2}^{(M-1)/2} \exp[i(\omega_0 + n\omega)t]$$

$$= \exp(i\omega_0 t) \frac{\sin(M\omega t / 2)}{\sin(\omega t / 2)}.$$



Method of Mode Locking

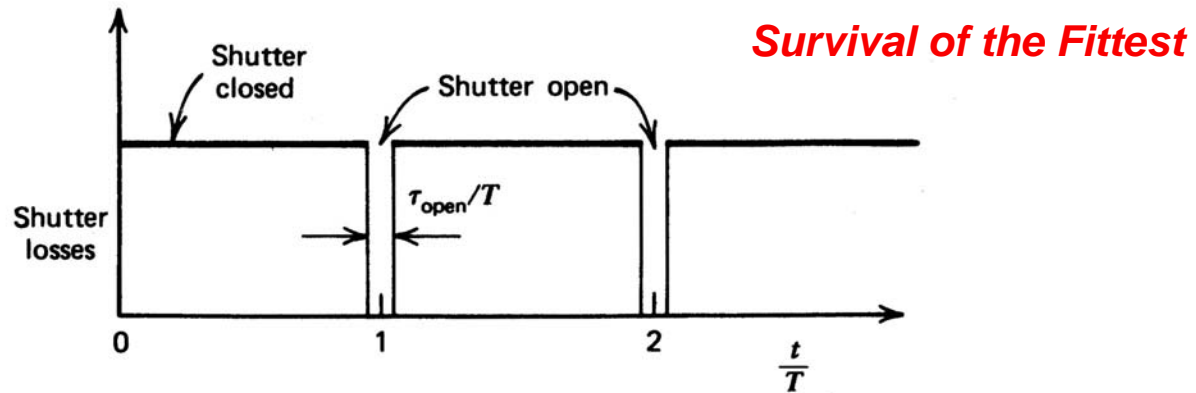
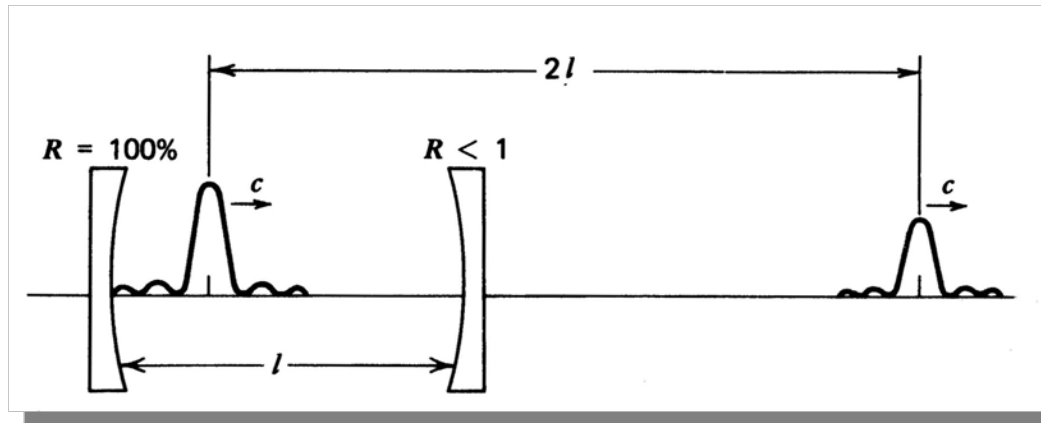

Active Mode Locking

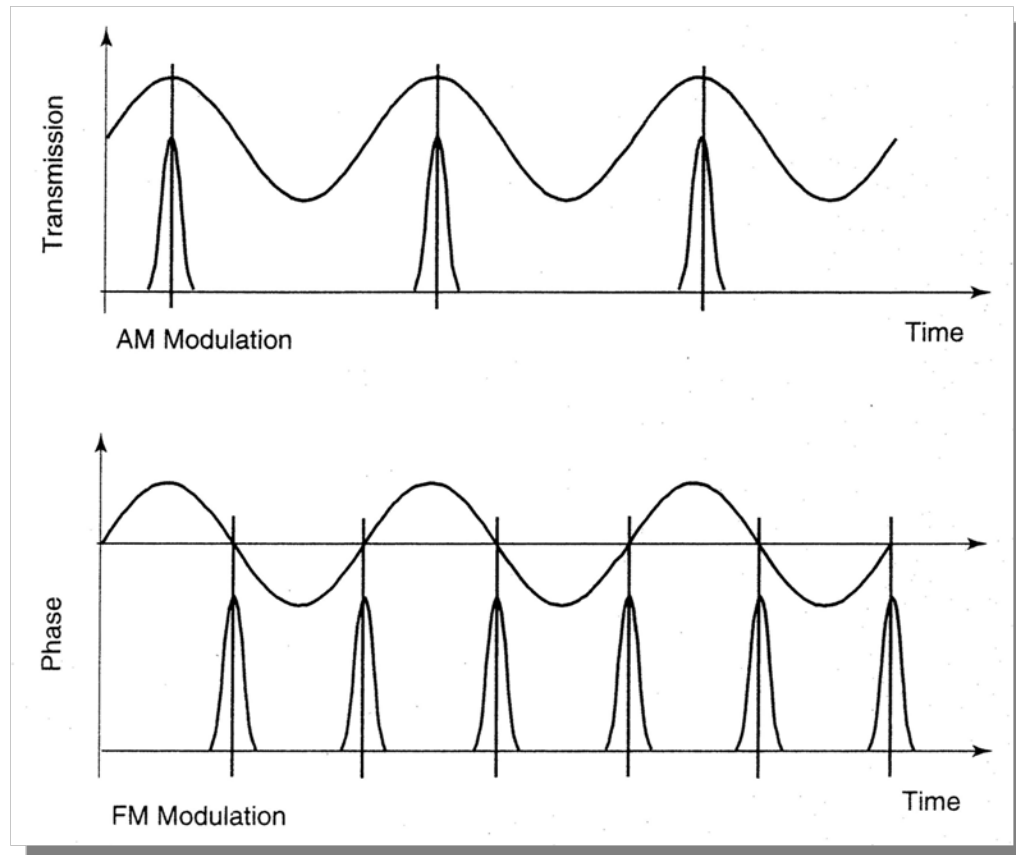

Mode Locking by Acoustic Loss Modulation

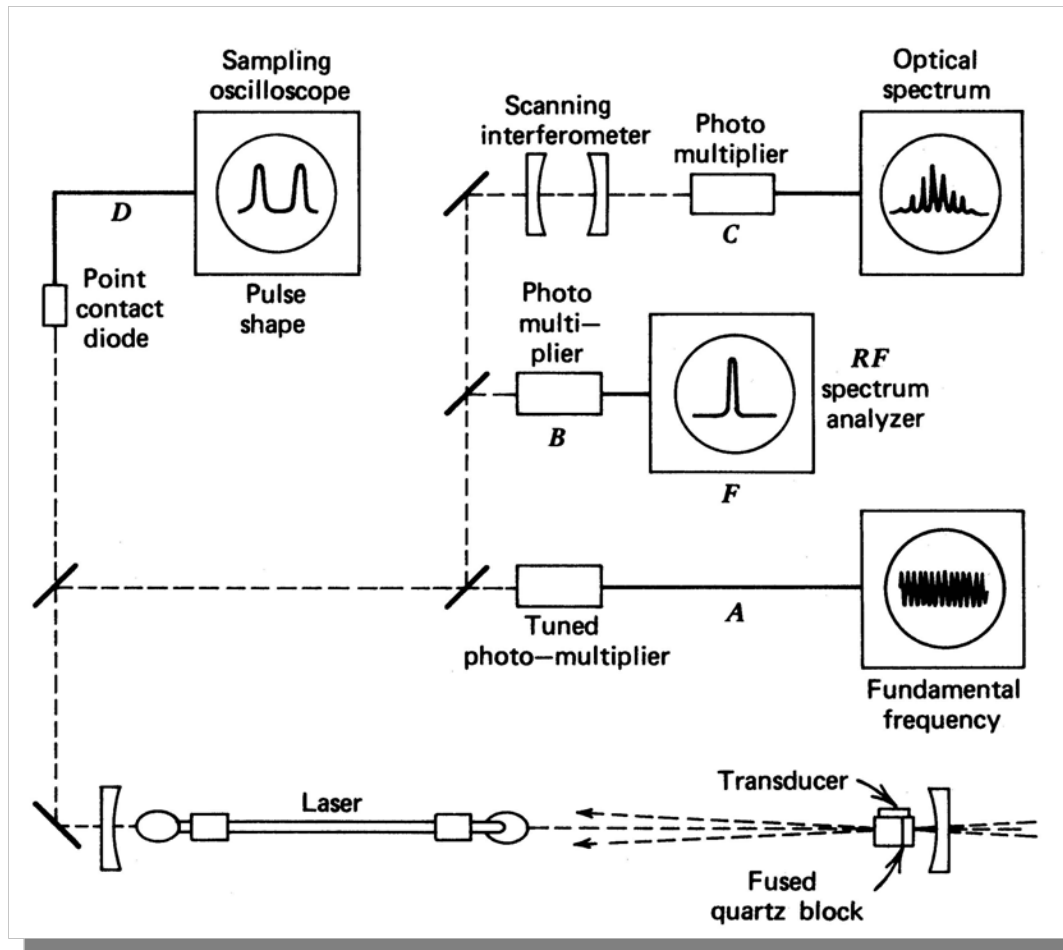

Nd:YAG Laser System (Quantronix 416)

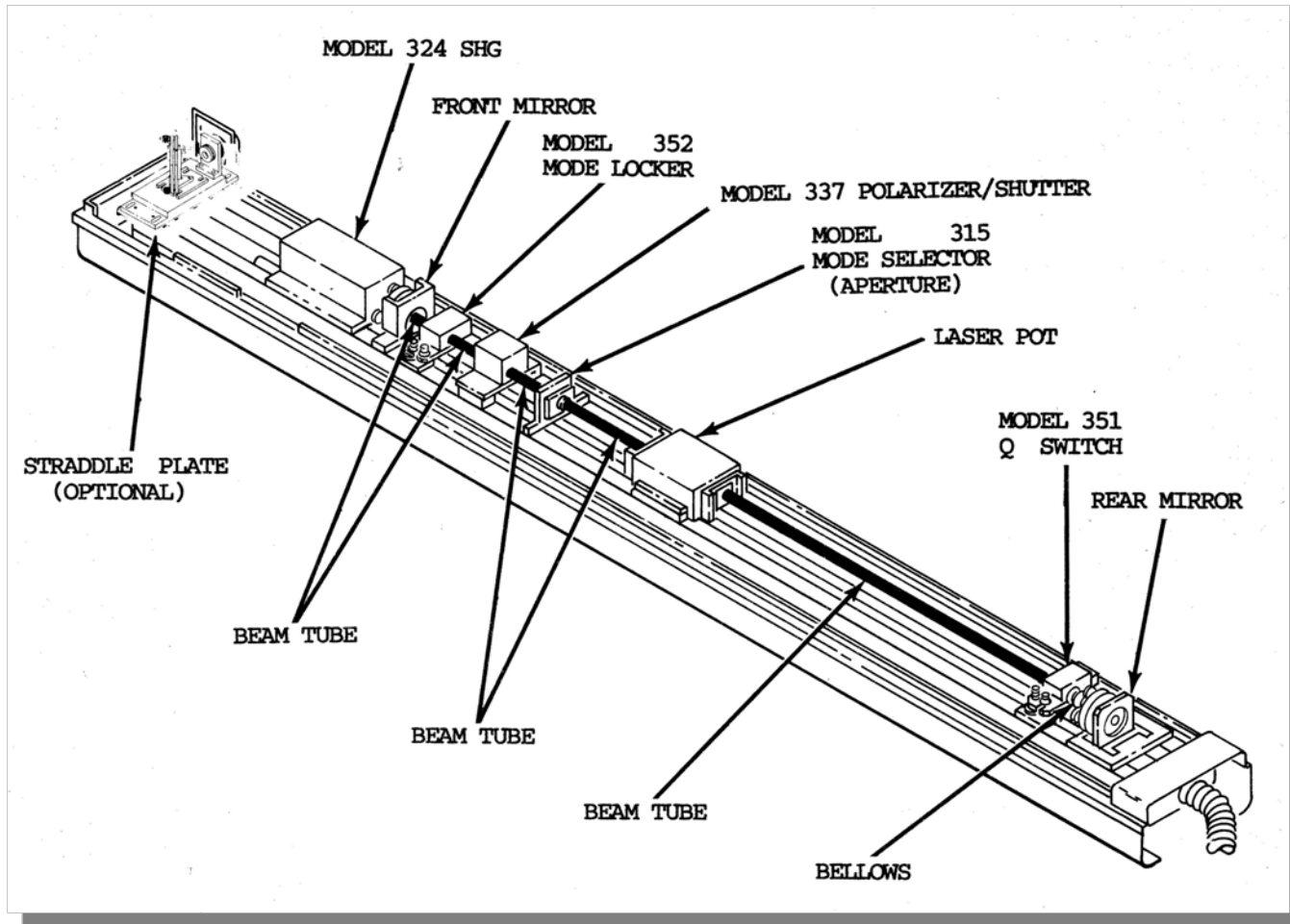

Front and Rear Mirrors

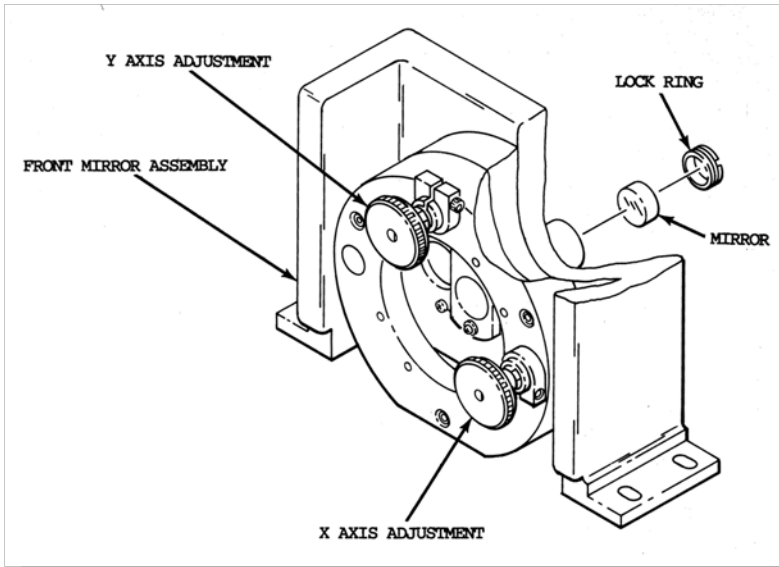

Front Mirror

Rear Mirror

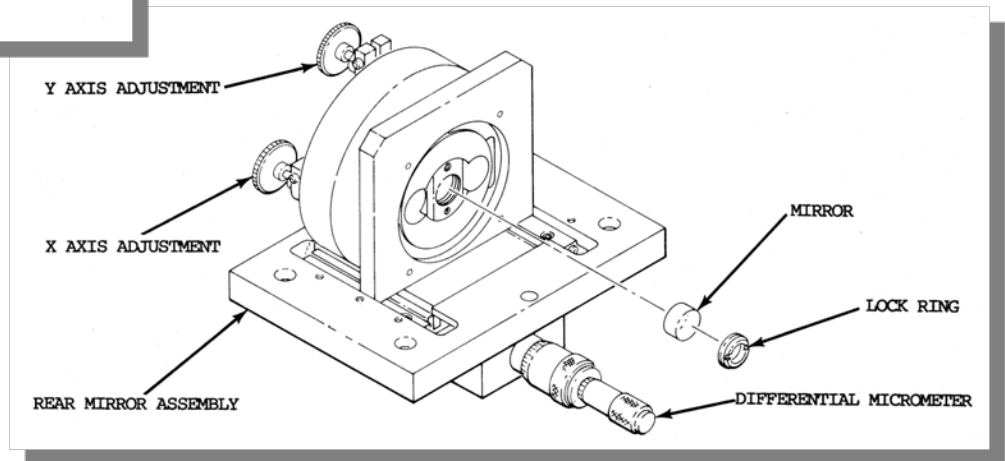

Laser Pot

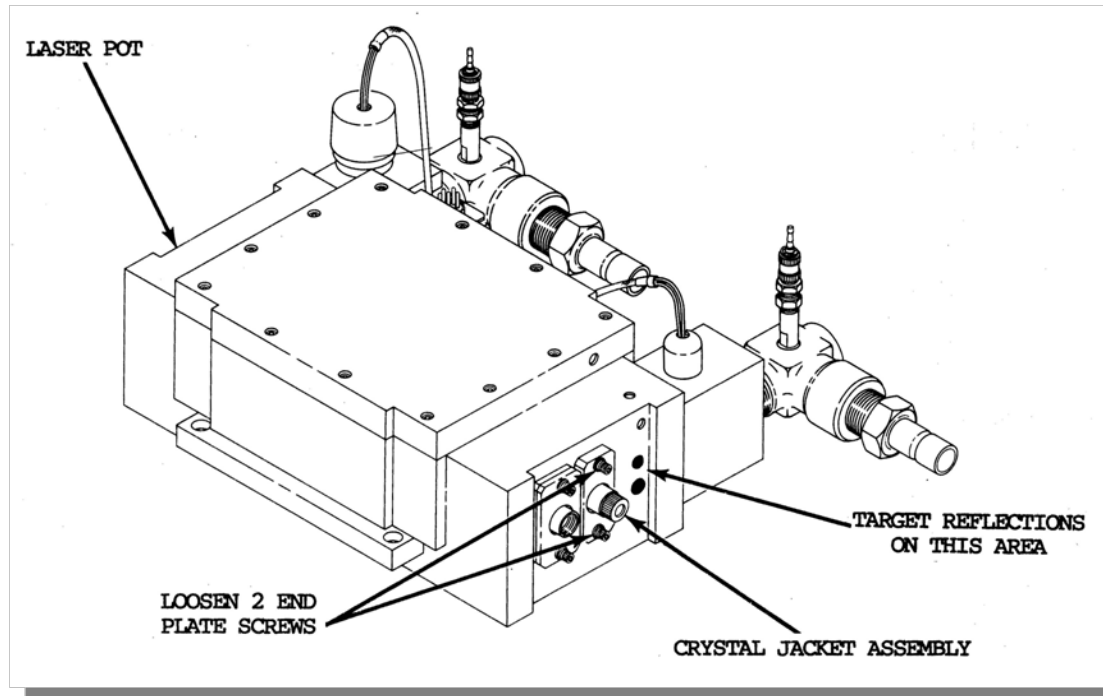

Acousto-Optic Q-Switch and Mode Locker

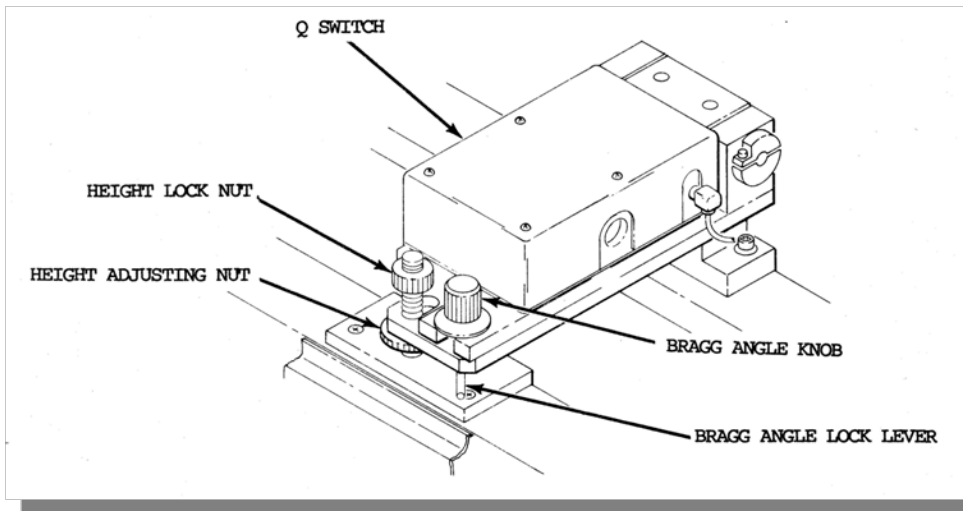

Q-Switch

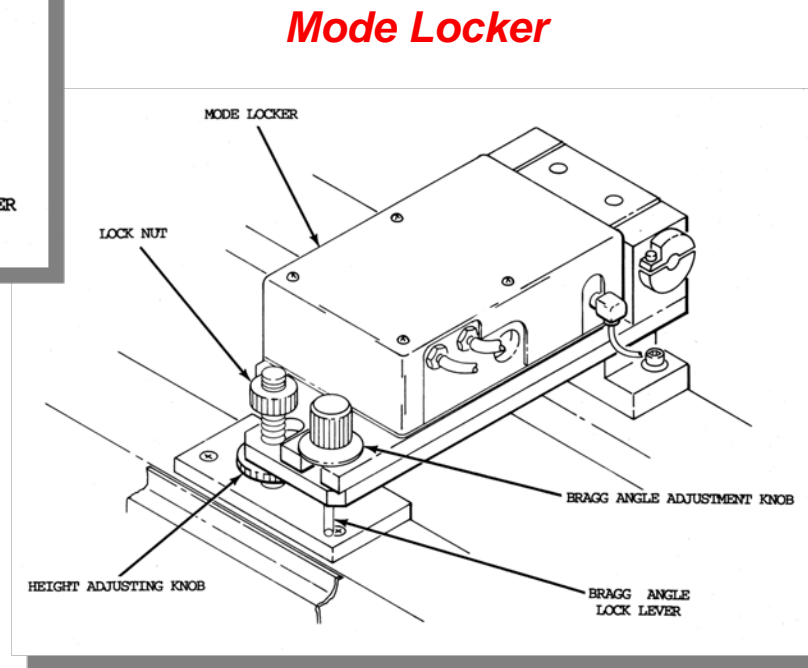

참고문헌

1. B. E. A. Saleh and M. C. Teich, *Fundamentals of Photonics*, 2nd ed., Wiley, New York, USA, 2007.
2. K. J. Kuhn, *Laser Engineering*, Prentice Hall, New York, USA, 1998.
3. A. Yariv, *Optical Electronics in Modern Communications*, 5th ed., Oxford Univ. Press, New York, USA, 1997.
4. *Quantronix-Technical Manual*, Model 416 Lasers, Quantronix Co.

