

A decorative graphic on the left side of the slide consisting of two vertical lines: a blue line on the left and an orange line on the right, both extending from the top to the bottom of the slide.

CUDA Threads

Block IDs and Thread IDs

- Each thread uses IDs to decide what data to work on
 - Block ID: 1D or 2D
 - Thread ID: 1D, 2D, or 3D
- Simplifies memory addressing when processing multidimensional data
 - Image processing
 - Solving PDEs on volumes
 - ...

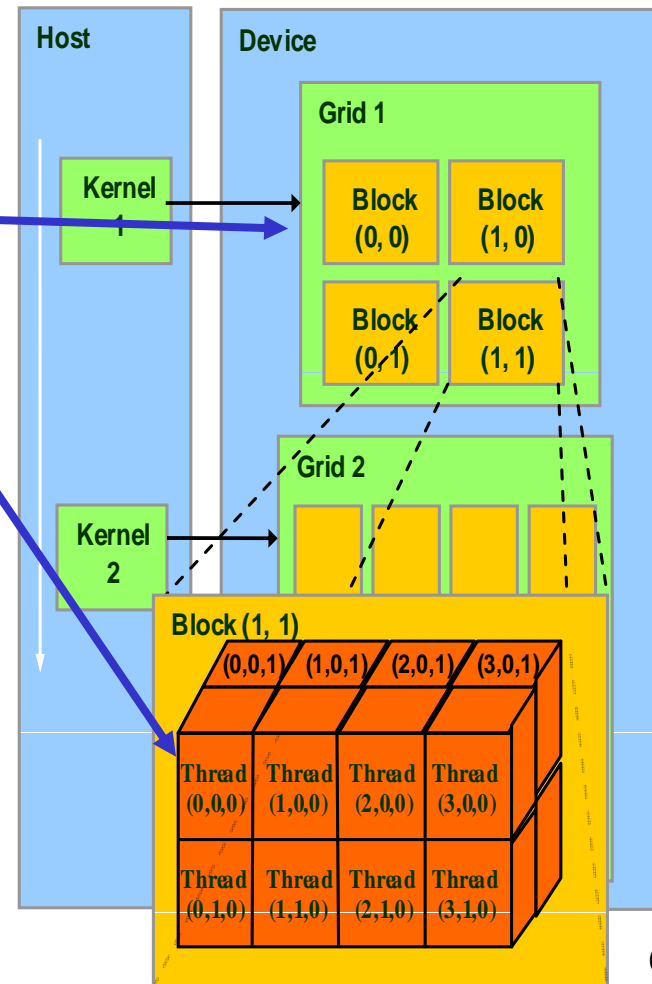

Courtesy: NVIDIA

Matrix Multiplication Using Multiple Blocks

- Break-up P_d into tiles
- Each block calculates one tile
 - Each thread calculates one element
 - Block size equal tile size

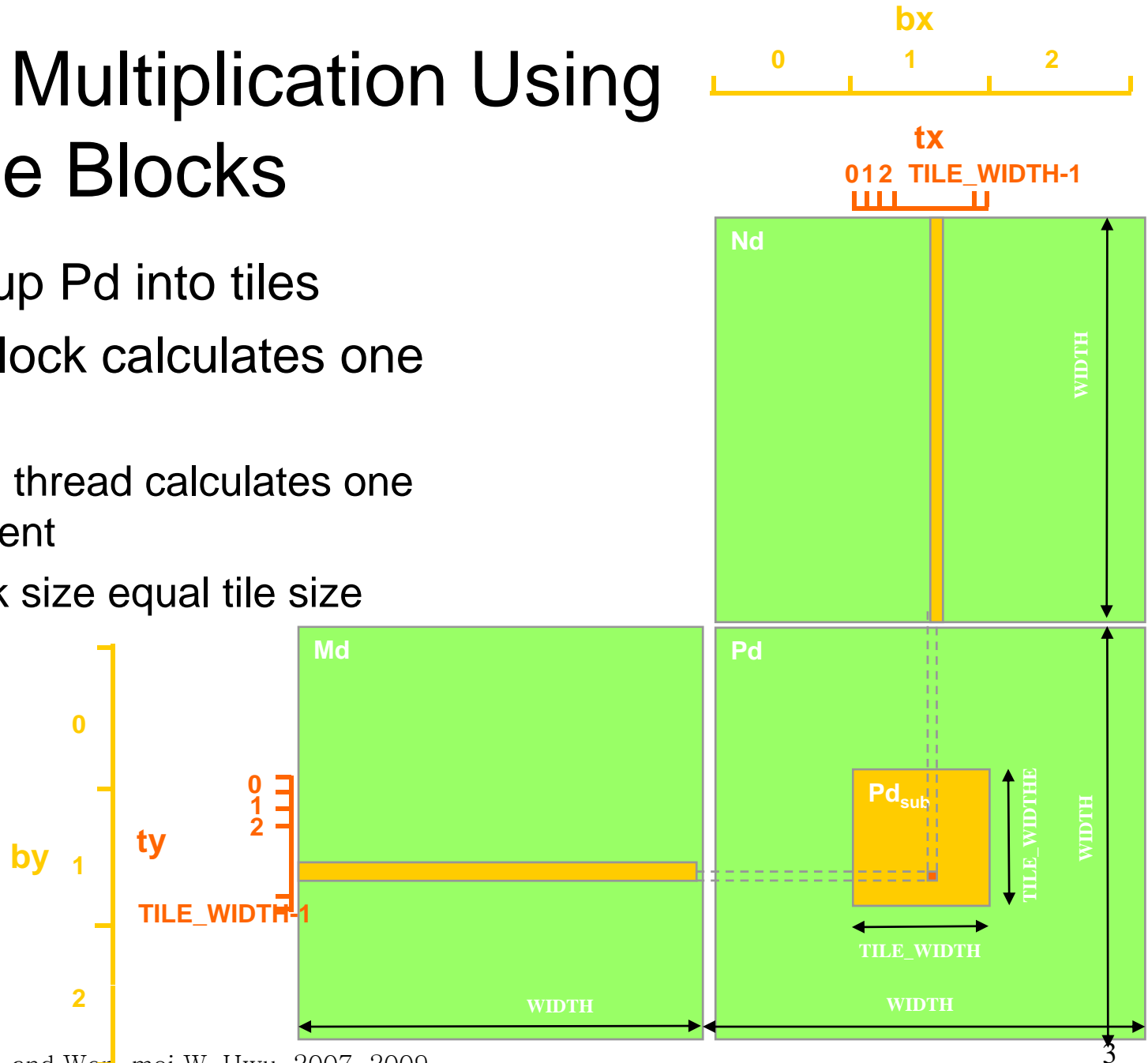

A Small Example

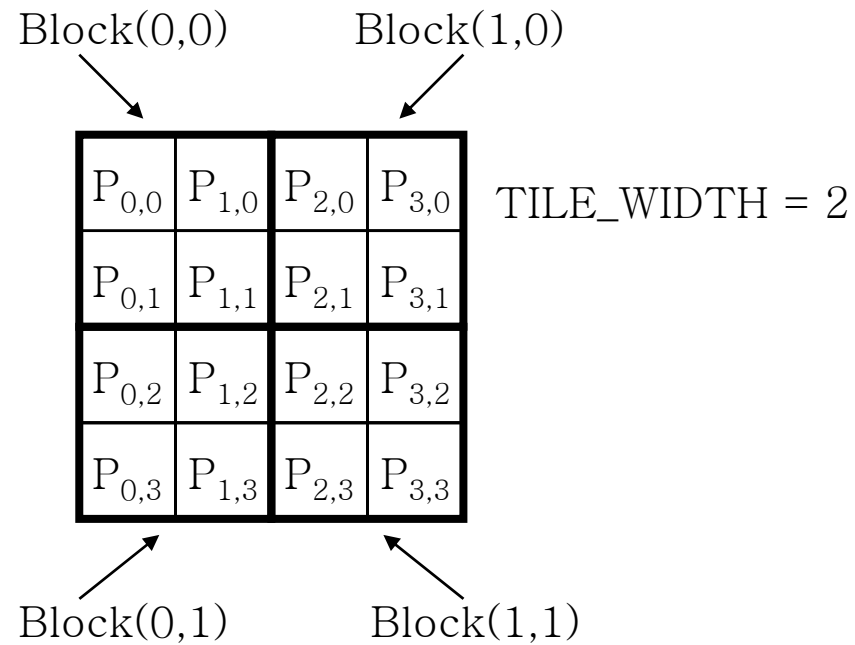

A Small Example: Multiplication

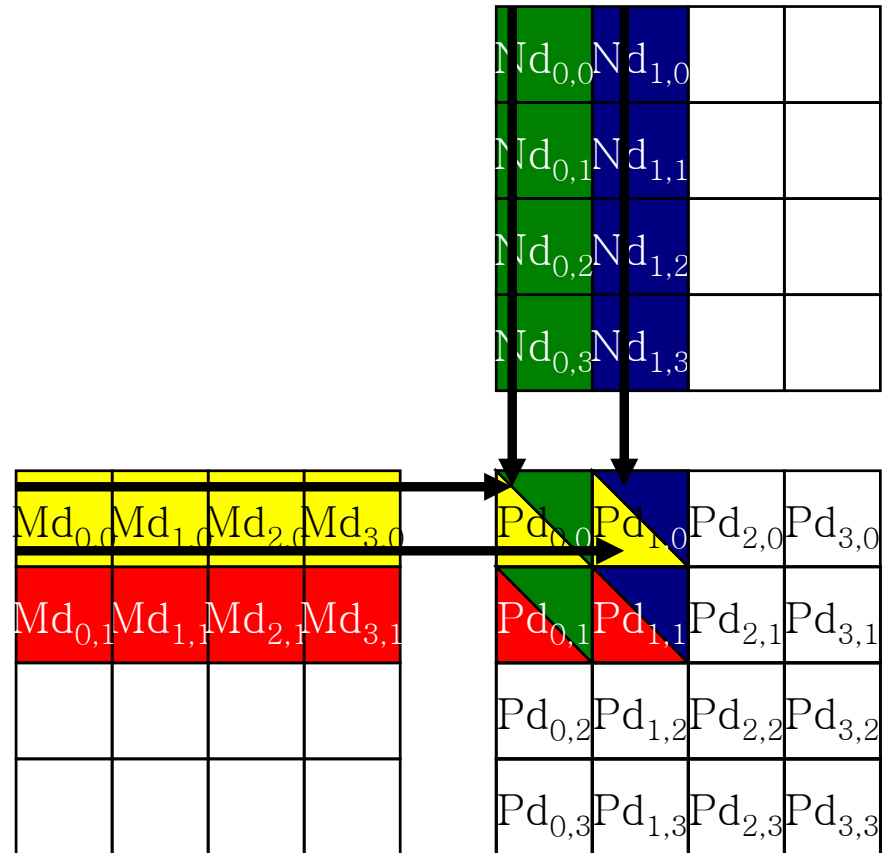

Revised Matrix Multiplication Kernel using Multiple Blocks

```
__global__ void MatrixMulKernel(float* Md, float* Nd, float* Pd, int Width)
{
    // Calculate the row index of the Pd element and M
    int Row = blockIdx.y*TILE_WIDTH + threadIdx.y;
    // Calculate the column idenx of Pd and N
    int Col = blockIdx.x*TILE_WIDTH + threadIdx.x;

    float Pvalue = 0;
    // each thread computes one element of the block sub-matrix
    for (int k = 0; k < Width; ++k)
        Pvalue += Md[Row*Width+k] * Nd[k*Width+Col];

    Pd[Row*Width+Col] = Pvalue;
}
```

CUDA Thread Block

- All threads in a block execute the same kernel program (SPMD)
- Programmer declares block:
 - Block size 1 to **512** concurrent threads
 - Block shape 1D, 2D, or 3D
 - Block dimensions in threads
- Threads have **thread id** numbers within block
 - Thread program uses **thread id** to select work and address shared data
- Threads in the same block share data and synchronize while doing their share of the work
- Threads in different blocks cannot cooperate
 - Each block can execute in any order relative to other blocs!

CUDA Thread Block

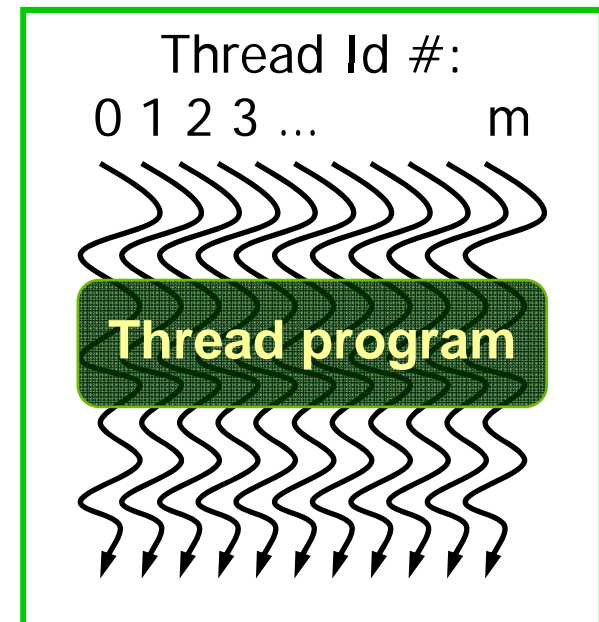

Courtesy: John Nickolls,
NVIDIA

Transparent Scalability

- Hardware is free to assign blocks to any processor at any time
 - A kernel scales across any number of parallel processors

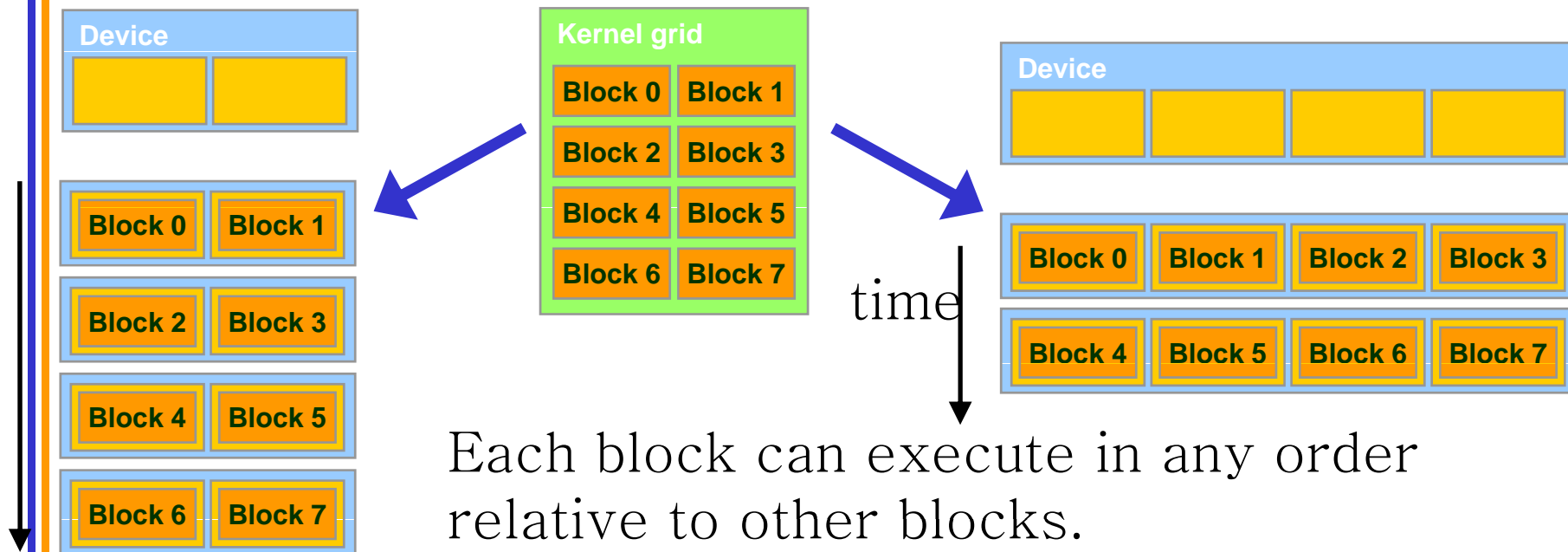

G80 Example: Executing Thread Blocks

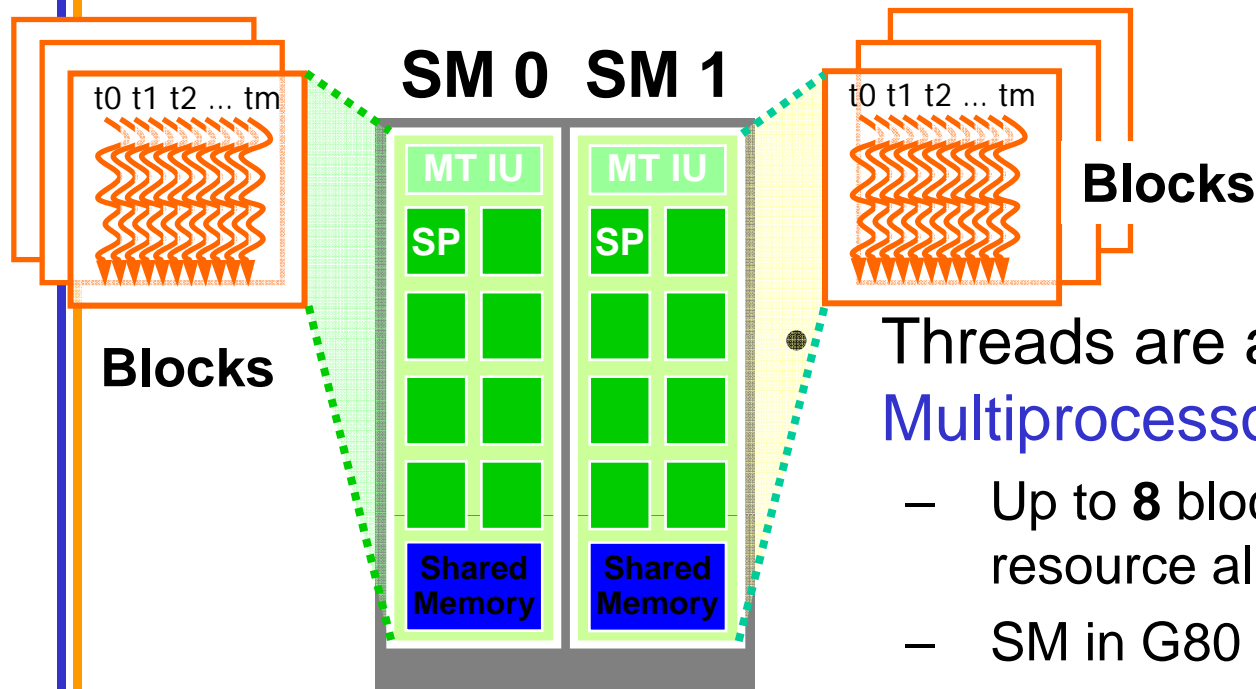

Threads are assigned to **Streaming Multiprocessors** in block granularity

- Up to **8** blocks to each SM as resource allows
- SM in G80 can take up to **768** threads
 - Could be 256 (threads/block) * 3 blocks
 - Or 128 (threads/block) * 6 blocks, etc.
- Threads run concurrently
 - SM maintains thread/block id #s
 - SM manages/schedules thread execution

G80 Example: Thread Scheduling

- Each Block is executed as 32-thread Warps
 - An implementation decision, not part of the CUDA programming model
 - Warps are scheduling units in SM
- If 3 blocks are assigned to an SM and each block has 256 threads, how many Warps are there in an SM?
 - Each Block is divided into $256/32 = 8$ Warps
 - There are $8 * 3 = 24$ Warps

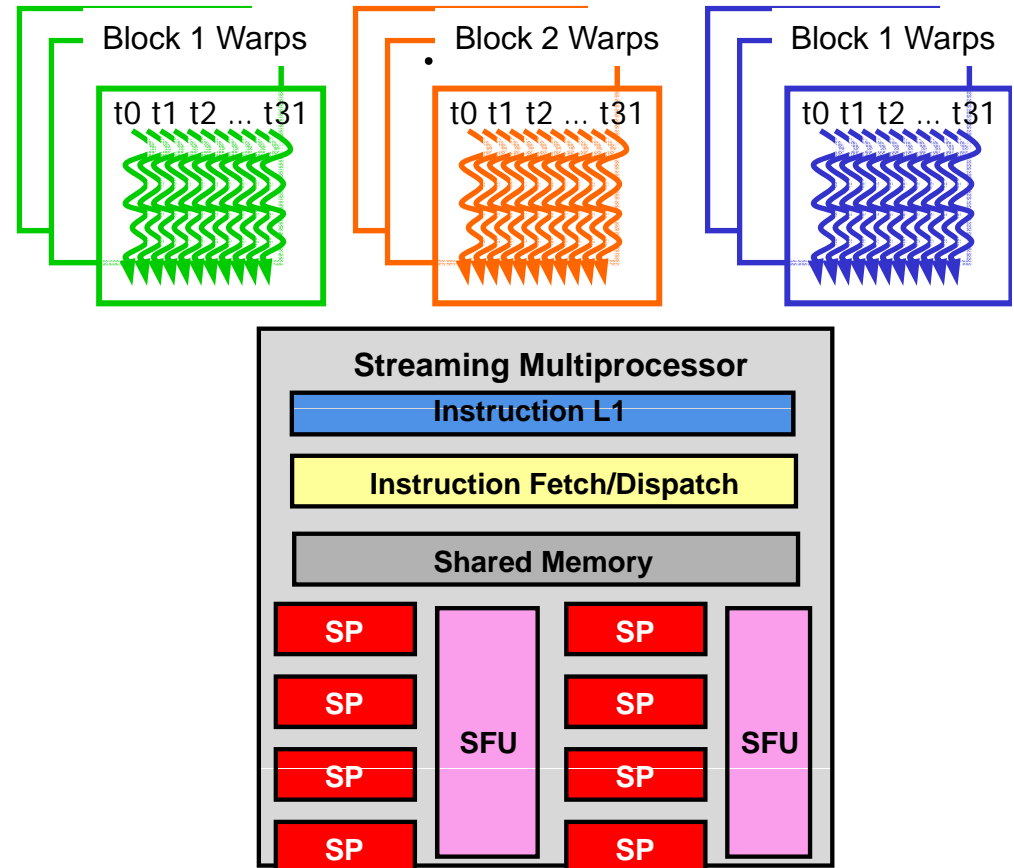

G80 Example: Thread Scheduling (Cont.)

- SM implements zero-overhead warp scheduling
 - At any time, only one of the warps is executed by SM
 - Warps whose next instruction has its operands ready for consumption are eligible for execution
 - Eligible Warps are selected for execution on a prioritized scheduling policy
 - All threads in a warp execute the same instruction when selected

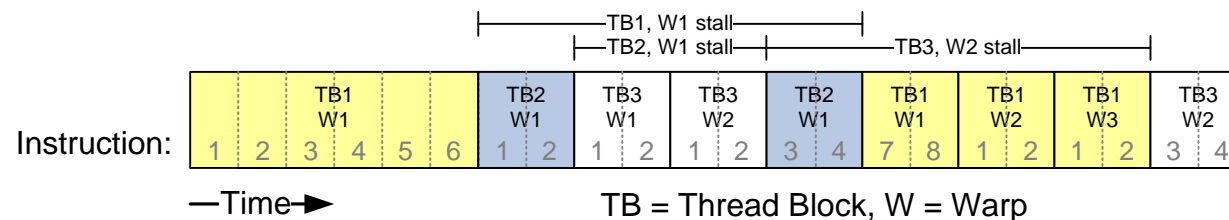

G80 Block Granularity Considerations

- For Matrix Multiplication using multiple blocks, should I use 8X8, 16X16 or 32X32 blocks?
 - For 8X8, we have 64 threads per Block. Since each SM can take up to 768 threads, there are 12 Blocks. However, each SM can only take up to 8 Blocks, only 512 threads will go into each SM!
 - For 16X16, we have 256 threads per Block. Since each SM can take up to 768 threads, it can take up to 3 Blocks and achieve full capacity unless other resource considerations overrule.
 - For 32X32, we have 1024 threads per Block. Not even one can fit into an SM!

A decorative graphic on the left side of the slide consisting of two vertical lines: a blue line on the left and an orange line on the right, both extending from the top to the bottom of the slide.

Some Additional API Features

Application Programming Interface

- The API is an **extension to the C programming language**
- It consists of:
 - **Language extensions**
 - To target portions of the code for execution on the device
 - **A runtime library split into:**
 - A **common component** providing built-in vector types and a subset of the C runtime library in both host and device codes
 - A **host component** to control and access one or more devices from the host
 - A **device component** providing device-specific functions

Language Extensions: Built-in Variables

- `dim3 gridDim;`
 - Dimensions of the grid in blocks (`gridDim.z` unused)
- `dim3 blockDim;`
 - Dimensions of the block in threads
- `dim3 blockIdx;`
 - Block index within the grid
- `dim3 threadIdx;`
 - Thread index within the block

Common Runtime Component: Mathematical Functions

- `pow, sqrt, cbrt, hypot`
- `exp, exp2, expm1`
- `log, log2, log10, log1p`
- `sin, cos, tan, asin, acos, atan, atan2`
- `sinh, cosh, tanh, asinh, acosh, atanh`
- `ceil, floor, trunc, round`
- Etc.
 - When executed on the host, a given function uses the C runtime implementation if available
 - These functions are only supported for scalar types, not vector types

Device Runtime Component: Mathematical Functions

- Some mathematical functions (e.g. `sin(x)`) have a less accurate, but faster device-only version (e.g. `__sin(x)`)
 - `__pow`
 - `__log`, `__log2`, `__log10`
 - `__exp`
 - `__sin`, `__cos`, `__tan`

Host Runtime Component

- Provides functions to deal with:
 - Device management (including multi-device systems)
 - Memory management
 - Error handling
- Initializes the first time a runtime function is called
- A host thread can invoke device code on only one device
 - Multiple host threads required to run on multiple devices

Device Runtime Component: Synchronization Function

- `void __syncthreads() ;`
- Synchronizes all threads in a block
- Once all threads have reached this point, execution resumes normally
- Used to avoid RAW / WAR / WAW hazards when accessing shared or global memory
- Allowed in conditional constructs only if the conditional is uniform across the entire thread block