

**2014 Spring**

**“Advanced Physical Metallurgy”  
- Bulk Metallic Glasses-**

**03.04.2014**

**Eun Soo Park**

**Office: 33-313**

**Telephone: 880-7221**

**Email: [espark@snu.ac.kr](mailto:espark@snu.ac.kr)**

**Office hours: by appointment**

# ***Introduction***

- **Web lecture assistance: <http://etl.snu.ac.kr>**
  - **All materials will be posted at the webpage.**
  - **text message will be sent for the important and urgent notice.**
- **Hand out copied materials or scanned materials in website**

**Text: “Bulk Metallic Glasses”, C. Suryanarayana, A. Inoue,  
CRC Press, Taylor & Francis Group (2011)**

- References: 1) "Metallic Glasses", P. Duwez et al.  
American Society for Metals, Metals Park, Ohio (1976)
- 2) “Amorphous Metallic Alloys”, F.E. LUBORSKY  
Butterworths & Co. (Publishers) Ltd. (1983)
- 3) "Bulk Metallic Glasses", M.K. Miller, P.K. Liaw,  
Springer (2008)

Additional reading materials will be provided.

# Course Goals

This course will cover the **rapidly evolving field of amorphous materials**, with a particular emphasis on the connection among thermodynamic, kinetic, and structural aspects of amorphous materials. This course intends to illustrate the major materials issues for **amorphous metals, from processing to properties and from the fundamental science of glasses to viable industrial applications.** I hope that this course shows why amorphous materials are attracting such an intensive interest and serve to highlight some challenging issues awaiting resolution. After completing this course, students performing experimental research using amorphous materials should be reasonably informed about materials preparation, processing, and stability. Students performing research outside this field should **be able to consider amorphous materials as a new form of material suitable for selection in their innovations.**

# ***Schedule***

week 1 Introduction to Amorphous materials

week 2 Classification of Solids

week 3 Definition of Amorphous Materials

week 4 Preparation of Amorphous Materials

week 5 Phase Transition: glass transition

week 6 Measurement of Glass Transition Temperature

week 7 Theories for the Glass Transition I: thermodynamic / entropy

week 8 Theories for the Glass Transition II: relaxation behavior / viscosity

week 9 Structural Approach to Glass Formation

week 10 Kinetic Approach to Glass Formation

week 11 Ease of Glass Transition: glass-forming ability

week 12 Glass Forming Ability Parameters

week 13 Formation of Bulk Metallic Glasses

week 14 Mechanical Properties of Bulk Metallic Glasses and Their Composites

week 15 Unique Properties of of Bulk Metallic Glasses

week 16 Potential Applications of Bulk Metallic Glasses

# ***Components of Your Grade:***

## **1) Exams (mid: 35% + final: 40%)**

**There will be two exams, each of which takes place in class for 3 hours. The exams will be conceptual and simple.**

## **2) Reports and Presentation (15%) (+Incentive Homework 5%)**

**There will be one presentation on the topics of amorphous materials in the last part of course, which takes place in class for half an hour. The presentation will include mainly topics of amorphous materials from the fundamental science to viable industrial applications.**

## **3) Attendance (10%)**

**Please don't be late to class.**

**REMARK: The grade components might change up to 5% depending on the student's achievement.**

# The 3<sup>rd</sup> Revolution in Materials

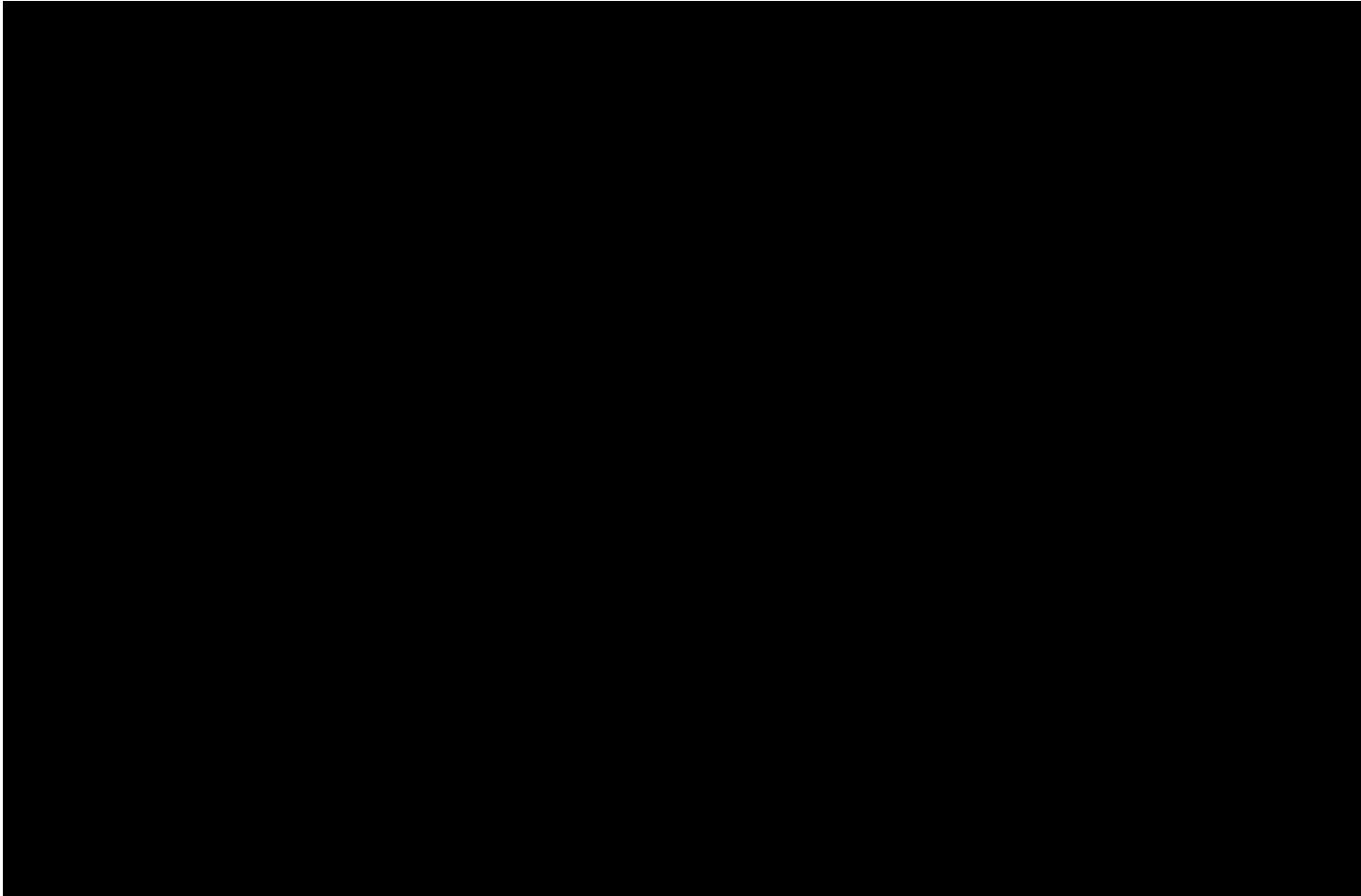

# Structure of crystals, liquids and glasses

## Crystals

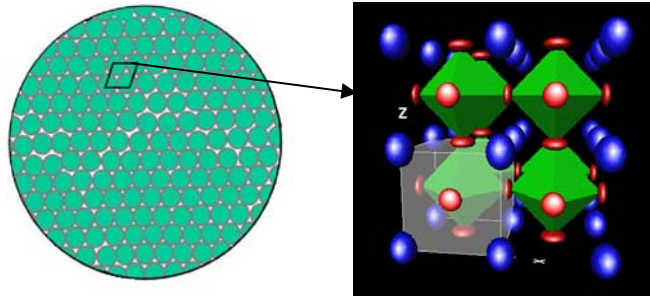
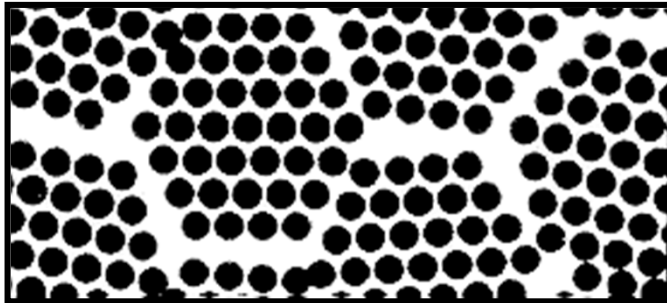

- periodic
- grain boundaries

## Liquids, glasses

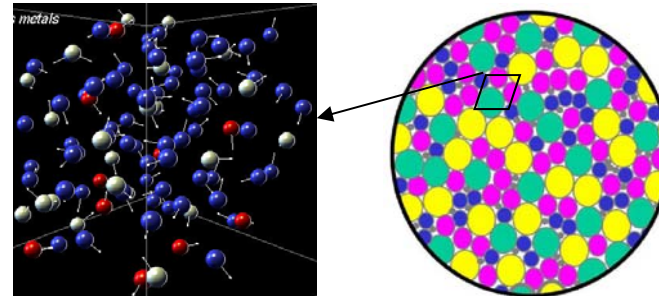
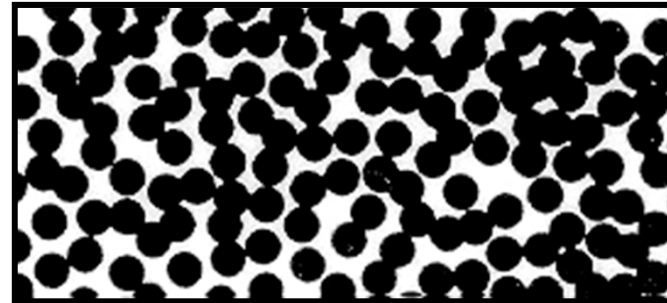

- amorphous = non-periodic
- no grain boundaries

# Time-Temperature-Transformation diagram

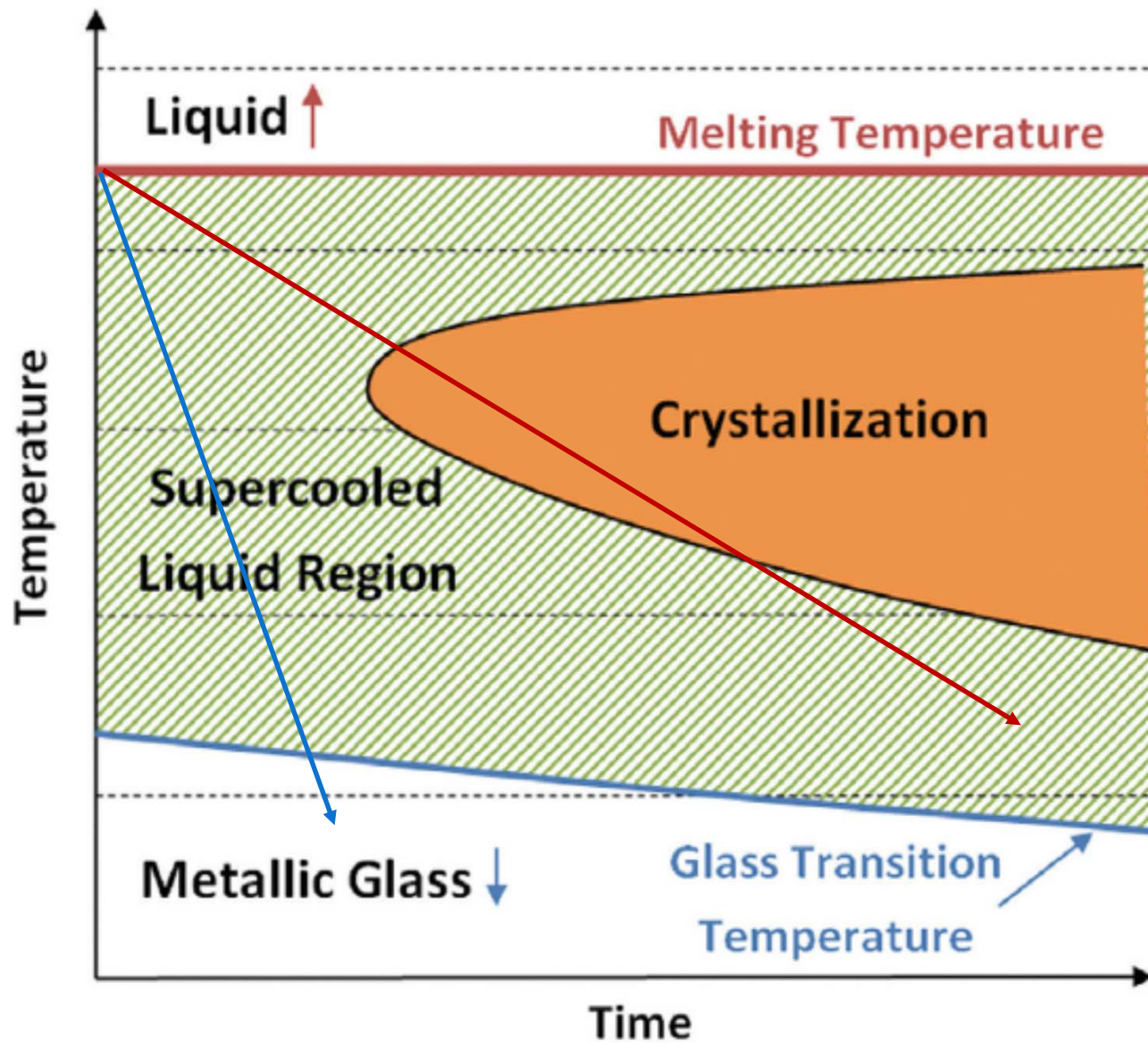



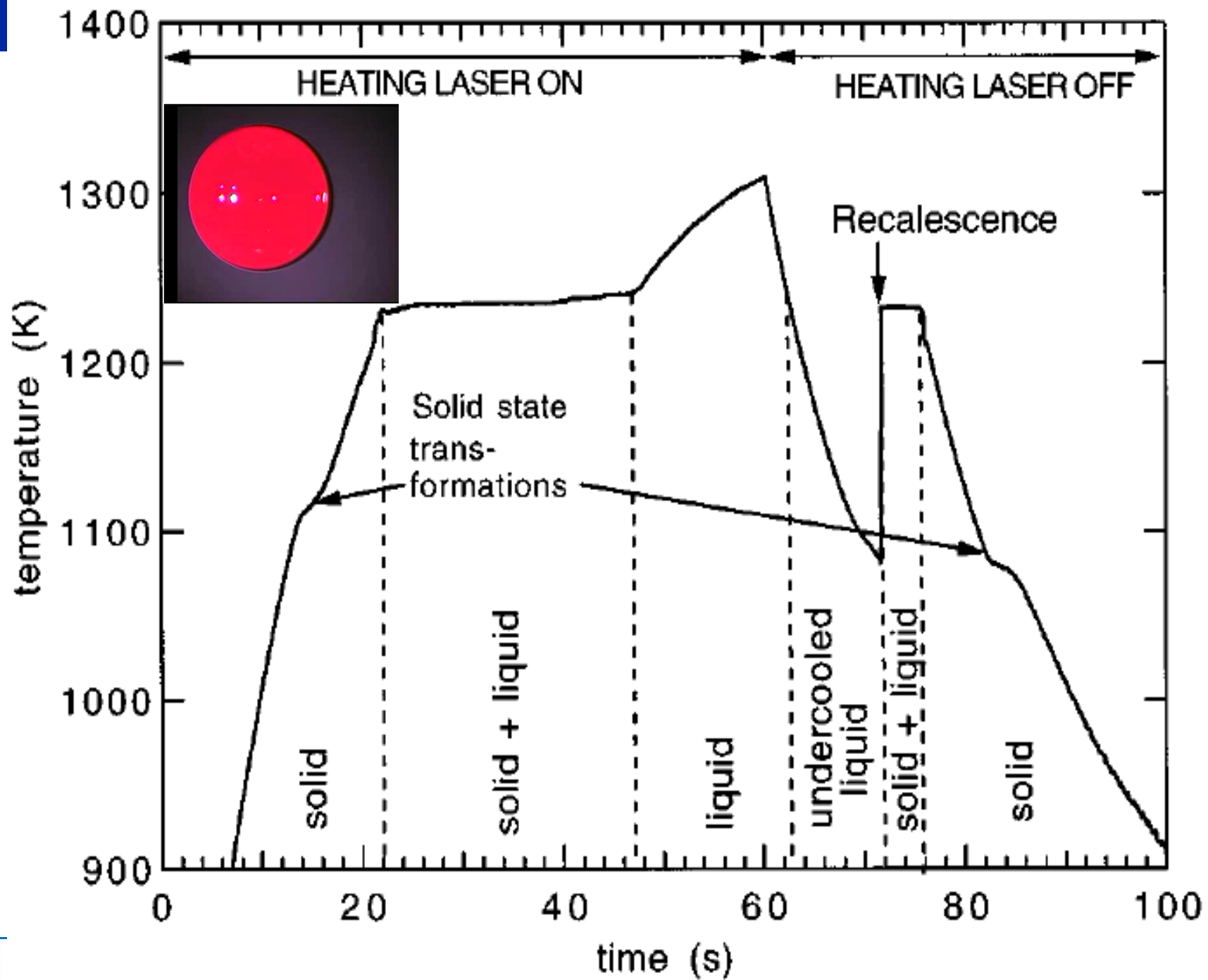

# Electrostatic Levitation: cooling curve of Vitreloy 1 system

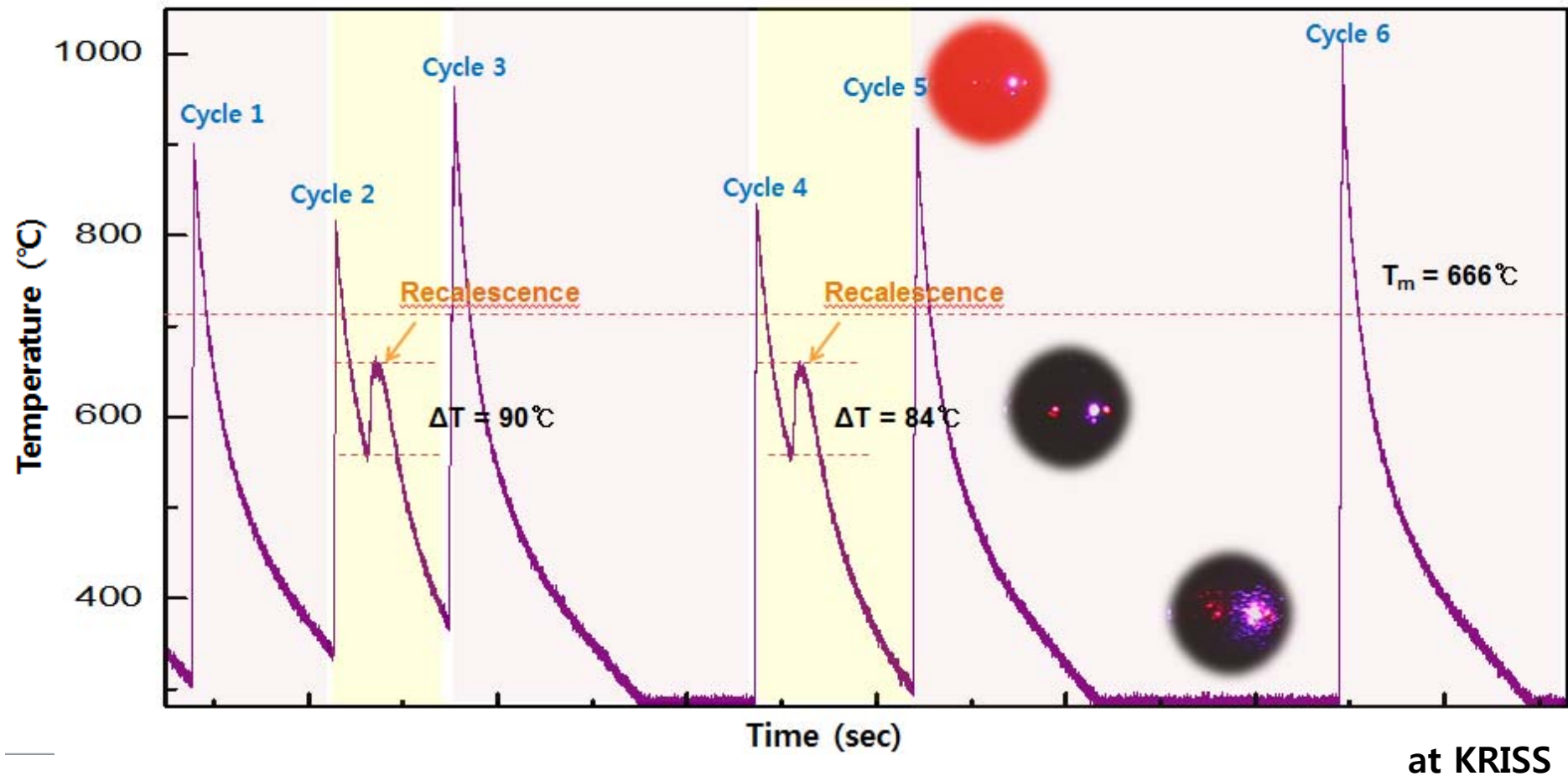

# Amorphous Materials

- **Amorphous materials**

a wide diversity of materials can be rendered amorphous indeed **almost all materials can.**

- metal, ceramic, polymer
- **glassy/non-crystalline material**

*cf*) amorphous vs glass

- random atomic structure (short range order)
- showing glass transition.

- retain liquid structure
- rapid solidification from liquid state

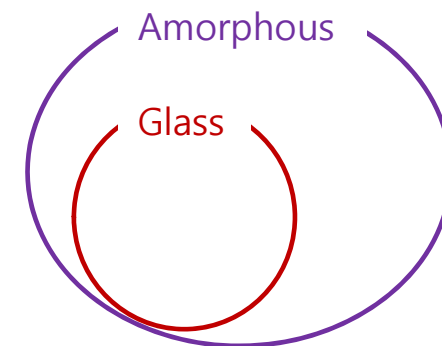

Glassmaking by humans can be traced back to 3500 BCE in Mesopotamia (current Iraq).

**Obsidian** is a naturally occurring volcanic glass formed as an extrusive igneous rock. It is produced when felsic lava extruded from a volcano **cools rapidly with minimum crystal growth**. Obsidian is commonly found within the margins of rhyolitic lava flows known as **obsidian flows**, where the chemical composition (high silica content) induces a high viscosity and polymerization degree of the lava. The inhibition of atomic diffusion through this **highly viscous and polymerized lava** explains the lack of crystal growth. Because of this lack of crystal structure, obsidian blade edges can reach almost molecular thinness, leading to its ancient use as projectile points and blades, and its modern use as surgical scalpel blades.



# First Amorphous Metals: evaporation method

## *Über nichtleitende Metallmodifikationen<sup>1)</sup>*

*Von Johannes Kramer*

(Mit 8 Figuren)

Das metallische Leitvermögen wird bekanntlich auf das Vorhandensein freibeweglicher Elektronen und damit auch ortsgebundener positiver Ionen zurückgeführt. Da nun ein nichtionisierter Metaldampf ein vollkommener Nichtleiter ist, so liegt die Vermutung nahe, daß es bei Kondensation eines solchen Dampfes gelingen müßte, nichtleitende Schichten zu erhalten, wenn Wechselwirkungen zwischen den regellos aufeinandergepackten Atomen vermieden werden könnten. Man hätte es dann mit einem Gebilde zu tun, das als völlig amorph anzusehen wäre und in seiner Konstitution am ehesten einem hochkomprimierten Gase entspräche.

J. Kramer  
Nonconducting  
modifications of metals.  
Ann. Physik (Berlin,  
Germany) 19, 37 (1934)

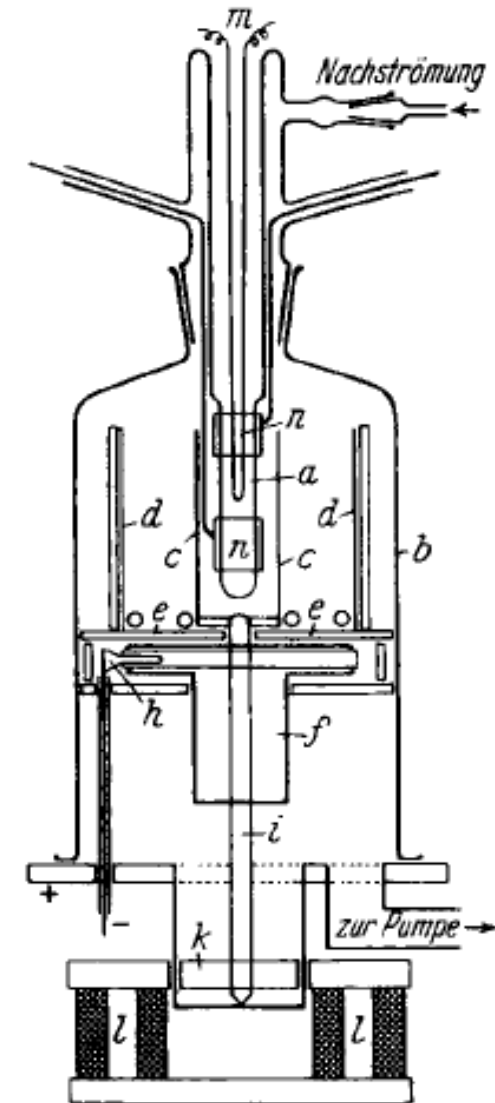
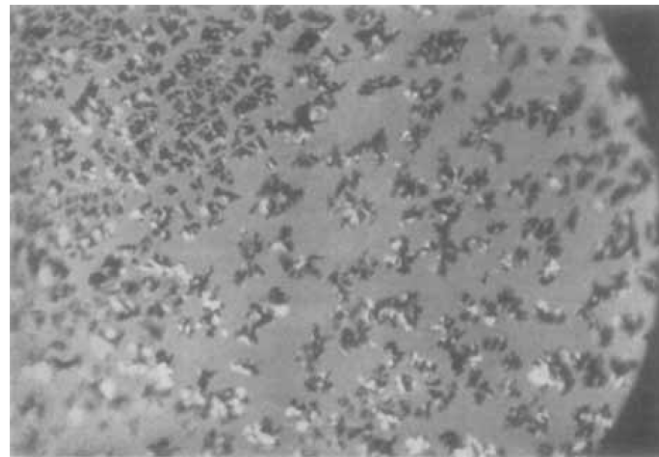
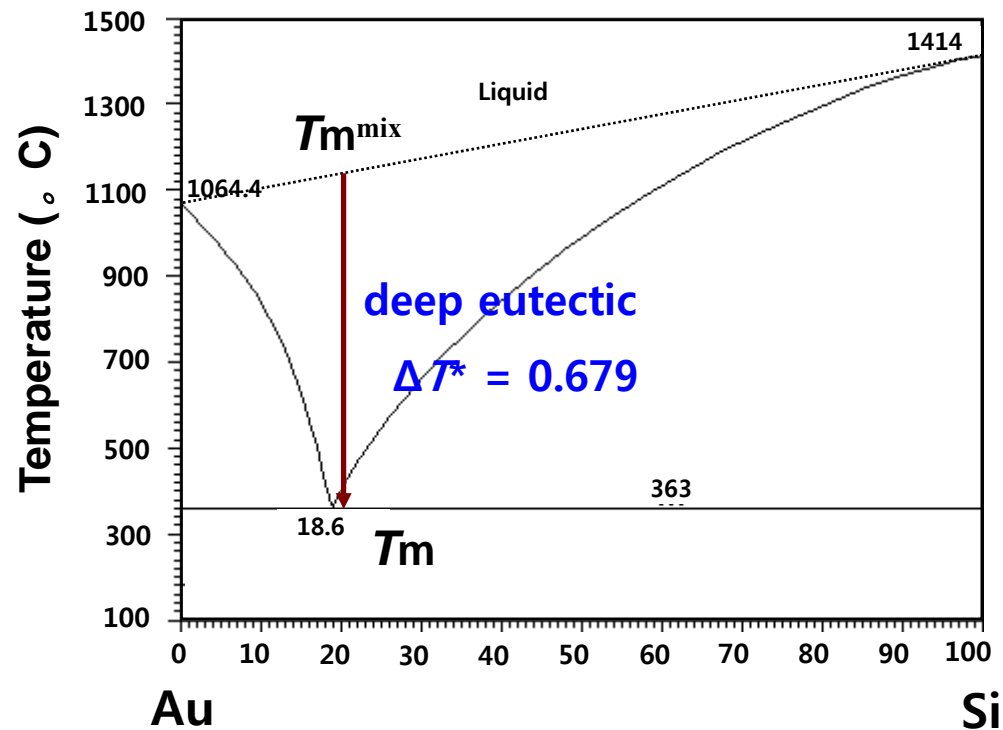

Fig. 1.  
Zerstäubungsapparatur

# Glass formation : stabilizing the liquid phase

- ▶ First **metallic glass** ( $\text{Au}_{80}\text{Si}_{20}$ ) produced by splat quenching at Caltech by Pol Duwez in 1960.



*W. Klement, R.H. Willens, P. Duwez, Nature 1960; 187: 869.*

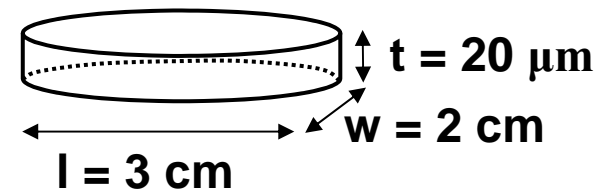
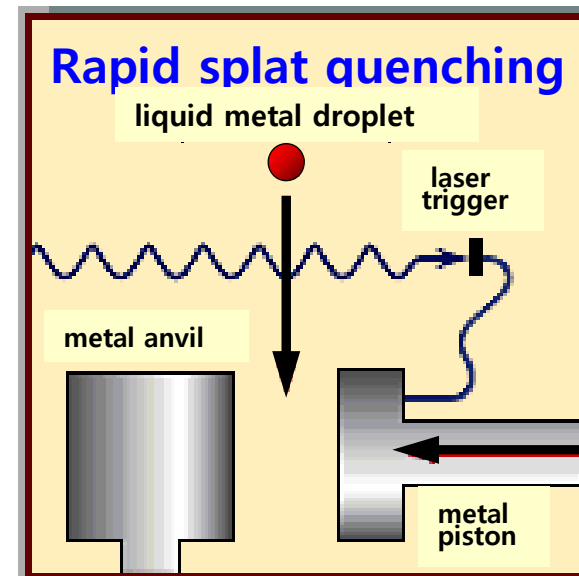

# Glass formation : Rapid quenching of liquid phase

- ▶ 1969 Ribbon type with long length using melt spinner : FePC, FeNiPB alloy



# Bulk formation of metallic glass

- ▶ First bulk metallic glass:  $\text{Pd}_{77.5}\text{Cu}_6\text{Si}_{16.5}$  ( $T_{rg}=0.64$ )

By droplet quenching (CR~800 K/s)

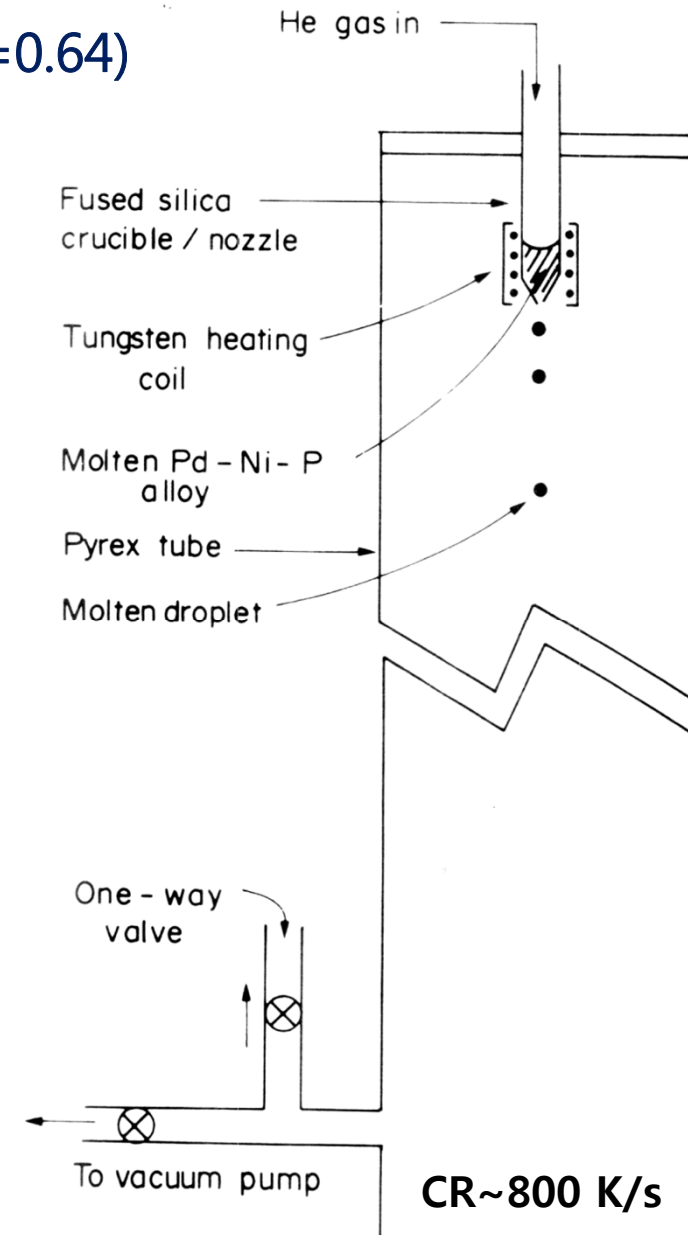
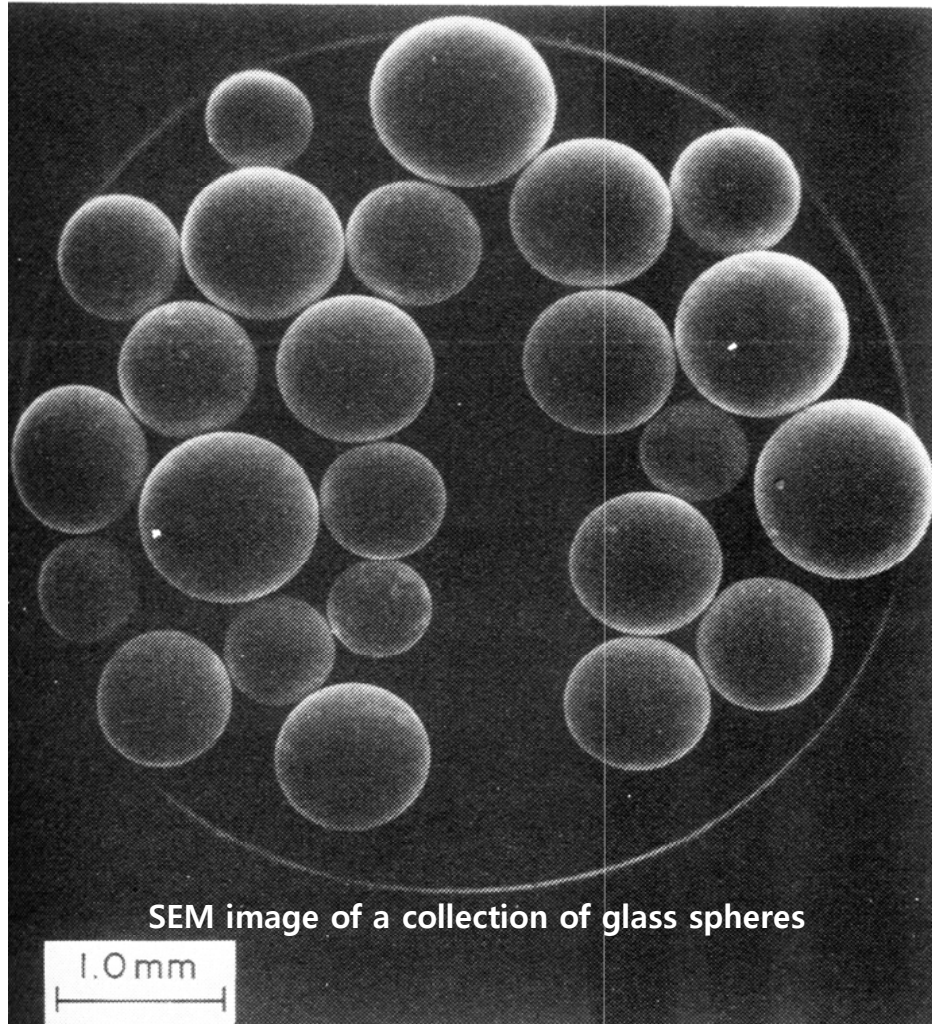



# Bulk formation of metallic glass

- ▶ First bulk metallic glass  
 $\text{Pd}_{77.5}\text{Cu}_6\text{Si}_{16.5}$  ( $T_{rg}=0.64$ )



- ▶ Alloy Selection: consideration of  $T_{rg}$   
 $\text{Pd}_{40}\text{Ni}_{40}\text{P}_{20}$  ( $T_{rg}=0.67$ )

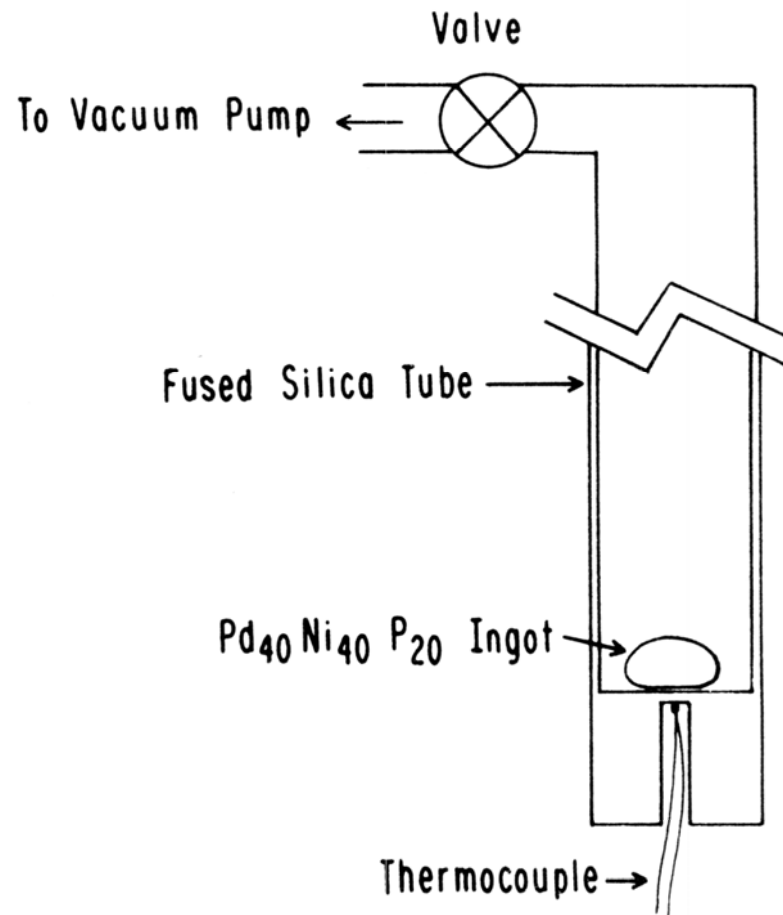

<Schematic diagram of apparatus>

Suppression of heterogeneous nucleation

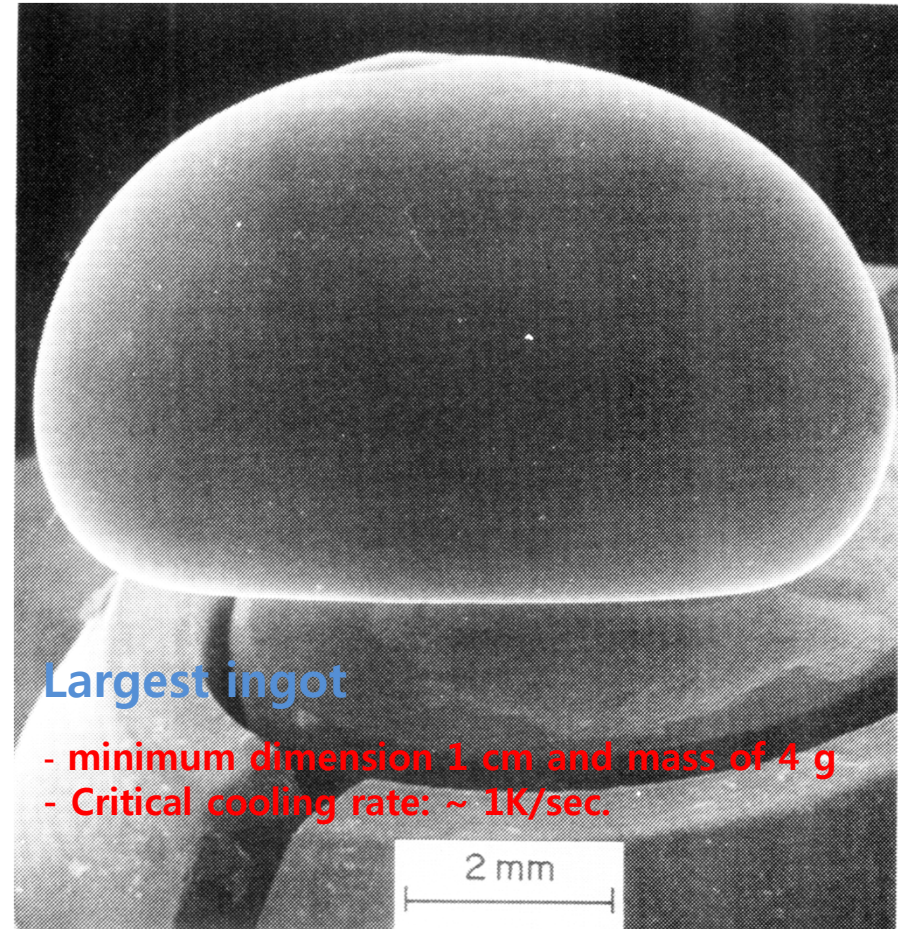

Largest ingot

- minimum dimension 1 cm and mass of 4 g
- Critical cooling rate: ~ 1K/sec.

# Recent BMGs with critical size $\geq 10$ mm

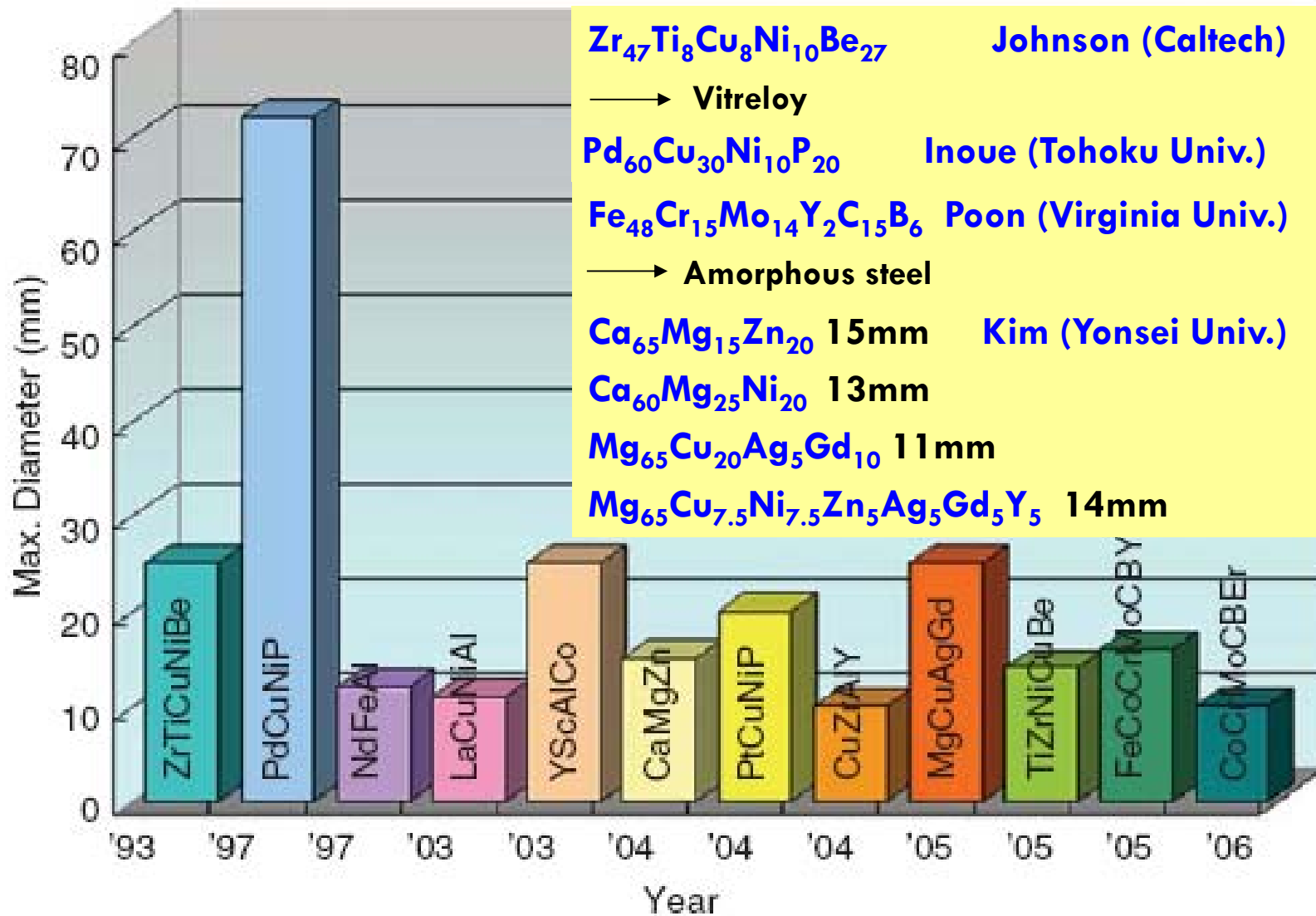

# Bulk glass formation in the Pd-/Ni-/Cu-/Zr- element system

## Massy Ingot Shape

(a) Pd-Cu-Ni-P

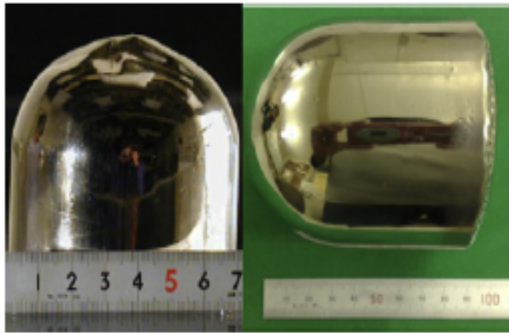

72 $\phi$ x 75 mm 80 $\phi$ x 85 mm

(b) Zr-Al-Ni-Cu

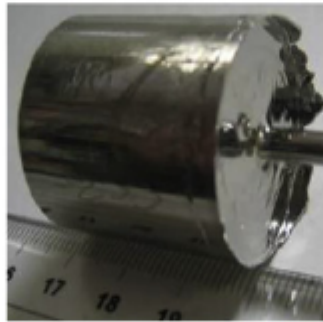

(c) Cu-Zr-Al-Ag

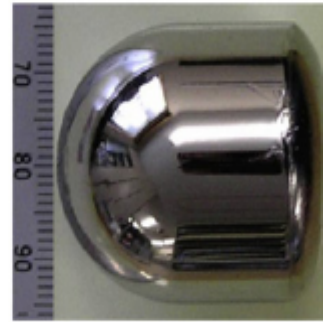

(d) Ni-Pd-P-B

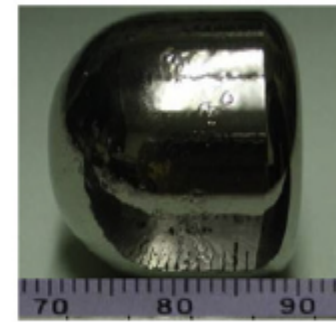

## Cylindrical Rods

(e) Pd-Cu-Ni-P

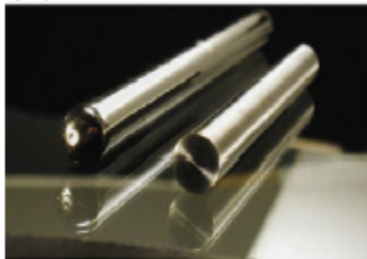

(f) Pt-Pd-Cu-P

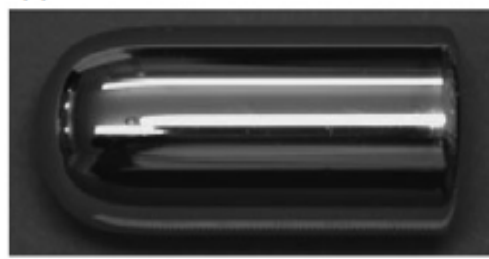

## Hollow Pipes

(g) Pd-Cu-Ni-P

