

CH. 3
FORCES AND MOMENTS
TRANSMITTED BY SLENDER
MEMBERS

3.1 Introduction

→ In this and the following two chapters we shall reexamine the significance of the separate steps of (2.1) in order to lay a more secure foundation for our subsequent study of complete problems which again require the simultaneous consideration of all three steps. In this chapter we shall be concerned only with step 1, the study of forces and the equilibrium requirements, as applied to slender members.

cf. Steps of (2.1)

- i) Study of forces and equilibrium requirements
- ii) Study of deformation and conditions of geometric fit
- iii) Application of force-deformation relations

► Definition of slender members

→ We shall note that a large portion of the load-carrying members can be classified as slender members. By a slender member we mean any part whose length is much greater (say at least five times greater) than either of its cross-sectional dimensions.

cf. This classification includes such things as beams, columns, shafts, rods, stringers, struts, and links. Even if a long, thin rod is formed into a hoop or a coil spring whose diameter is large compared with the thickness of the rod, it still retains its identity as a slender member

3.2 General Method

► Definition of the direction of force vector in 3-D

$$F_{xy}$$

- i) The former, x, is the direction of the area vector which is perpendicular to the area.
- ii) The latter, y, is the direction of the force or moment vector.
- iii) F_{xy} means that y direction force is applied on y-z plane.

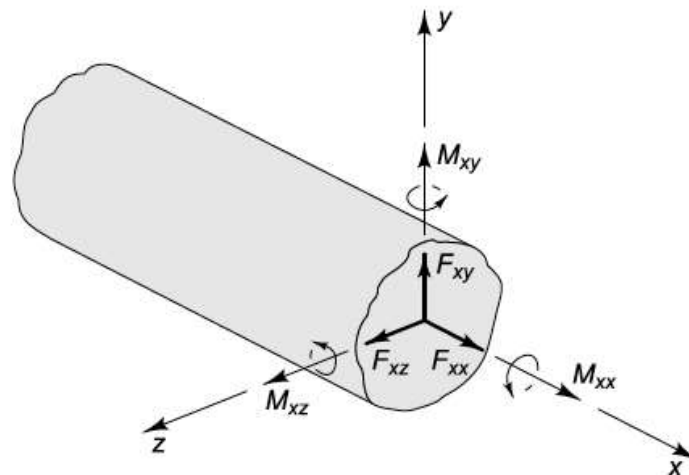

Fig. 3.1 Forces and moments acting on a section of a member

F_{xx} *Axial force.* This component tends to elongate the member and is often given the symbol F or F_x . We discussed such forces in Chaps. 1 and 2.

F_{xy}, F_{xz} *Shear force.* These components tend to shear one part of the member relative to the adjacent part and are often given the symbols V , or V_y and V_z .

M_{xx} *Twisting moment.* This component is responsible for the twisting of the member about its axis and is often given the symbol M_t or M_{tx} .

M_{xy}, M_{xz} *Bending moments.* These components cause the member to bend and are often given the symbols M_b , or M_{by} and M_{bz} .

► Sign convention for consistency and reproducibility of analyses

- i) Positive when the force or moment component acts on a positive face in a positive coordinate direction. The force and moment components shown in Fig. 3.1 all are positive according to this convention.
- ii) Positive when the force or moment component acts on a negative face in a negative coordinate direction.

For 2-D case (say, the xy plane), the only three components remain: the axial force (F), the shear force (V), and the bending moment (M_b)

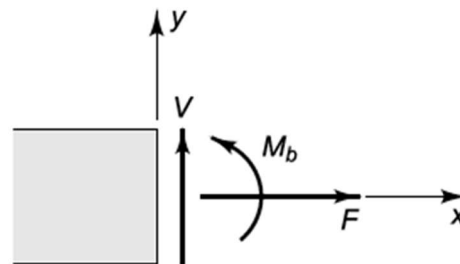

Fig. 3.3 Force and moment components in two dimensions

► The steps involved in solving for the forces and moments in a slender member

- i) **Idealization:** Idealize the actual problem, i.e., create a model of the system, and isolate the main structure, showing all forces acting on the structure.
- ii) **Determining external forces or moments:** Using the equations of equilibrium ($\sum \mathbf{F} = 0$ and $\sum \mathbf{M} = 0$), calculate any unknown external or support forces.
- iii) **Determining internal forces or moments:** Cut the member at a section of interest, isolate one of the segments, and repeat step 2 on that segment.

► Example 3.1 As an example, let us consider a beam supporting a weight near the center and resting on two other beams, as shown in Fig. 3.4 (a). It is desired to find the forces and moments acting at section C.

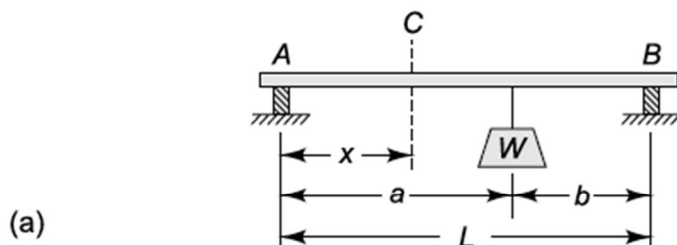

Fig. 3.4 Example 3.1. Calculation of shear force and bending moment at a section of a beam

▷ Assumption

- i) If the beam is not completely rigid, it will tend to bend slightly, as in Fig. 3.4 (b). When the coefficient of friction is small, we can be satisfied that the friction forces will be small compared with the normal forces. On the basis of these considerations we idealize the system in Fig 3.4 (c), where we have shown vertical reactions at A and B.
- ii) In Fig. 3 4 (c) we have also neglected the weight of the beam

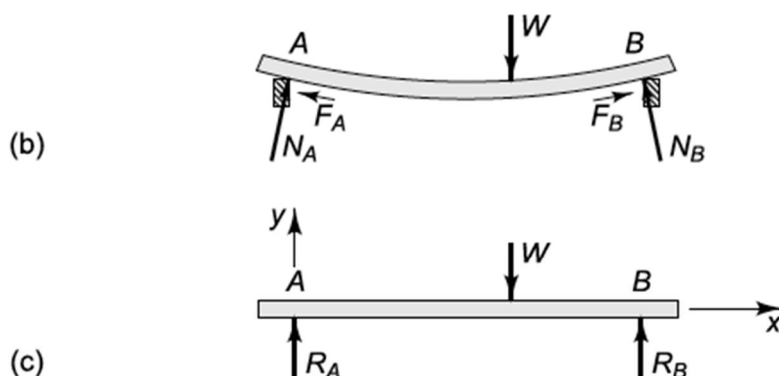

Fig. 3.4 Example 3.1. Calculation of shear force and bending moment at a section of a beam

▷ Equilibrium

$$\sum F_y = 0; \quad R_A + R_B = W \quad (\text{a})$$

$$\sum M_A = 0; \quad R_B L = W a \quad (\text{b})$$

→ Although it is not difficult to solve (a) and (b) simultaneously for R_A and R_B , we may note that it is often possible to avoid simultaneous equations by using alternative forms of the equilibrium requirements

$$\sum M_B = W b - R_A L = 0 \quad (\text{c})$$

$$\therefore R_A = \frac{Wb}{L}, \quad R_B = \frac{Wa}{L}$$

▷ F.B.D.

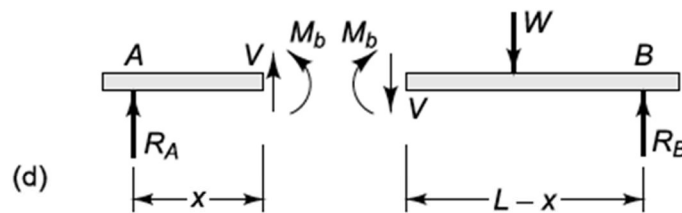

Fig. 3.4 Example 3.1. Calculation of shear force and bending moment at a section of a beam

▷ Equilibrium

$$\sum F_y = 0; \quad V + R_A = 0;$$

$$\therefore V = -R_A = -\frac{Wb}{L}$$

$$\sum M_A = 0; \quad M_b + Vx = 0$$

$$\therefore M_b = R_A x = \frac{Wb}{L} x$$

► Diagrams for shear force and bending moment

i) Shear-force diagram (S.F.D)

→ A graph which shows shear force plotted against distance along a beam

ii) Bending-moment diagram (B.M.D)

→ A similar graph showing bending moment as a function of distance

cf. Axial-force diagrams and twisting-moment diagrams are also employed in discussing slender members

► Example 3.2. It is desired to obtain the shear-force and bending-moment diagrams for the idealized beam of Fig 3.4 (c) which is redrawn in Fig 3.5 (a).

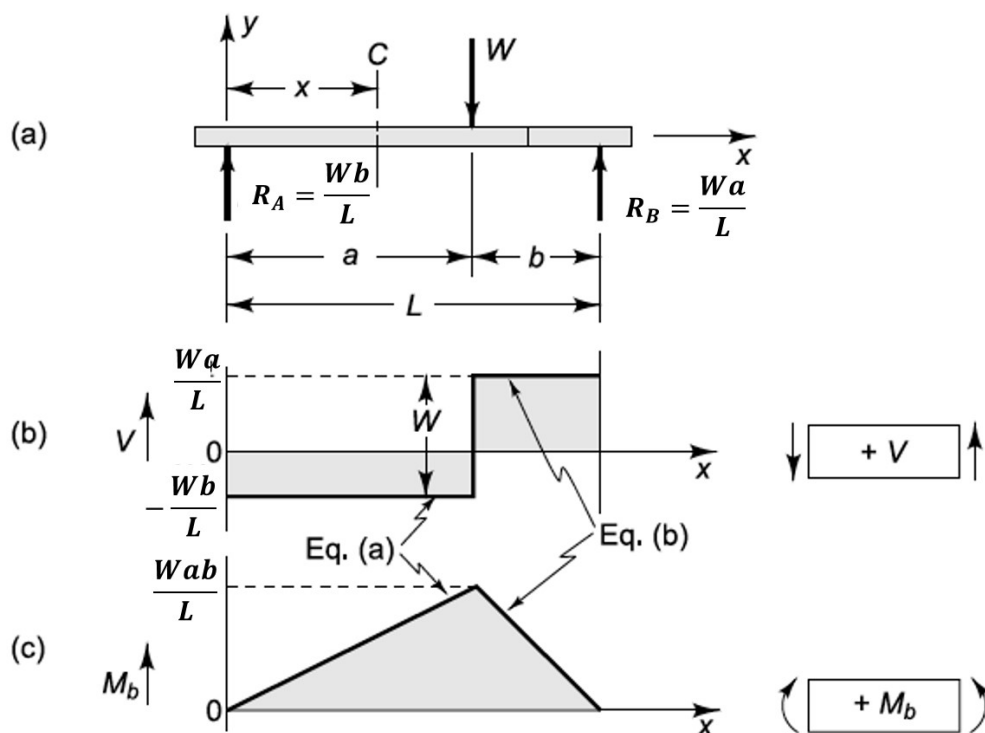

Fig. 3.5 Example 3.2. Shear-force and bending-moment diagrams for beam of Fig. 3.4(c)

1) For $0 < x < a$

F.B.D are in Fig. 3.4 (d) and in Example 3.1 we obtained the values

$$\begin{aligned} V &= -\frac{Wb}{L} \\ M_b &= \frac{Wb}{L}x \end{aligned} \quad (a)$$

We can thus consider Eqs. (a) to define the shear-force and bending-moment diagrams in the range $0 < x < a$.

2) For $a < x < L$

▷ F.B.D.

In Fig. 3.6~

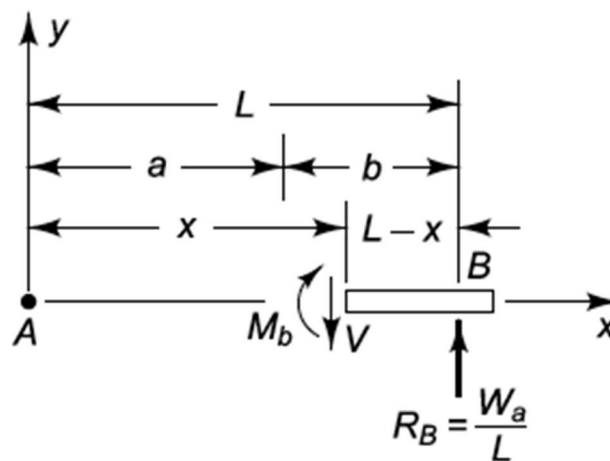

Fig. 3.6

Example 3.2. Free-body diagram for computing V and M_b when $a < x < L$

▷ Equilibrium

$$-V + R_B = 0;$$

$$\therefore V = R_B = \frac{Wa}{L}$$

$$-M_B + V(L - x) = 0;$$

$$\therefore M_B = R_B(L - x) = \frac{Wa}{L}(L - x)$$

3.3 Distributed Load

In the previous section it was assumed that the load acting on the slender member and the support forces were concentrated or “point” forces. Another idealization which is commonly employed is the concept of a continuously distributed loading.

► Intensity of Loading “q”

$$q = \lim_{\Delta x \rightarrow 0} \Delta F / \Delta x \quad (3.1)$$

→ Such forces might arise from fluid or gas pressures, or from magnetic or gravitational attractions.

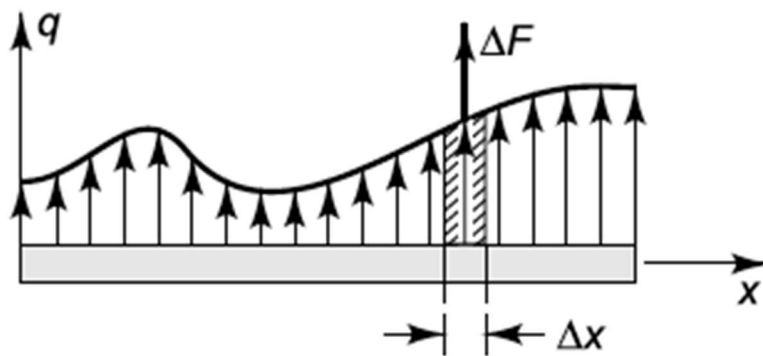

Fig. 3.7

Distributed load of intensity q

cf. The most common distributions in engineering work

i) Uniform Distribution → $q(x) = \text{constant}$

ii) Linearly Varying Distribution → $q(x) = Ax + B$

► Example 3.3 Consider the cantilever beam AB, built in at the right end, shown in Fig. 3.9 (a). Bricks having a total weight W have been piled up in triangular fashion. It is desired to obtain shear-force and bending-moment diagrams.

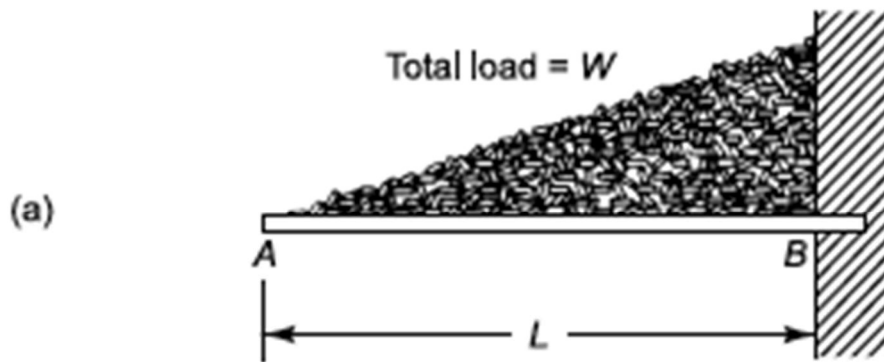

Fig. 3.9 Example 3.3. Distributed load handled by integration

▷ Assumption

→ In Fig. 3.9 (b) the loading has been idealized as a continuous linearly varying distribution of intensity $q = -w = -w_0x/L$.

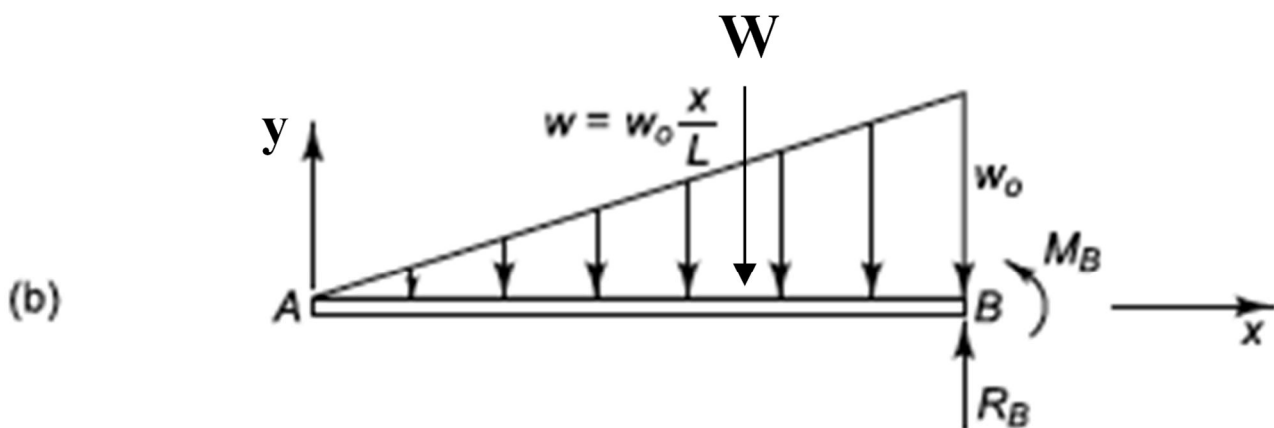

Fig. 3.9 Example 3.3. Distributed load handled by integration

▷ Equilibrium (see Fig. 3.9 (c))

$$1) \sum F_y = 0$$

$$-W + R_B = 0$$

$$R_B = W = \int_0^L w dx \quad (a)$$

$$\rightarrow R_B = \int_0^L w_0 x/L dx = w_0 L/2 \quad (b)$$

$$(cf. \quad w_0 = 2W/L) \quad (c)$$

$$2) \sum M_B = 0$$

for $\Delta x \rightarrow 0$;

$$\int_0^L w(L-x)dx + M_B = 0 \quad (d)$$

$$\begin{aligned} \rightarrow -M_B &= \int_0^L \frac{w_0 x}{L} (L-x) dx \\ &= \frac{w_0}{L} \left(\frac{L^3}{2} - \frac{L^3}{3} \right) = \frac{WL}{3} \end{aligned} \quad (e)$$

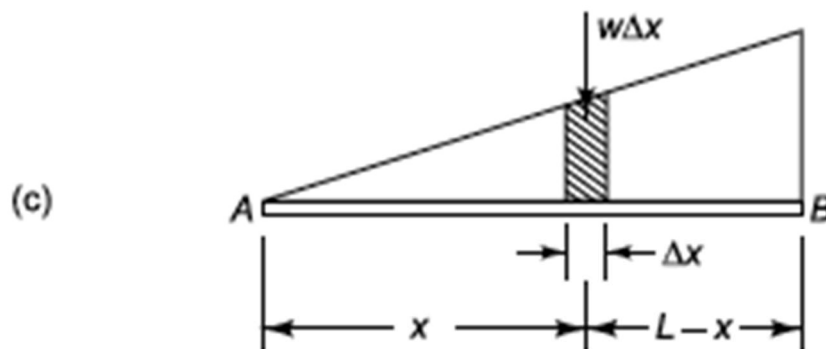

Fig. 3.9 Example 3.3. Distributed load handled by integration

▷ Equilibrium (see Fig. 3.9 (d))

→ In here, the variable ξ is introduced as a dummy variable in the integration to avoid confusion with x .

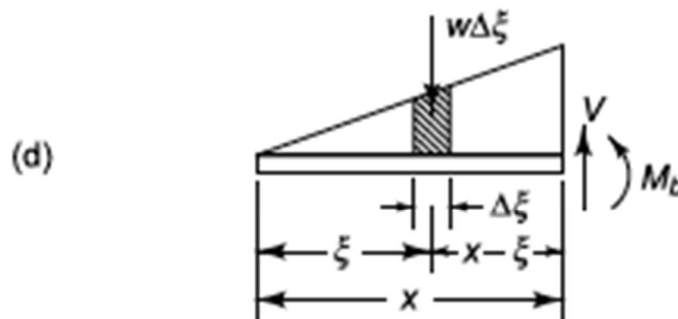

Fig. 3.9 Example 3.3. Distributed load handled by integration

$$1) \sum F_y = 0$$

$$V = \int_0^x w d\xi = w_0 \frac{x^2}{2L} \quad (f)$$

$$2) \sum M_B = 0$$

$$\begin{aligned} M_b &= - \int_0^x w(x - \xi) d\xi = 0 \\ &= -w_0 \frac{x^3}{6L} \end{aligned} \quad (g)$$

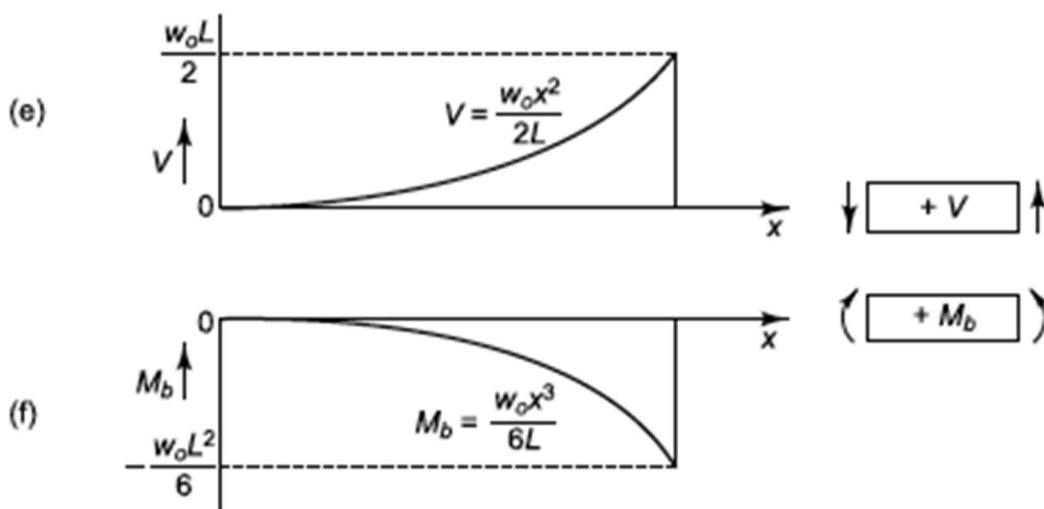

Fig. 3.9 Example 3.3. Distributed load handled by integration

3.4 Resultant of Distributed Load

→ Two systems of forces are said to be statically equivalent if it takes the same set of additional forces to reduce each system to equilibrium.

► Resultant

A single force which is statically equivalent to a distribution of forces is called the resultant of the distributed force system.

→ This is permissible only when we are evaluating external reactions on the member; it is not allowable when calculating internal forces and moments.

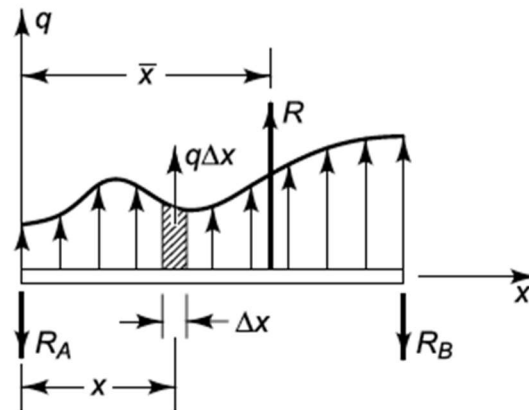

Fig. 3.11 The resultant R of distributed loading $q(x)$

▷ The magnitude of its resultant R and its location \bar{x}

$$1) \sum F_y = 0; \quad \int_0^L q dx - R_A - R_B = 0$$

$$\rightarrow R - R_A - R_B = 0$$

$$2) \sum M_A = 0; \quad \int_0^L x(q dx) - R_B L = 0$$

$$\rightarrow R\bar{x} - R_B L = 0$$

$$\therefore R = \int_0^L q dx, \quad \bar{x} = \int_0^L x q dx / R \quad (3.2)$$

cf. The centroid of an area in the x - y plane has the coordinates

$$\bar{x} = \int x dA / \int dA, \quad \bar{y} = \int y dA / \int dA \quad (3.3)$$

cf. The centroid of a volume has the coordinates

$$\bar{x} = \int x dV / \int dV, \quad \bar{y} = \int y dV / \int dV, \quad \bar{z} = \int z dV / \int dV \quad (3.4)$$

► Example 3.4 Figure 3. 12 (a), which is the same as Fig. 3.9 (b), shows the free-body diagram of the cantilever beam AB with a linearly varying distributed load. In Fig. 3. 12 (b) the distributed

load has been replaced by a single resultant R at the location \bar{x} . Since the loading diagram is a triangle, its area is half the product of base times altitude, and its centroid is two-thirds the distance from vertex to midpoint of opposite side.

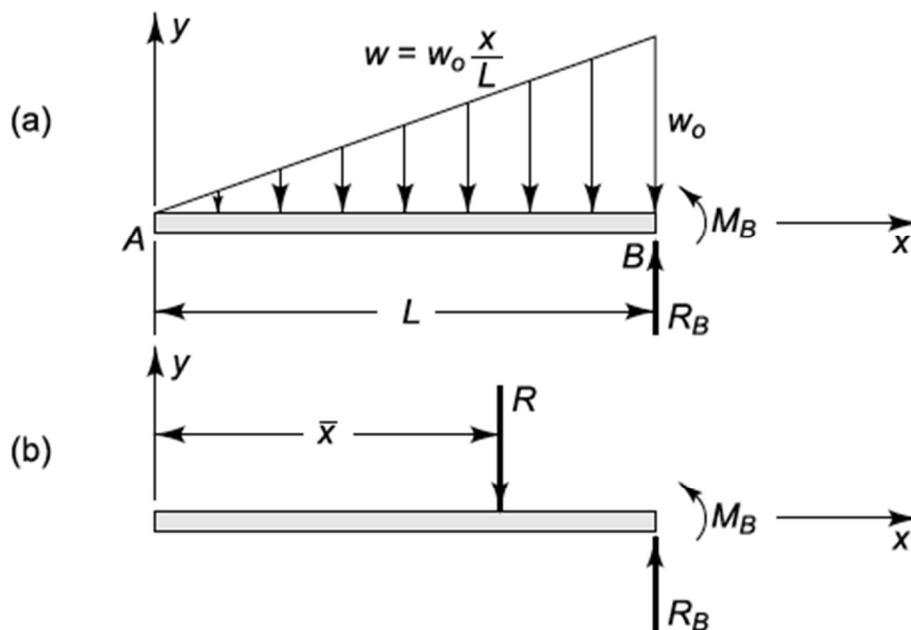

Fig. 3.12 Example 3.4. A distributed loading is replaced by its resultant

$$\begin{aligned}
 R &= w_0 L / 2 \\
 \bar{x} &= 2L / 3
 \end{aligned}
 \tag{a}$$

$$\begin{aligned}
 \sum F_y &= R_B - R = 0; \\
 R_B &= w_0 L / 2
 \end{aligned}
 \tag{b}$$

$$\begin{aligned}
 \sum M_B &= R(L - \bar{x}) + M_B = 0; \\
 M_B &= -w_0 L^2 / 6
 \end{aligned}
 \tag{c}$$

It is not permissible to use the above resultant R to calculate shear force and bending moments “within” the beams.

We can, however, “section” the beam at an arbitrary point x , as in Fig. 3.13 (a), and then the shear force and bending moment at the section become external forces for the isolated beam element of Fig. 3.13 (b).

We may replace the distributed force acting on the portion of the beam, shown in Fig. 3.13 (b), by its resultant R' .

$$\begin{aligned}
 V &= R' = (w_0 x/L) \cdot x/2 = w_0 x^2/(2L) \\
 -M_b &= -R'x/3 = -w_0 x^3/(6L)
 \end{aligned}
 \tag{d}$$

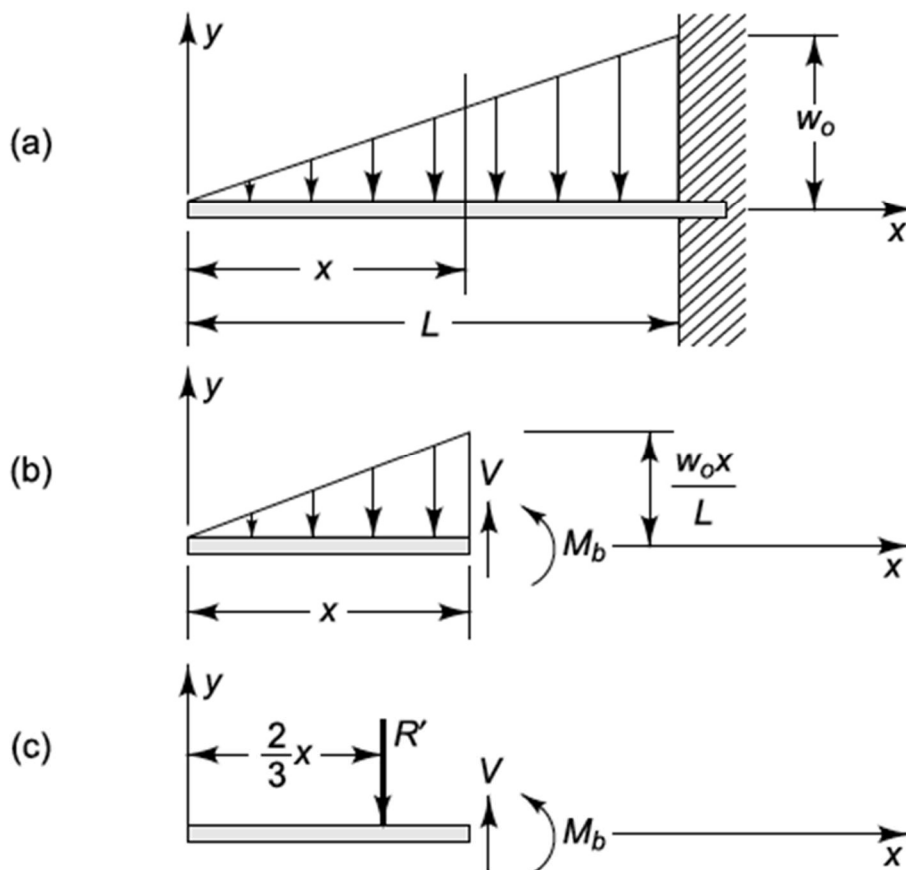

Fig. 3.13 Example 3.4. Distributed loading on a segment of a beam is replaced by its resultant