

CH. 4

STRESS AND STRAIN

4.1 Introduction

→ In this chapter, to derive the overall behavior of a body from the properties of differentially small elements within the body still requires the use of the three fundamental principles of equilibrium, geometric compatibility, and the relations between force and deformation.

▶ CH. 4: The equilibrium and geometry of deformation at a point are considered. → Stress and Strain

CH. 5: The force, deformation, and their relation at a point are observed for structures under various (mechanical and thermal) loading conditions. → Stress-Strain-Temperature Relations

4.2 Stress

▶ Four major characteristics of stress

- i) The physical dimensions of stress are force per unit area.
- ii) Stress is defined at a point upon an imaginary plane or boundary dividing the material into two parts.
- iii) Stress is a vector equivalent to the action of one part of the material upon another.
- iv) The direction of the stress vector is not restricted.

▶ Stress Vector [$\mathbf{T}^{(n)}$]

▷ Definition

$$\mathbf{T}^{(n)} = \lim_{\Delta A \rightarrow 0} \frac{\Delta \mathbf{F}}{\Delta A} \quad (4.1)$$

The stress vector $\mathbf{T}^{(n)}$ is force intensity or stress acting at the point O on a plane whose normal is \mathbf{n} passing through O .

cf. $\mathbf{T}^{(n)}$ does not act in general in the direction of \mathbf{n} .

cf. $\Delta A \rightarrow 0$ means $\Delta A \rightarrow \epsilon^2$, and ϵ^2 is the minimum area for continuous $\Delta \mathbf{F}$.

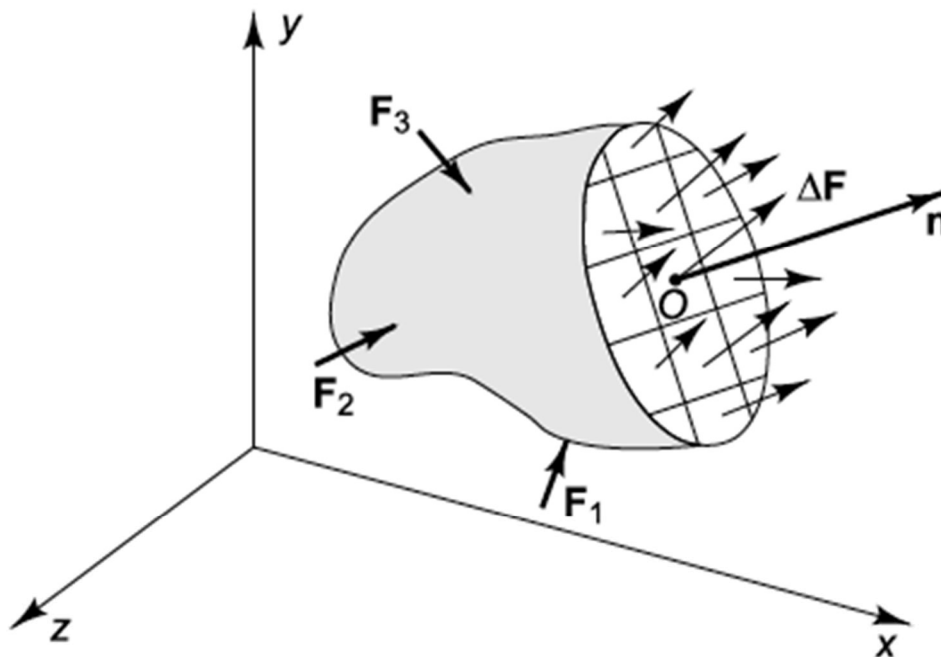

Fig. 4.2

Internal forces acting on a plane whose normal is \mathbf{n}

▷ The components in the Cartesian coordinate system

$$\mathbf{T}^{(n)} = T_x^{(n)} \mathbf{i} + T_y^{(n)} \mathbf{j} + T_z^{(n)} \mathbf{k} \quad (4.2)$$

▷ The stress components on the x face at point O (see Fig. 4.4, 4.5)

$$\sigma_x = \lim_{\Delta A_x \rightarrow 0} \frac{\Delta F_x}{\Delta A_x}$$

$$\tau_{xy} = \lim_{\Delta A_x \rightarrow 0} \frac{\Delta F_y}{\Delta A_x}$$

$$\tau_{xz} = \lim_{\Delta A_x \rightarrow 0} \frac{\Delta F_z}{\Delta A_x} \tag{4.3}$$

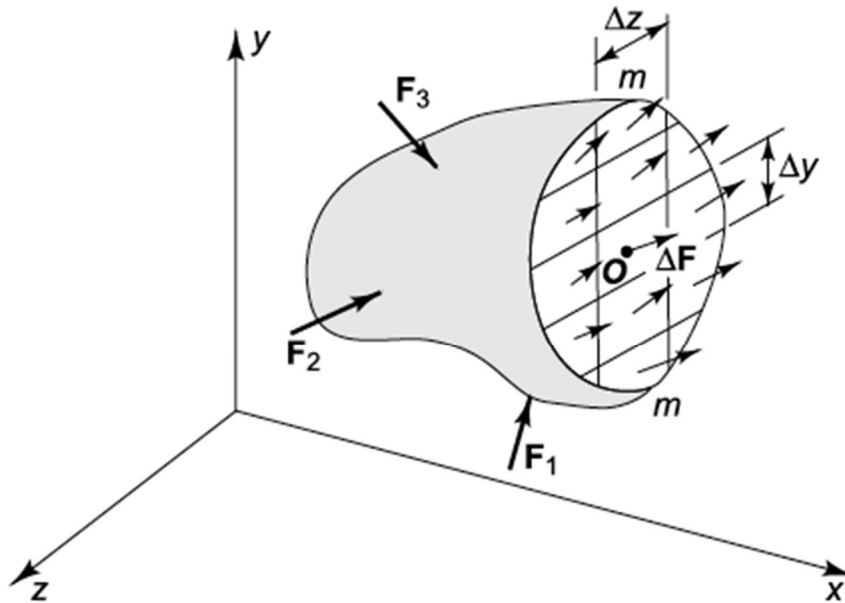

Fig. 4.4 Internal forces acting on plane mm

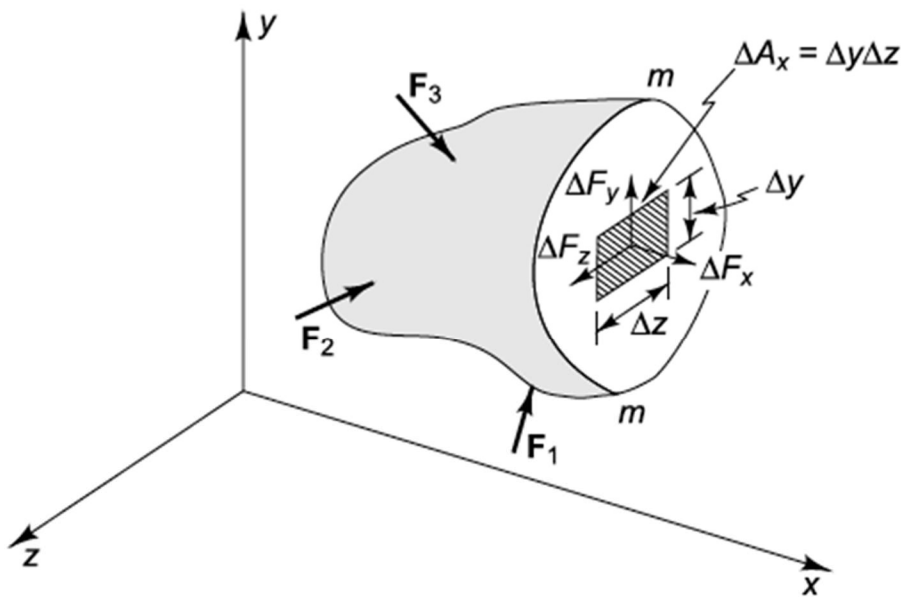

Fig. 4.5 Rectangular components of the force vector ΔF acting on the small area centered on point O

▷ Sign convention

- i) When a positively directed force component acts on positive face
→ (+)

- ii) When a negatively directed force component acts on negative face
 $\rightarrow (+)$

► Stress component

$$\begin{bmatrix} \sigma_x & \tau_{xy} & \tau_{xz} \\ \tau_{yx} & \sigma_y & \tau_{yz} \\ \tau_{zx} & \tau_{zy} & \sigma_z \end{bmatrix} \quad (4.4)$$

- i) The primes are used to indicate that the stress components on opposite face.
- ii) The stress components in Fig. 4.8 should be thought of as average values over the respective faces of the parallelepiped.

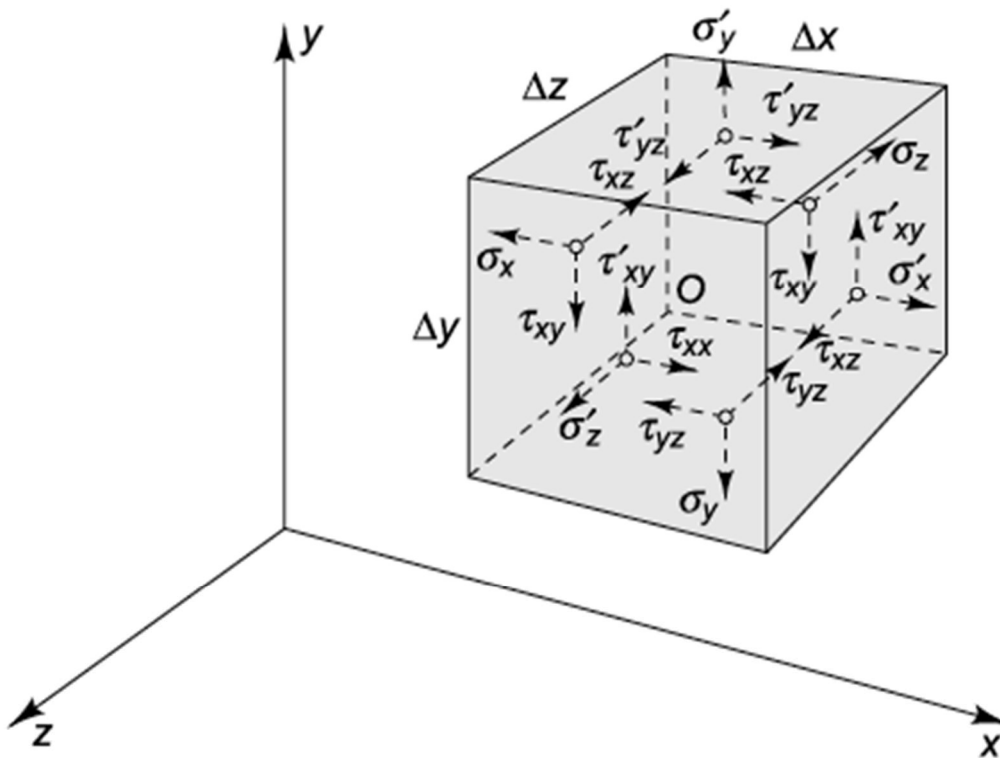

Fig. 4.8

Stress components acting on the six sides of a parallelepiped

► Index or Indicial notation

\rightarrow Indicial notation for stress is often more convenient for general discussions in elasticity.

→ In indicial notation the coordinate axes x , y , and z are replaced by numbered axes, x_1 , x_2 , and x_3 , respectively.

$$\sigma_x ; \sigma_{11} = \lim_{\Delta A_1 \rightarrow 0} \frac{\Delta F_1}{\Delta A_1}$$

$$\tau_{xy} ; \sigma_{12} = \lim_{\Delta A_1 \rightarrow 0} \frac{\Delta F_2}{\Delta A_1}$$

$$\tau_{xz} ; \sigma_{13} = \lim_{\Delta A_1 \rightarrow 0} \frac{\Delta F_3}{\Delta A_1}$$

$$\sigma_{ij} = \lim_{\Delta A_i \rightarrow 0} \frac{\Delta F_j}{\Delta A_i} \quad (4.5)$$

4.3 Plane Stress

→ A thin sheet is being pulled by forces in the plane of the sheet. If we take the xy plane to be the plane of the sheet, then σ_x , σ'_x , σ_y , σ'_y , τ_{xy} , τ'_{xy} , τ_{yx} , τ'_{yx} will be the only stress components acting on the parallelepiped. Therefore, the state of stress at a given point will only depend upon the four stress components.

$$\begin{bmatrix} \sigma_x & \tau_{xy} \\ \tau_{yx} & \sigma_y \end{bmatrix} \quad (4.6)$$

→ This combination of stress components is called plane stress in the xy plane.

Ex) Slender members under axial loading, Axis under torsion, Stress in the beam, etc.

4.4 Equilibrium of a Differential Element in Plane Stress

→ Using the concept of the partial derivative, we can approximate the amount of a stress component changes between two points separated by a small distance as the product of the partial derivative in the direction connecting the two points.

→ If a continuous body is in equilibrium, then any isolated part of the body must be acted upon by an equilibrium set of forces.

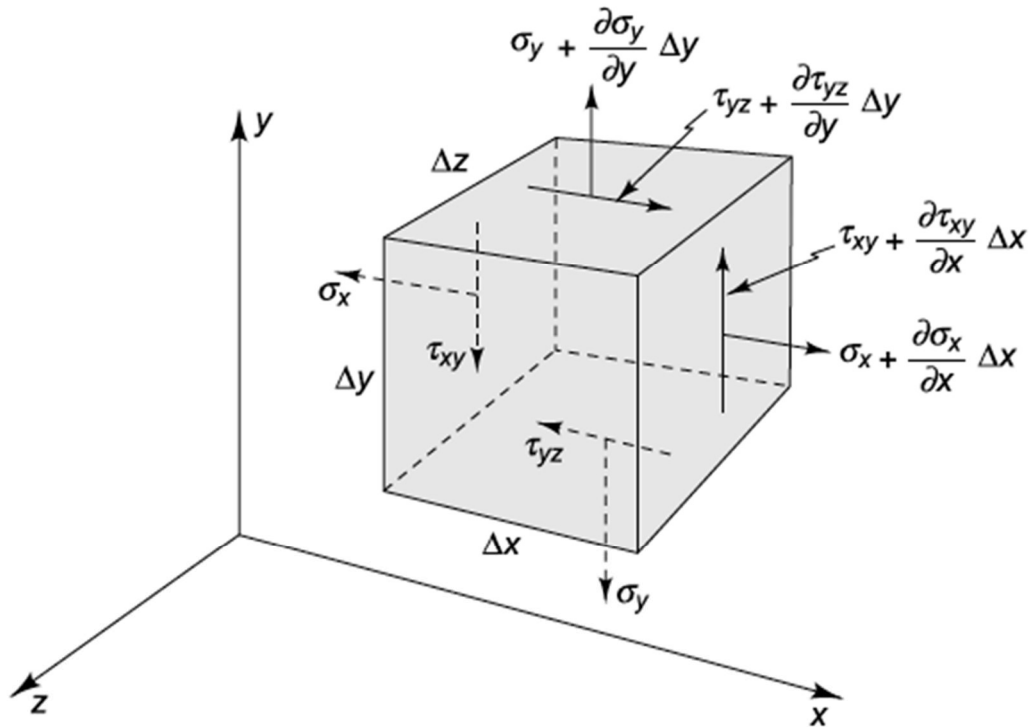

Fig. 4.10 Stress components in plane stress expressed in terms of partial derivatives

→ If all systems are in equilibrium, the element shown in Fig. 4.10 must satisfy the equilibrium conditions $\sum \mathbf{M} = 0$ and $\sum \mathbf{F} = 0$.

► Proof of $\tau_{yx} = \tau_{xy}$ (Eq. 4.12)

From Fig. 4.10,

$$\sum \mathbf{M} = \left\{ (\tau_{xy} \Delta y \Delta z) \frac{\Delta x}{2} + \left[\left(\tau_{xy} + \frac{\partial \tau_{xy}}{\partial x} \Delta x \right) \Delta y \Delta z \right] \frac{\Delta x}{2} - (\tau_{yx} \Delta x \Delta z) \frac{\Delta y}{2} - \left[\left(\tau_{yx} + \frac{\partial \tau_{yx}}{\partial y} \Delta y \right) \Delta x \Delta z \right] \frac{\Delta y}{2} \right\} \mathbf{k} = 0 \tag{4.8}$$

$$\therefore \tau_{xy} + \frac{\partial \tau_{xy}}{\partial x} \frac{\Delta x}{2} - \tau_{yx} - \frac{\partial \tau_{yx}}{\partial y} \frac{\Delta y}{2} = 0 \tag{4.11}$$

For the limits $\Delta x \rightarrow 0, \Delta y \rightarrow 0$

$$\tau_{yx} = \tau_{xy} \tag{4.12}$$

In the limit as Δx and Δy go to zero,

cf. In general, $\tau_{xy} = \tau_{yx}$, $\tau_{xz} = \tau_{zx}$, $\tau_{yz} = \tau_{zy}$.

► Proof of $\frac{\partial \sigma_x}{\partial x} + \frac{\partial \tau_{xy}}{\partial y} = 0$, $\frac{\partial \tau_{xy}}{\partial x} + \frac{\partial \sigma_y}{\partial y} = 0$ (Eq. 4.13)

From Fig. 4.10,

$$\begin{aligned} \sum F_x &= \left(\sigma_x + \frac{\partial \sigma_x}{\partial x} \Delta x \right) \Delta y \Delta z + \left(\tau_{yx} + \frac{\partial \tau_{yx}}{\partial y} \Delta y \right) \Delta x \Delta z \\ &- \sigma_x \Delta y \Delta z - \tau_{yx} \Delta x \Delta z = 0 \end{aligned} \quad (4.9)$$

$$\begin{aligned} \sum F_y &= \left(\sigma_y + \frac{\partial \sigma_y}{\partial y} \Delta y \right) \Delta x \Delta z + \left(\tau_{xy} + \frac{\partial \tau_{xy}}{\partial x} \Delta x \right) \Delta y \Delta z \\ &- \sigma_y \Delta x \Delta z - \tau_{xy} \Delta y \Delta z = 0 \end{aligned} \quad (4.10)$$

If we now return to Eqs (4.9) and (4.10), we find, using (4.12), that the requirements of $\sum \mathbf{F} = 0$ at a point lead to the differential equations.

$$\begin{aligned} \frac{\partial \sigma_x}{\partial x} + \frac{\partial \tau_{xy}}{\partial y} &= 0 \\ \frac{\partial \tau_{xy}}{\partial x} + \frac{\partial \sigma_y}{\partial y} &= 0 \end{aligned} \quad (4.13)$$

cf. We have found the requirements (4.12) and (4.13) which equilibrium imposes upon the stress components acting on perpendicular faces.

► The three dimensional equations corresponding to Eq. (4.13)

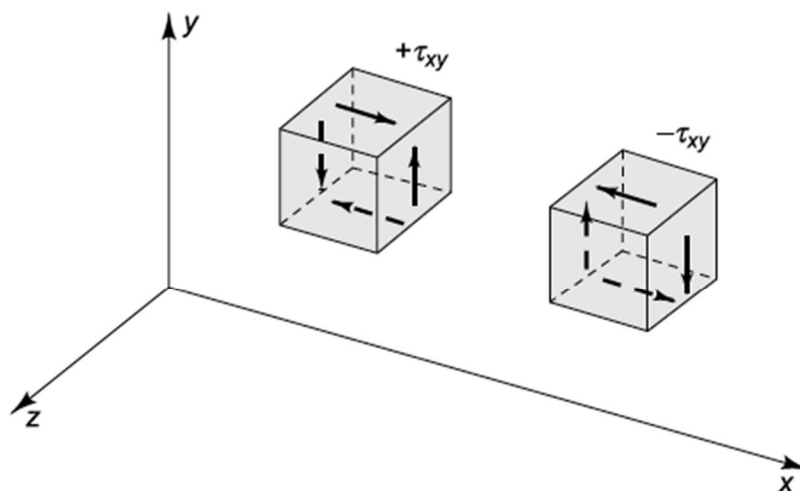

Fig. 4.11 Definition of positive and negative τ_{xy}

$$\frac{\partial \sigma_{11}}{\partial x_1} + \frac{\partial \sigma_{21}}{\partial x_2} + \frac{\partial \sigma_{31}}{\partial x_3} = 0$$

$$\frac{\partial \sigma_{12}}{\partial x_1} + \frac{\partial \sigma_{22}}{\partial x_2} + \frac{\partial \sigma_{32}}{\partial x_3} = 0 \quad (4.14)$$

$$\frac{\partial \sigma_{13}}{\partial x_1} + \frac{\partial \sigma_{23}}{\partial x_2} + \frac{\partial \sigma_{33}}{\partial x_3} = 0$$

$$\rightarrow \sum_{i=1}^3 \frac{\partial \sigma_{ij}}{\partial x_i} = 0 \quad (j = 1,2,3)$$

$$\rightarrow \frac{\partial \sigma_{ij}}{\partial x_i} = 0 \quad (4.15)$$

cf. Moment equilibrium has the result (4.12) that the original four stress components are reduced to three independent components in a two dimensional case, and for a three dimensional case of stress, moment equilibrium will reduce the original nine components of stress to six independent ones.

4.5 Stress Components Associated with Arbitrarily Oriented Faces in Plane Stress

- ▶ We examine further the problem of equilibrium of stress at a point and determine relationships which must exist between the stress components associated with faces which are not perpendicular to each other.
- ▶ Let us assume that we know the values of the stress components at some point in a body subjected to plane stress.

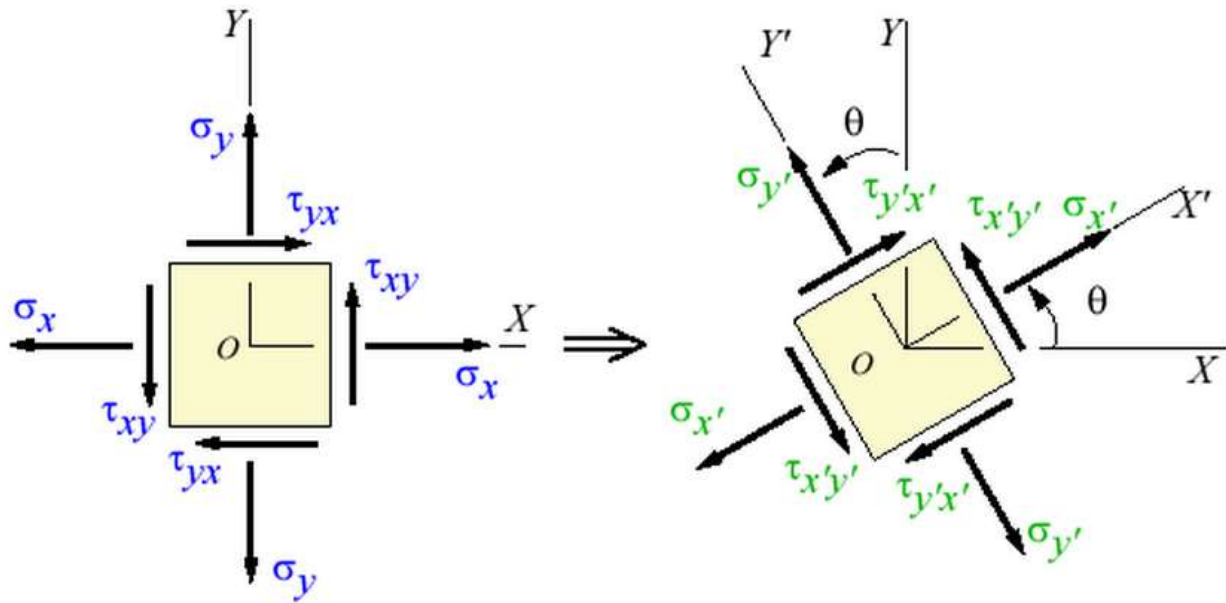

- ▶ To determine the stress components $\sigma_{x'}$ and $\tau_{x'y'}$ in terms of $\sigma_x, \sigma_y, \tau_{xy}$, and θ , consider the equilibrium of a small wedge centered on point O as shown in Fig. 4.15.

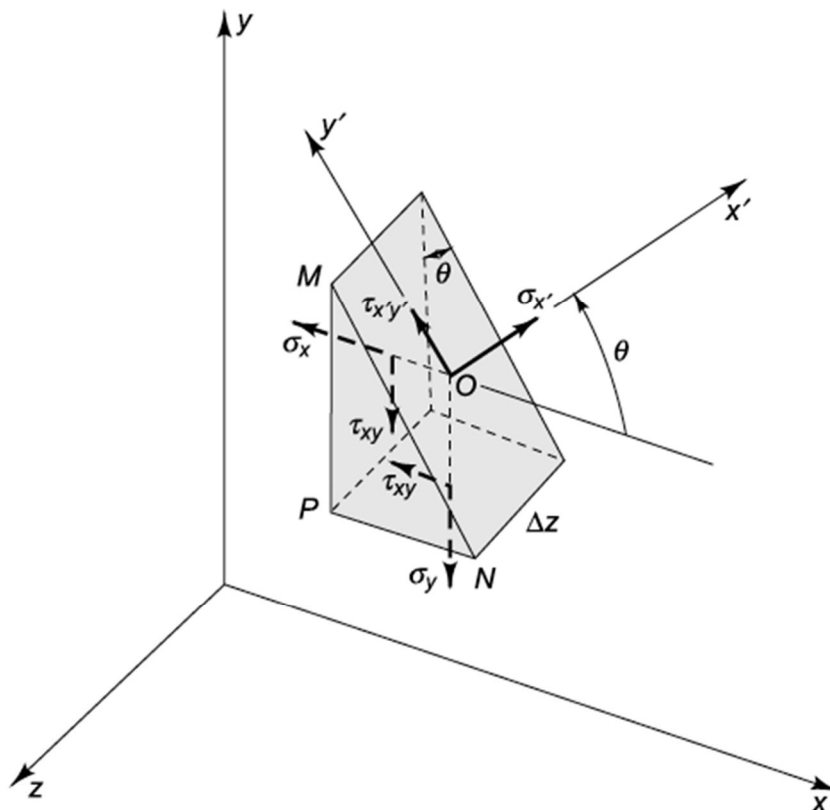

Fig. 4.15 Stress components acting on faces of a small wedge, cut from body of Fig. 4.14, which is in a state of plane stress in the xy plane

$$\begin{aligned} \sum F_{x'} &= \sigma_{x'}(A_0 \sec \theta) - \sigma_x A_0 \cos \theta - \tau_{xy} A_0 \sin \theta - \\ &\sigma_y (A_0 \tan \theta) \sin \theta - \tau_{yx} (A_0 \tan \theta) \cos \theta = 0 \end{aligned} \quad (4.21)$$

$$\begin{aligned} \sum F_{y'} &= \tau_{x'y'} A_0 \sec \theta + \sigma_x A_0 \sin \theta - \tau_{xy} A_0 \cos \theta - \\ &\sigma_y (A_0 \tan \theta) \cos \theta + \tau_{yx} (A_0 \tan \theta) \sin \theta = 0 \end{aligned} \quad (4.22)$$

$$\therefore \begin{cases} \sigma_{x'} = \sigma_x \cos^2 \theta + \sigma_y \sin^2 \theta + 2\tau_{xy} \sin \theta \cos \theta \\ \tau_{x'y'} = (\sigma_y - \sigma_x) \sin \theta \cos \theta + \tau_{xy} (\cos^2 \theta - \sin^2 \theta) \end{cases} \quad (4.23)$$

where $A_0 = \overline{MP} \times \Delta z$

→ From (4.23) it is evident that in plane stress if we know the stress components on any two perpendicular faces, we know the stress components on all faces whose normals lie in the plane.

▷ In particular, acting on a face perpendicular to the y' axis.

→ If we substitute $\theta + 90^\circ$ for θ ,

$$\sigma_{y'} = \sigma_x \sin^2 \theta + \sigma_y \cos^2 \theta - 2\tau_{xy} \sin \theta \cos \theta \quad (4.24)$$

$$-\tau_{y'x'} = \tau_{x'y'}$$

$$= (\sigma_y - \sigma_x) \sin \theta \cos \theta + \tau_{xy} (\cos^2 \theta - \sin^2 \theta)$$

→ Specification of a state of stress in plane stress involves knowledge of three stress components, most conveniently taken as the normal and shear components on two perpendicular faces.

4.6 Mohr's Circle Representation of Plane Stress

$$\cos^2 \theta = \frac{1 + \cos 2\theta}{2}, \quad \sin^2 \theta = \frac{1 - \cos 2\theta}{2}, \quad \sin \theta \cos \theta = \frac{1}{2} \sin 2\theta$$

→ In order to facilitate application of (4.23) and (4.24), we shall make use of a simple graphical representation.

$$\begin{aligned}
 \sigma_{x'} &= \frac{\sigma_x + \sigma_y}{2} + \frac{\sigma_x - \sigma_y}{2} \cos 2\theta + \tau_{xy} \sin 2\theta \\
 \sigma_{y'} &= \frac{\sigma_x + \sigma_y}{2} - \frac{\sigma_x - \sigma_y}{2} \cos 2\theta - \tau_{xy} \sin 2\theta \\
 \tau_{x'y'} &= -\frac{\sigma_x - \sigma_y}{2} \sin 2\theta + \tau_{xy} \cos 2\theta \\
 \sigma_{x'} + \sigma_{y'} &= \sigma_x + \sigma_y = \text{const}
 \end{aligned}
 \tag{4.25}$$

cf. Sign convention of shear stress

→ Positive shear stress τ_{xy} (see Fig. 4.11) is plotted downward at x and upward at y . Negative shear stress is plotted upward at x and downward at y .

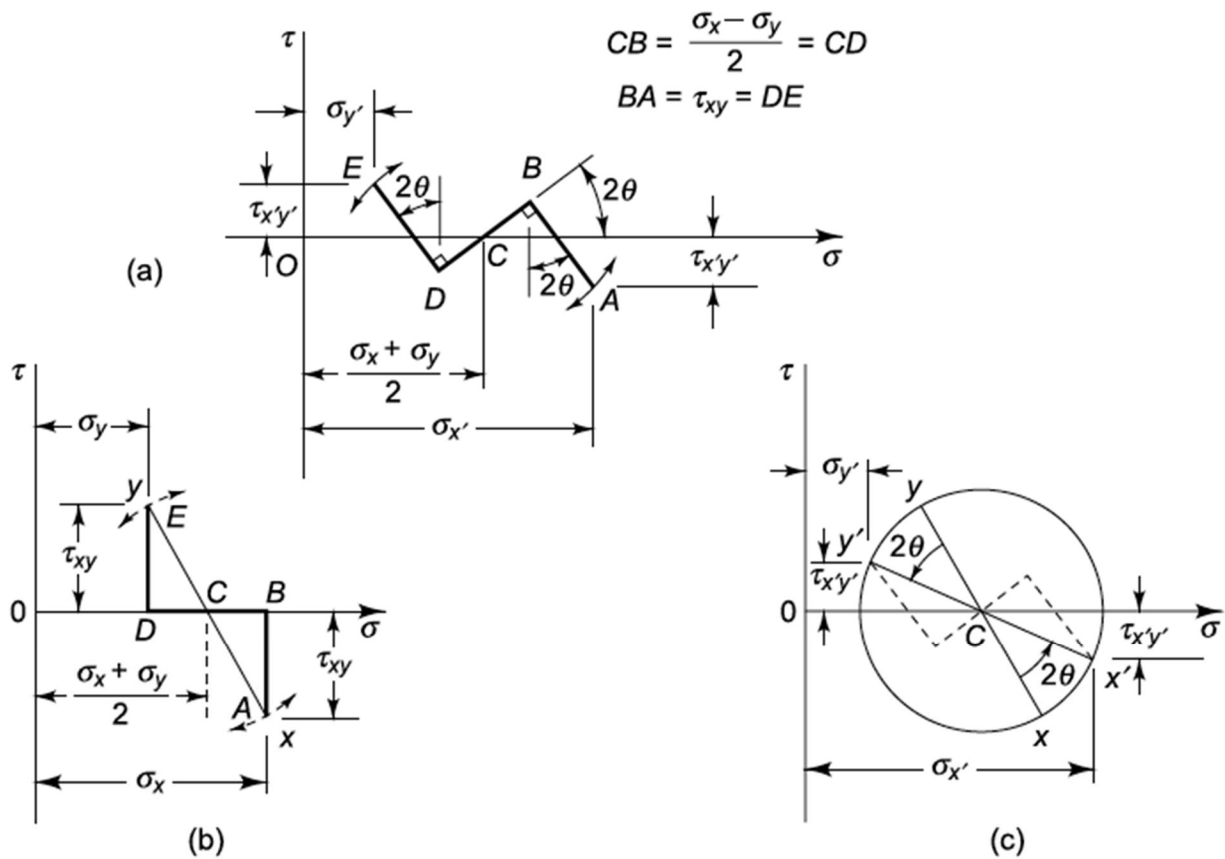

Fig. 4.16 Development of Mohr's circle for stress

► To construct Mohr's circle (see Fig. 4.17)

- i) Using the sign convention for stress components just given, we locate the point x with coordinates σ_x , and τ_{xy} , and the point

y with coordinates σ_y , and τ_{xy} .

- ii) We join points x and y with a straight line intersecting the σ axis at point C , which is to be the center of Mohr's circle. The abscissa of C is

$$c = (\sigma_x + \sigma_y)/2 \quad (4.26)$$

- iii) With C as center and xy as diameter we draw the circle. The radius of the circle is

$$r = \left[\left(\frac{\sigma_x - \sigma_y}{2} \right)^2 + \tau_{xy}^2 \right]^{1/2} \quad (4.27)$$

Once the circle has been constructed, it may be used to determine the stress components $\sigma_{x'}$, $\sigma_{y'}$, and $\tau_{x'y'}$ shown in Fig. 4.17 (d). These stress components apply to the same physical point O in the body but are in respect to the axes $x'y'$ which make an angle θ with the original xy axes.

- iv) We locate the $x'y'$ diameter with respect to the xy diameter in Mohr's circle by laying off the *double angle* 2θ in Fig. 4.17 (c) in the same sense as the rotation θ which carries the xy axes into the $x'y'$ axes in Fig. 4.17 (d).
- v) Using the sign convention for stress components in Mohr's circle, we read off the values of $\sigma_{x'}$ and $\tau_{x'y'}$ as the coordinates of point x' and the values of $\sigma_{y'}$ and $\tau_{x'y'}$ as the coordinates of point y'

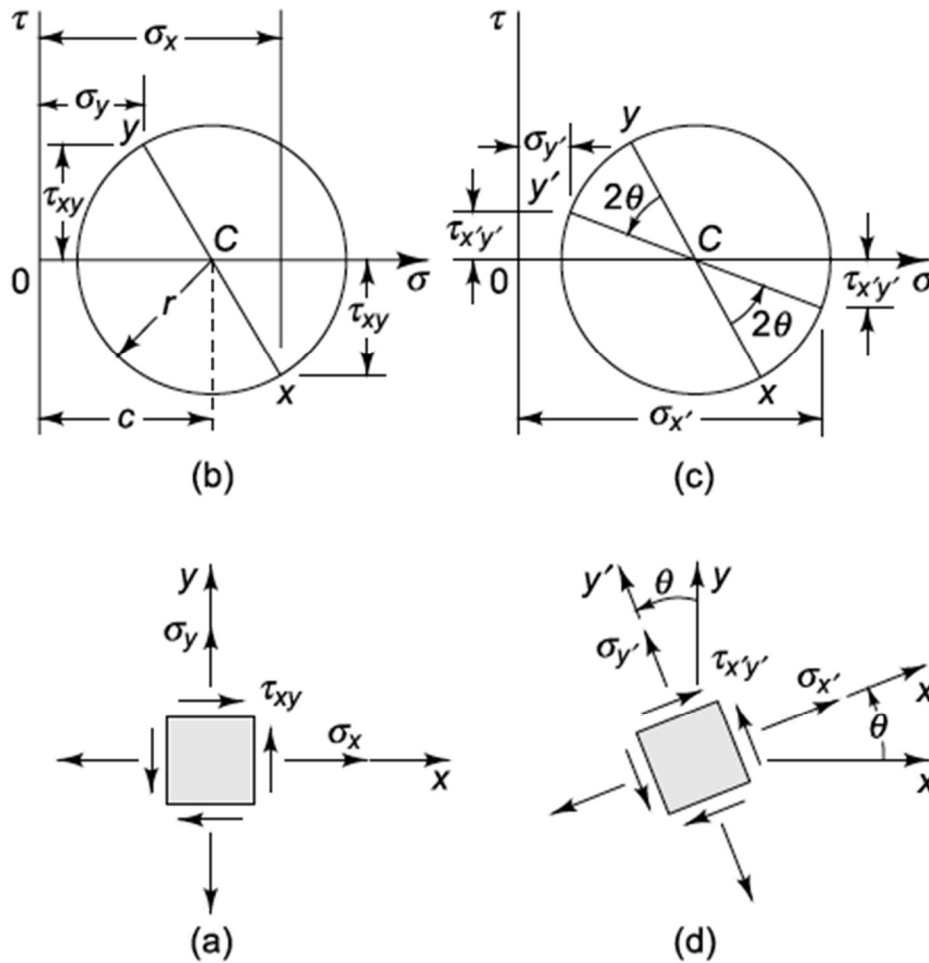

Fig. 4.17 Stress components (a) are used to construct Mohr's circle (b). Rotation of diameter through double angle in (c) provides stress components for inclined element (d)

► Example 4.1 We consider a thin sheet pulled in its own plane so that the stress components with respect to the xy axes are as given in Fig. 4.18 (a). We wish to find the stress components with respect to the ab axes which are inclined at 45° to the xy axes.

cf. Though we set the coordinate axis a like the left figure, the Mohr's circle is same with Fig. 4.18 (a).

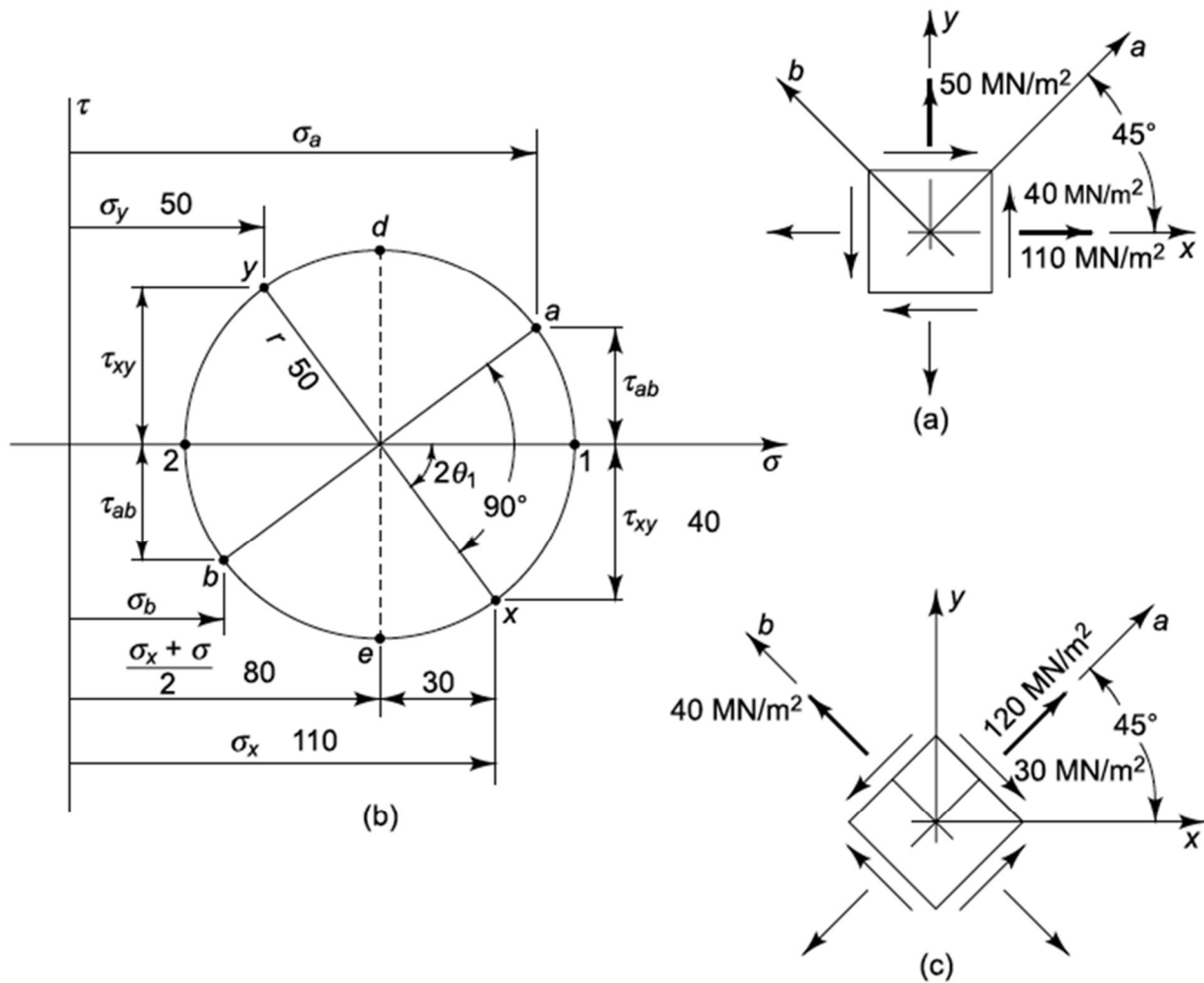

Fig. 4.18 Example 4.1

$$2\theta_1 = \tan^{-1}(40/30) = 53.2^\circ$$

$$r = \sqrt{(30)^2 + (40)^2} = 50 \text{ MN/m}^2$$

$$\sigma_a = 80 + 50 \cos(90^\circ - 53.2^\circ) = 120 \text{ MN/m}^2$$

$$\sigma_b = 80 - 50 \cos(90^\circ - 53.2^\circ) = 40 \text{ MN/m}^2$$

$$\tau_{ab} = -50 \sin(90^\circ - 53.2^\circ) = -30 \text{ MN/m}^2$$

► Principle Axes & Principle Stress

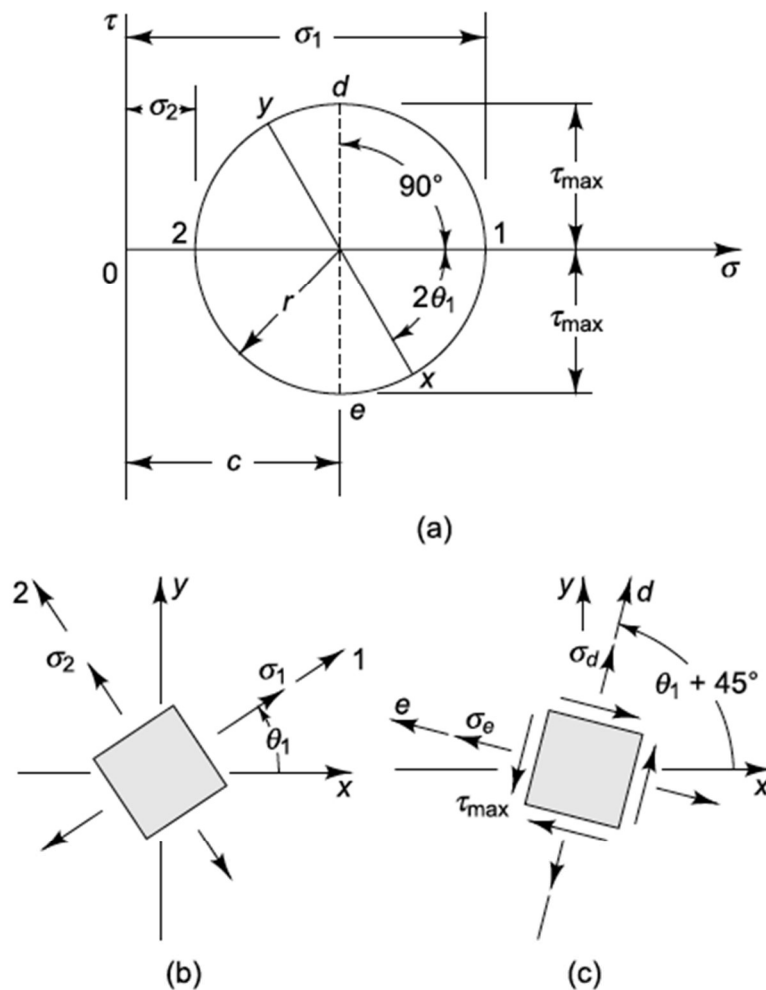

Fig. 4.19

(a) Principal stresses σ_1 and σ_2 and maximum shear stress τ_{\max} indicated on Mohr's circle. (b) Element oriented along principal axes. (c) Element oriented along axes of maximum shear

▷ Principle stress

→ σ_1 is the maximum possible normal stress component, and σ_2 is the minimum possible normal stress component at certain location in the body.

▷ Principle axes

→ The axes which is applied by only normal stress.

▷ Maximum Shear Stress

→ The difference between the maximum and minimum of $\tau_{x'y'}$ occur at perpendicular faces. At this location, the magnitude of the shear stresses is same but the sign of them is different.

cf. The axes of maximum shear are inclined at 45° with respect to the principal axes.

▷ The calculation of the principal axes

$$\frac{d\sigma_{x'}}{d\theta} = -(\sigma_x - \sigma_y)\sin 2\theta + \tau_{xy}\cos 2\theta = 0$$

$$\tan 2\theta_p = \frac{2\tau_{xy}}{\sigma_x - \sigma_y}$$

▷ The calculation of the principal stress

$$\sigma_{1,2} = \frac{\sigma_x + \sigma_y}{2} \pm \sqrt{\left(\frac{\sigma_x - \sigma_y}{2}\right)^2 + \tau_{xy}^2}$$

▷ The calculation of the axes of maximum shear stress

$$\frac{d\tau_{x'y'}}{d\theta} = -(\sigma_x - \sigma_y)\cos 2\theta - 2\tau_{xy}\sin 2\theta = 0$$

$$\tan 2\theta_s = -\frac{\sigma_x - \sigma_y}{2\tau_{xy}}$$

▷ The calculation of the maximum shear stress

$$\begin{aligned}\tau_{max} &= \sqrt{\left(\frac{\sigma_x - \sigma_y}{2}\right)^2 + \tau_{xy}^2} \\ &= \frac{\sigma_1 - \sigma_2}{2}\end{aligned}$$

► Synopsis

$$\sigma_{1,2} = \frac{\sigma_x + \sigma_y}{2} \pm \sqrt{\left(\frac{\sigma_x - \sigma_y}{2}\right)^2 + \tau_{xy}^2}$$

$$\tau_{max} = \sqrt{\left(\frac{\sigma_x - \sigma_y}{2}\right)^2 + \tau_{xy}^2} = \frac{\sigma_1 - \sigma_2}{2}$$

$$\tan 2\theta_p = \frac{2\tau_{xy}}{\sigma_x - \sigma_y}$$

$$\sigma_{x'} = \frac{\sigma_x + \sigma_y}{2} + \frac{\sigma_x - \sigma_y}{2} \cos 2\theta + \tau_{xy} \sin 2\theta$$

$$\sigma_{y'} = \frac{\sigma_x + \sigma_y}{2} - \frac{\sigma_x - \sigma_y}{2} \cos 2\theta - \tau_{xy} \sin 2\theta$$

$$\tau_{x'y'} = -\frac{\sigma_x - \sigma_y}{2} \sin 2\theta + \tau_{xy} \cos 2\theta$$

$$\sigma_{x'} + \sigma_{y'} = \sigma_x + \sigma_y$$

4.7 Mohr's Circle Representation of a General State of Stress (Stress Analysis in three dimension)

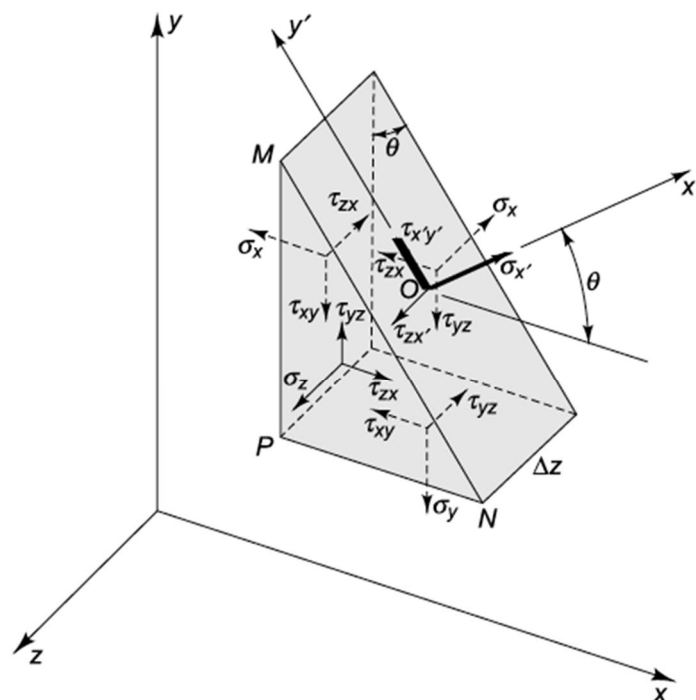

Fig. 4.21 Stress components acting on faces of a small wedge cut from a body in general state of stress

- The stress components $\sigma_{x'}$ and $\tau_{x'y'}$ are unaffected by the stress components associated with the z axis. This results from the fact that for force equilibrium in the x' and y' directions the contributions of the components τ_{zx} and τ_{yz} acting on the $+z$ face of the wedge are

exactly balanced by those of the components τ_{zx} and τ_{yz} acting on the $-z$ face.

- If we resolve the stress components τ_{zx} and τ_{yz} on the $+z$ face into components perpendicular and parallel to \overline{MN} , we find that the right-hand side of (4.30) is the sum of the components perpendicular to \overline{MN} .

$$\tau_{zx'} \Delta Z \overline{MN} + \sigma_z \frac{\overline{NPM\overline{P}}}{2} - \tau_{zx} \Delta Z \overline{MP} - \tau_{yz} \Delta Z \overline{NP} - \sigma_z \frac{\overline{NPM\overline{P}}}{2} = 0$$

$$\tau_{zx'} = \tau_{zx} \cos\theta + \tau_{yz} \sin\theta \quad (4.30)$$

► Conclusion of the three-dimensional stress

- i) The results given by (4.25) and the Mohr's circle representation of these are correct whether or not the stress components σ_z , τ_{yz} , and τ_{zx} are zero.
- ii) If either τ_{yz} or τ_{zx} is nonzero, then in general there will exist a shear-stress component $\tau_{zx'}$ on the x' face in addition to $\tau_{x'y'}$. In such a case the 1 and 2 axes of Fig. 4.19 should not be called principal axes since we wish to retain the designation *principal axis of stress* for the normal to a face on which *no* shear-stress component acts.

► Mohr's circle of three-dimensional infinitesimal volume (for $\sigma_3 = 0$)

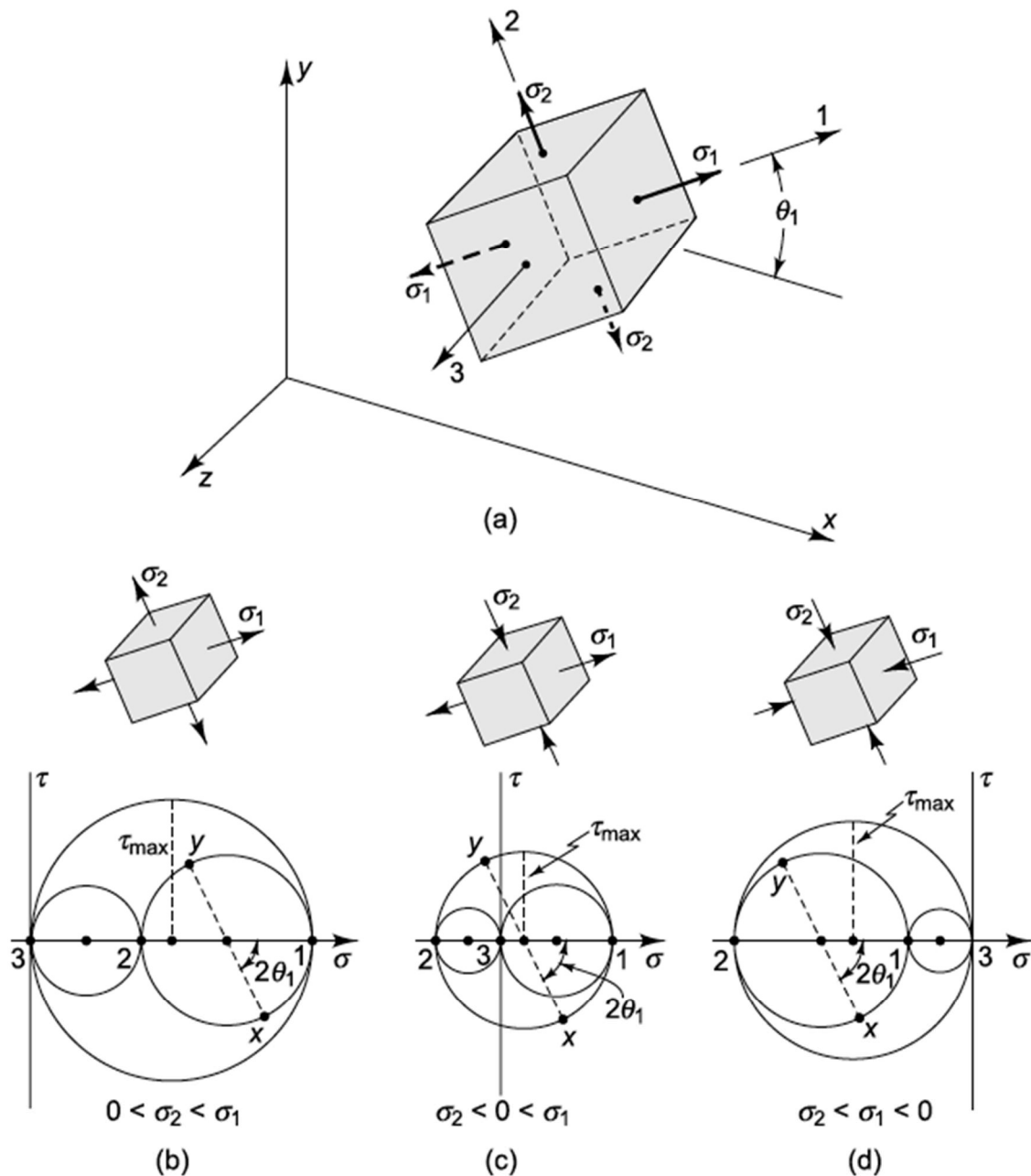

Fig. 4.22 Plane stress in xy plane

→ According to the independence of the stress components, we can obtain three Mohr's circles as shown in Fig. 4.22.

► General state of stress (for $\sigma_3 \neq 0$)

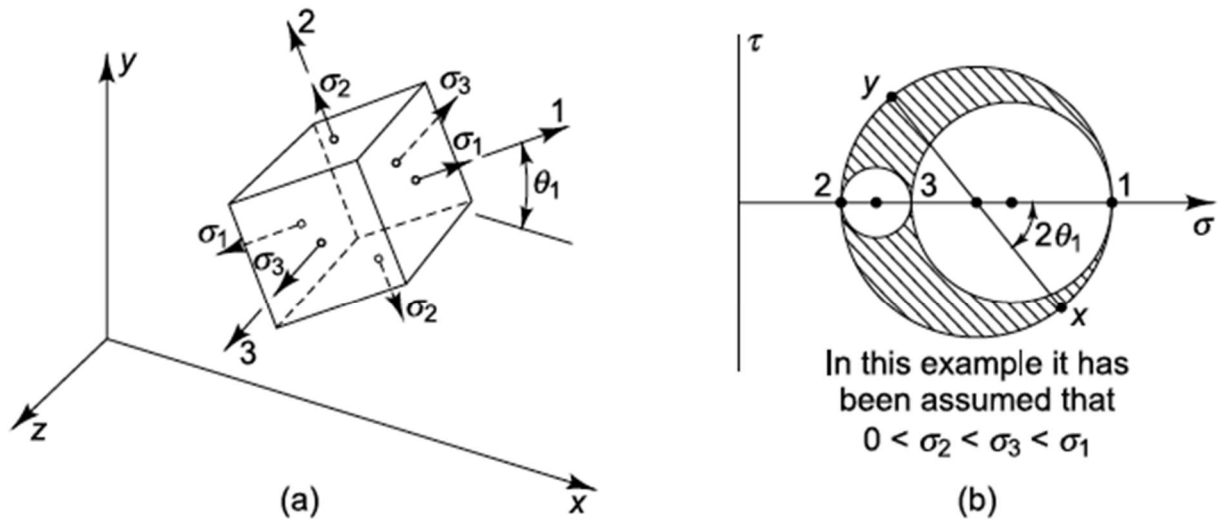

Fig. 4.23 Three-dimensional state of stress

→ The stress components for all possible planes are contained in the shaded area in Fig. 4. 23 (b) (where we have assumed a case in which $0 < \sigma_2 < \sigma_3 < \sigma_1$).

cf. In Fig 4.23 (b) the shear stress τ is the resultant shear-stress component acting on the plane (for example, $\sqrt{(\tau_{x'y'})^2 + (\tau_{zx'})^2}$ in Fig. 4.21).

If the six stress components associated with any three mutually perpendicular faces are specified, it is possible to develop equations similar to (4.23) for the normal and resultant shear-stress components on any arbitrary plane passed through the point.