

## 11. Electroactive layers and modified electrodes (Ch. 14)

Types, preparation, & properties of films & modified electrodes

Substrates

Monolayers

Polymers

Inorganic films

Biological related materials

Composite & multilayer assemblies

Electrochemical responses of adsorbed monolayers

Overview of processes at modified electrodes

Blocking layers

Other methods of characterization

## **Introduction**

*Chemically modified electrodes*: electroactive monolayers & thicker films on conductive substrates

→ fuel cells, batteries, electrochromic devices, active displays, corrosion protection, molecular electronic devices, sensors and so on

## **Types, preparation, & properties of films & modified electrodes**

### **Substrate**

Metal (Pt, Au), carbon, semiconductor ( $\text{SnO}_2$  etc),

→ single crystals, films, high surface area small particles

### **Monolayers**

#### **(a) Irreversible adsorption**

Substrate environment is energetically more favorable than that in solution

S-containing compds on Hg, Au, other metal surfaces because metal-S interactions

Halides,  $\text{SCN}^-$ ,  $\text{CN}^-$  & organic compds on metal & carbon surfaces

Functional groups on metal or carbon via oxidation

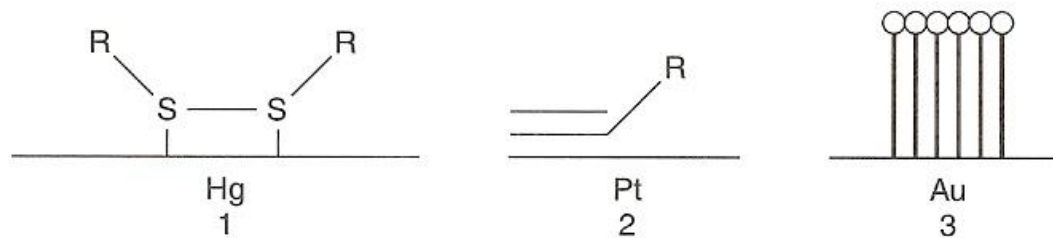

(a)

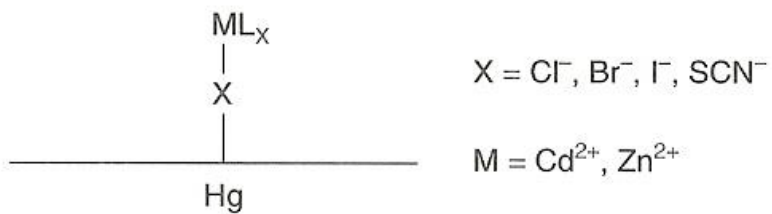

(b)

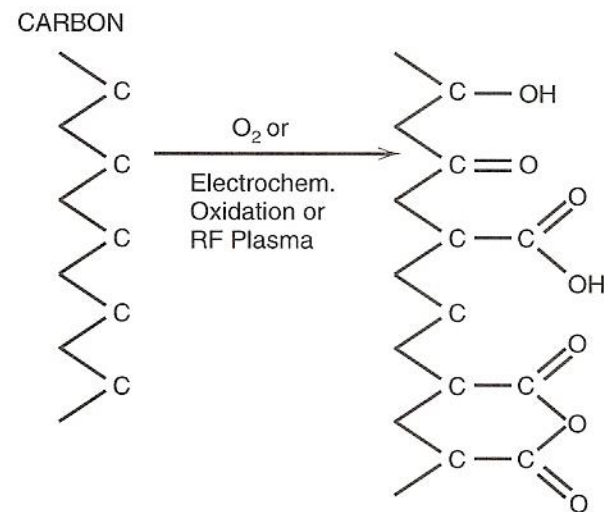
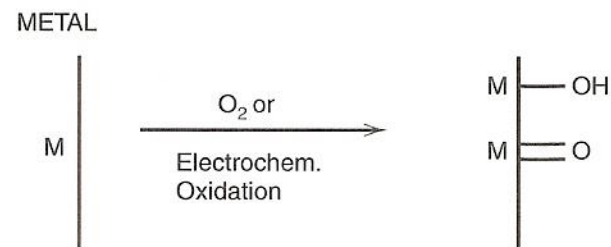

## (b) Covalent attachment

Strong attachment to the substrate by covalent linking of the desired component to surface groups

→ covalent linking procedures employ organosilanes & other linking agents

Ferrocenes, viologens,  $M(\text{bpy})_x^{n+}$  ( $M = \text{Ru}, \text{Os}, \text{Fe}$ )

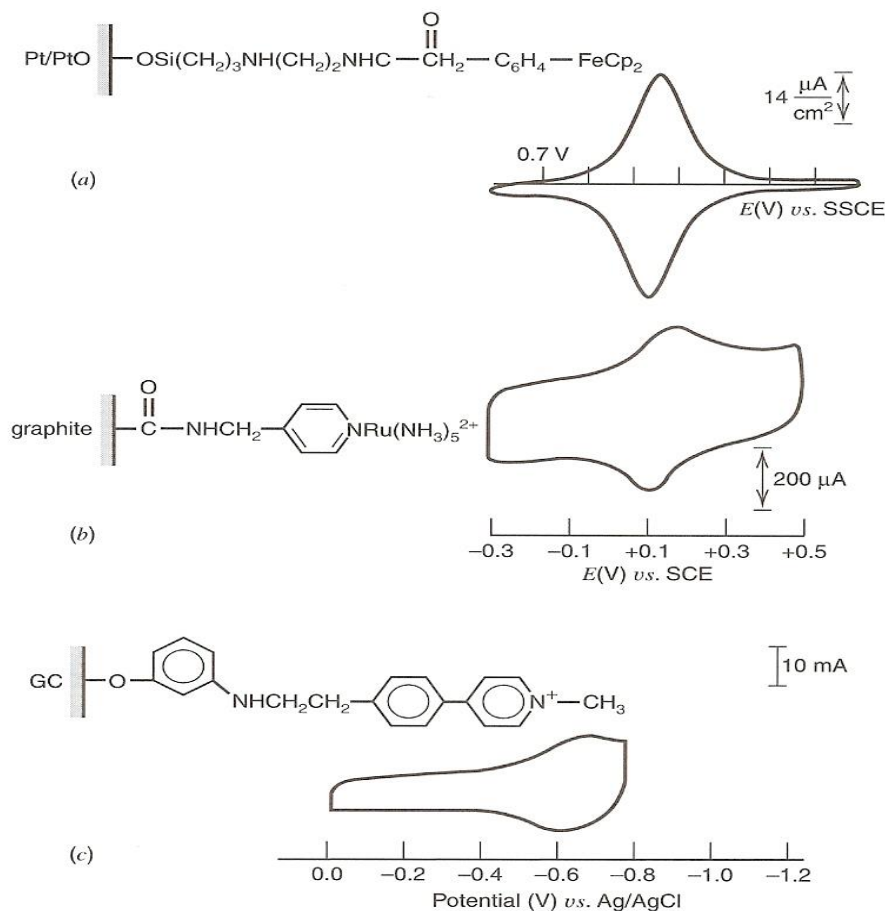

### (c) Organized assemblies

Monolayers of surface-active compds (*langmuir-Blodgett (LB) films*) can be transferred from liquid/air interface to a substrate surface

*Self-assembly* as a spontaneous process

e.g., organosulfur (e.g., thiol) compds with long chain alkyl groups on Au

## **Polymers**

### (a) Types

*Electroactive polymers*: oxidizable or reducible groups covalently linked to the polymer backbone. e.g., poly(vinylferrocene), polymerized  $\text{Ru}(\text{vbpy})_3^{2+}$

*Coordinating (ligand-bearing) polymers*: contain groups that can coordinate to species like metal ions. e.g., poly(4-vinylpyridine)

*Ion-exchange polymers (polyelectrolytes)*: contain charged sites that can bind ions from solution via an ion-exchange process. e.g., Nafion, polystyrene sulfonate

*Electronically conductive polymers*

*Biological polymers*. e.g., enzymes & other proteins

*Blocking polymers*: formed from the monolayers, such as by oxidation of phenols, to produce impermeable layers and blocked or passivated surfaces

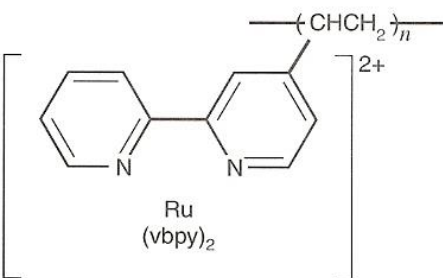
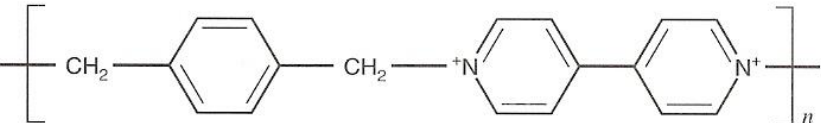
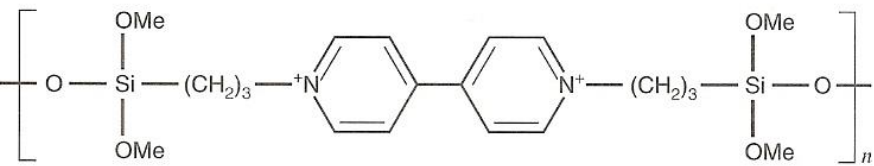
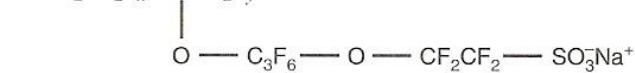
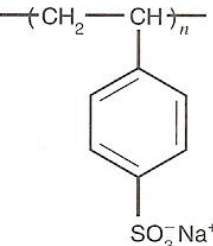
Name	Structure	Abbreviation
<i>Electroactive Polymers</i>		
Poly(vinylferrocene)	$\left[ \text{CH}_2 - \underset{\text{FeCp}_2}{\text{CH}} \right]_n$	PVF
Poly[Ru(vbpy) <sub>3</sub> <sup>2+</sup> ] <sup>b</sup>		
Poly(xylylviologen)		
Polymerized viologen organosilane		PQ <sup>2+</sup>
<i>Ion-exchange Polymers (Polyelectrolytes)</i>		
Nafion	$\left[ (\text{CF}_2\text{CF}_2)_x (\text{CF}_2\text{CF}_2)_y \right]$ 	NAF
Poly(styrenesulfonate)	$\left[ \text{CH}_2 - \underset{\text{SO}_3^- \text{Na}^+}{\text{CH}} \right]_n$ 	PSS

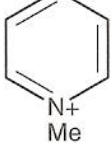
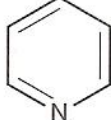
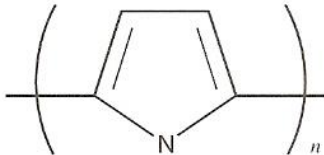
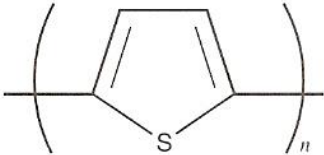
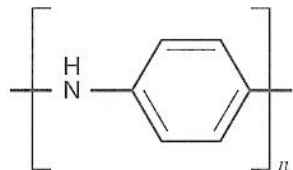
Name	Structure	Abbreviation
<i>Ion-exchange Polymers (Polyelectrolytes)</i>		
Quaternized poly (4-vinylpyridinium)	$\left( \text{CH}_2 - \underset{\text{C}_5\text{H}_4\text{N}^+\text{Me}}{\text{CH}} \right)_n$ 	QPVP
<i>Coordinating Polymer</i>		
Poly(4-vinylpyridine)	$\left( \text{CH}_2 - \underset{\text{C}_5\text{H}_4\text{N}}{\text{CH}} \right)_n$ 	PVP
<i>Electronically Conducting Polymers<sup>c</sup></i>		
Polypyrrole		PP
Polythiophene		PT
Polyaniline		PANI

## (b) Preparation

Polymer films on an electrode surface from solution or either the polymer or the monomer

Dissolved polymer: cast or dip coating, spin coating, electrodeposition, covalent attachment via functional groups

From monomer to films by thermal, electrochemical, plasma, or photochemical polymerization

## **Inorganic films**

### (a) Metal oxides

By anodization of metal electrodes.

e.g.,  $\text{Al}_2\text{O}_3$  on Al anode in  $\text{H}_3\text{PO}_4$  solution, Ti, W, Ta oxides

Film thickness can be controlled by the applied potential & anodization time

By CVD, vacuum evaporation, sputtering, deposition from colloidal solution

e.g., metallic polyanionic species (e.g., of W, Mo, V): electrocatalysis

### (b) Clays and zeolites

High stability & low cost, catalytic properties



### (c) Transition-metal hexacyanides

- Thin films of materials such as Prussian Blue (PB) ( a lattice of ferric ferrocyanide)  
→ deposited by electrochemical reduction in a solution of  $\text{FeCl}_3$  &  $\text{K}_3\text{Fe}(\text{CN})_6$   
→ blue film,  $\text{KFe}^{\text{III}}\text{Fe}^{\text{II}}(\text{CN})_6$  can be oxidized in a KCl solution to form  $\text{Fe}^{\text{III}}\text{Fe}^{\text{III}}(\text{CN})_6$  (Berlin Green) and reduced to form  $\text{K}_2\text{Fe}^{\text{II}}\text{Fe}^{\text{II}}(\text{CN})_6$  (Everitt's salt)  
→ PB electrodes show electrocatalytic properties (e.g., for the reduction of oxygen) & color change (for electrochromic applications)

### **Biological related materials**

Immobilization of a biologically sensitive coating (e.g., an enzyme, antibody, DNA) which can interact with (“recognize”) a target analyte, and produce an electrochemically detectable signal → biosensors applications

Bacteria and tissue

Immobilization: permeable polymer membrane, entrapment in a gel, encapsulation, adsorption, covalent linkage

### **Composite and multilayer assemblies**

Multiple films of different polymers (e.g., bilayer structures)

Metal films on a polymer layer (sandwich structures)

Multiple conductive substrates under the polymer film (electrode arrays)

Intermixed films of ionic and electronic conductor (biconductive layers)

Polymer layers with porous metal or minigrad supports (solid polymer electrolyte or ion-gate structures)

Porous metal films (e.g., Au or Pt) can be deposited on free-standing polymer membranes or on polymer films on an electrode surface by chemical reduction or by evaporation in vacuum

e.g., Porous Pt on Nafion from  $\text{PtCl}_6^{2-}$  & reducing agent (e.g., hydrazine)

→ fuel cell etc

(a) Sandwich electrode, (b) array electrode, (c) microelectrode, (d,e) bilayer electrode, (f) ion-gate electrode

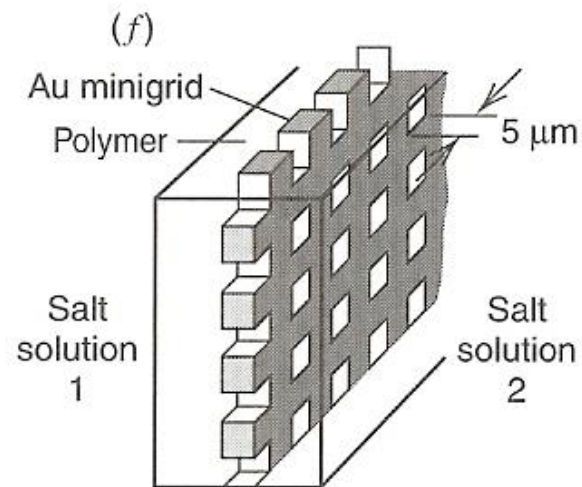
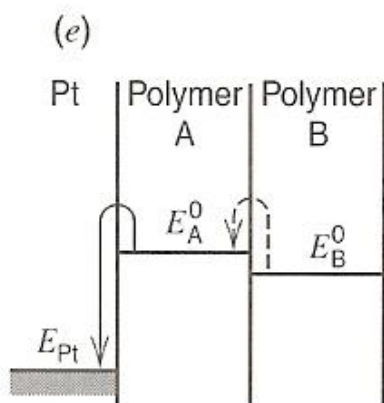
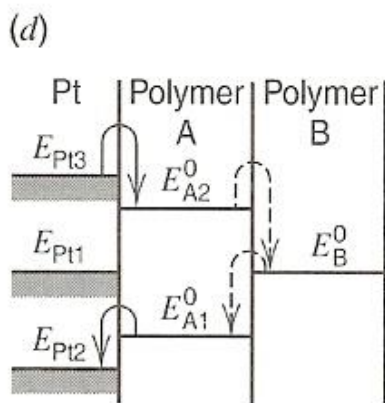
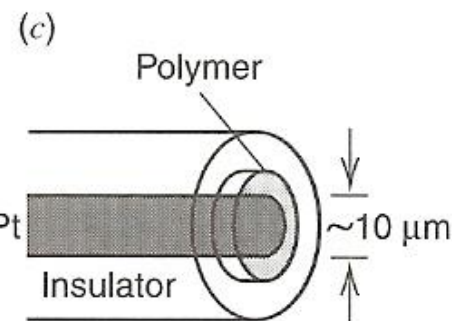
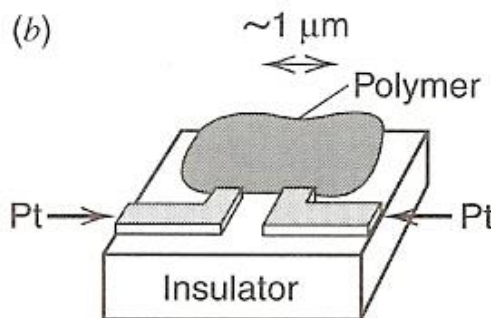
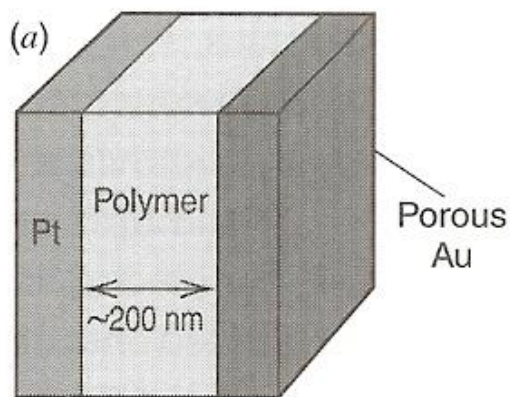

# cf. Voltammetry

## Introduction

Most widely used technique

Applying a continuously time-varying potential → working electrode

- oxidation/reduction reactions of electroactive species
- adsorption of species
- capacitive current due to double layer charging
- mechanisms of reactions
- identification of species
- quantitative analysis of reaction rates
- determination of rate constants

Two forms: linear sweep voltammetry(LSV) & cyclic voltammetry(CV)

# Potential sweep method

## Linear sweep voltammetry (LSV)

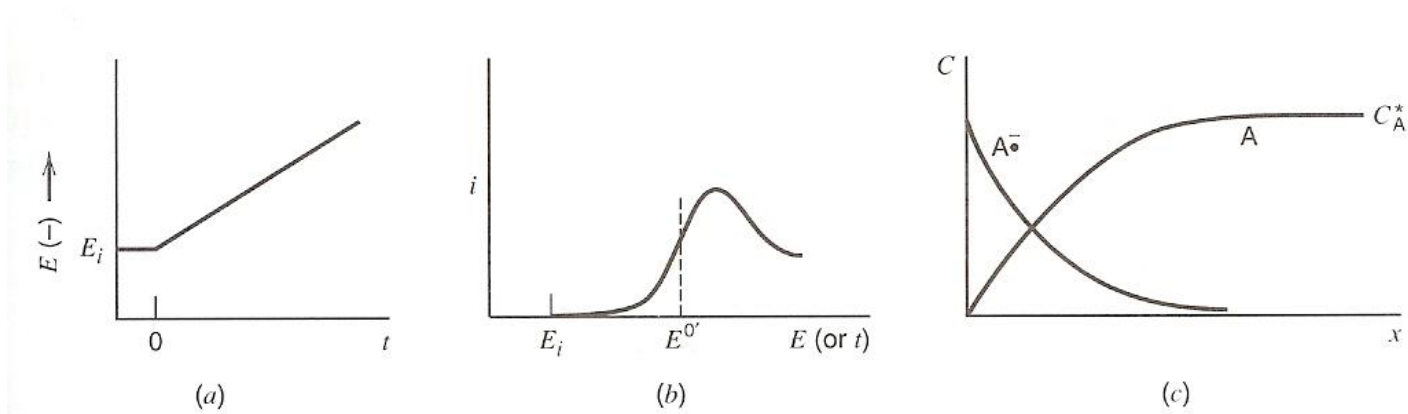

## Cyclic voltammetry (CV)

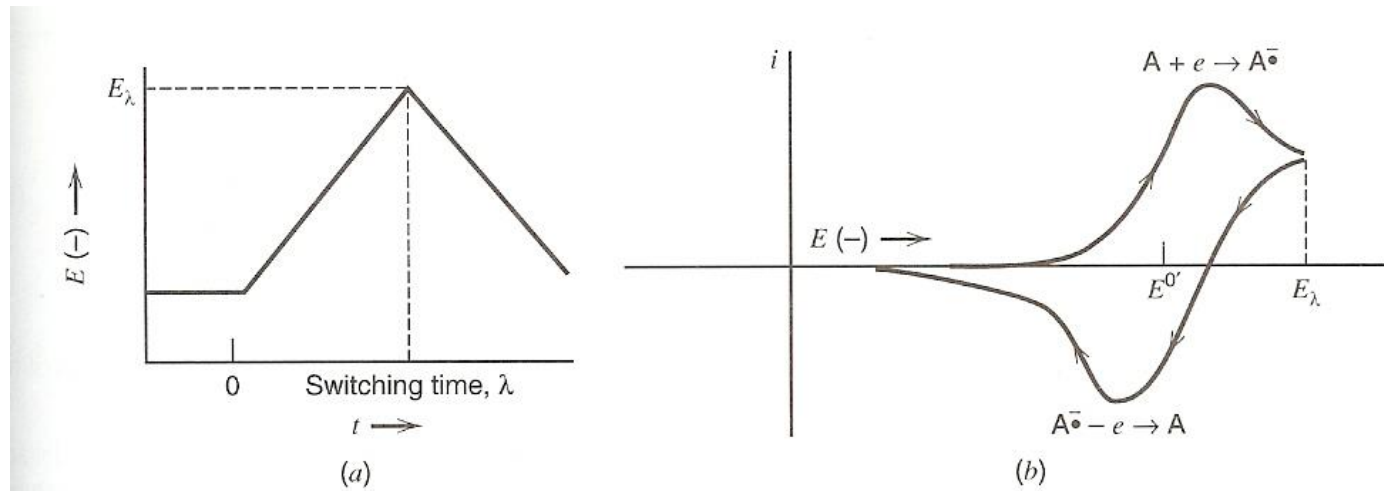

## Experimental

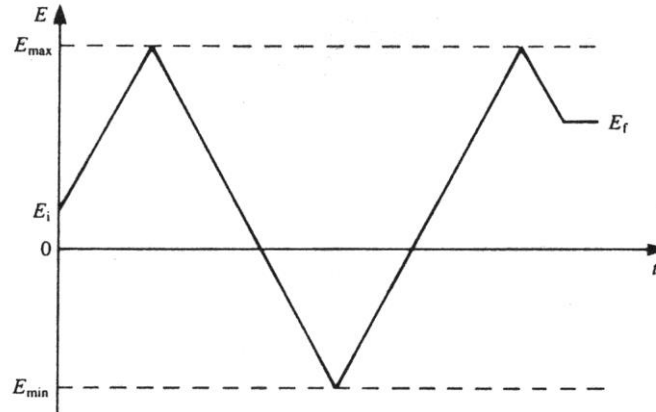

*Variation of applied potential with time in cyclic voltammetry*

### Parameters

- The initial potential,  $E_i$
- The initial sweep direction
- The sweep rate,  $v$
- The maximum potential,  $E_{\max}$
- The minimum potential,  $E_{\min}$
- The final potential,  $E_f$

Total current: faradaic,  $I_f$  (due to electrode reaction) +  $I_c$  (double layer capacitive)

$$I = I_c + I_f = C_d(dE/dt) + I_f = vC_d + I_f$$

$$I_c \propto v$$

$I_f \propto v^{1/2} \rightarrow$  capacitive current must be subtracted for very high sweep rate

Shape and position of voltammetric waves by rate  $v$

Sweep rate  $\uparrow \rightarrow$  less time to reach equilibrium at the electrode surface

### Experimental

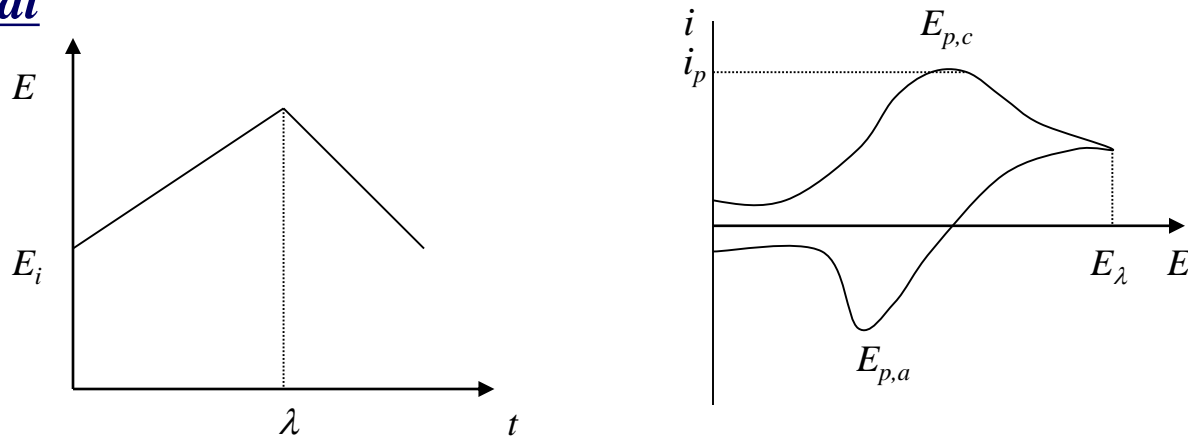

## Reversible system

Only O present, reversible, planar electrode, linear diffusion

$$E = E^{0'} + (RT/nF)\ln[C_O(0, t)/C_R(0, t)]$$

$$C_O(0, t)/C_R(0, t) = \exp[(nF/RT)(E - E^{0'})]$$

$$E = E_i - vt$$

$$I = -nFAC_O^*(\pi D_O \sigma)^{1/2} \chi(\sigma t)$$

where  $\sigma = (nF/RT)v$

$$I \propto C_O^*, v^{1/2}$$

$n(E - E_{1/2})$  vs.  $\pi^{1/2} \chi(\sigma t)$ , dimensionless

where  $E_{1/2} = E^{0'} + (nF/RT)\ln(D_R/D_O)^{1/2}$



**Table 9.1.** Values of the current functions  $\pi^{1/2}\chi(\sigma)$  (planar electrode) and  $\phi(\sigma)$  (spherical correction)<sup>a</sup> for linear sweep voltammetry and reversible charge transfer reaction  $O + ne^- \rightarrow R^{\ominus}$ .

$n(E - E_{1/2}^r)/\text{mV}$	$\pi^{1/2}\chi(\sigma)$	$\phi(\sigma)$	$n(E - E_{1/2}^r)/\text{mV}$	$\pi^{1/2}\chi(\sigma)$	$\phi(\sigma)$
120	0.009	0.008	-5	0.400	0.548
100	0.020	0.019	-10	0.418	0.596
80	0.042	0.041	-15	0.432	0.641
60	0.084	0.087	-20	0.441	0.685
50	0.117	0.124	-25	0.445	0.725
45	0.138	0.146	-28.50	0.4463	0.7516
40	0.160	0.173	-30	0.446	0.763
35	0.185	0.208	-35	0.443	0.796
30	0.211	0.236	-40	0.438	0.826
25	0.240	0.273	-50	0.421	0.875
20	0.269	0.314	-60	0.399	0.912
15	0.298	0.357	-80	0.353	0.957
10	0.328	0.403	-100	0.312	0.980
5	0.355	0.451	-120	0.280	0.991
0	0.380	0.499	-150	0.245	0.997

<sup>a</sup> See Section 9.4: at spherical electrodes,  $I = I(\text{planar}) + I(\text{spherical correction})$ .

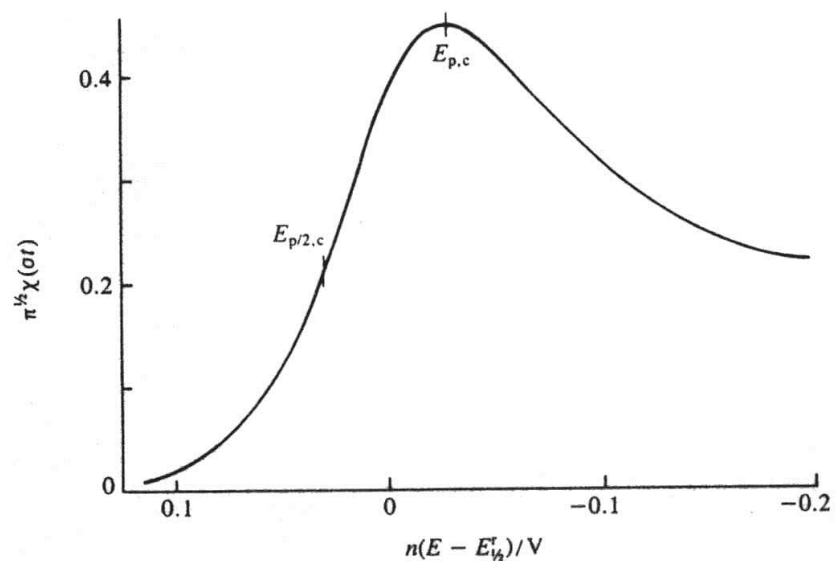

*Normalized linear sweep voltammogram for a reversible reduction at a planar electrode*

$$E_{p,c} - E_{1/2} = -28.8/n, \text{ mV}$$

$$E_{p/2,c} - E_{1/2} = -28.0/n, \text{ mV} \quad \text{where } E_{p/2,c} \text{ at } I = I_{p/2,c}$$

$$|E_{p,c} - E_{p/2,c}| = 56.6/n, \text{ mV}$$

$$I_{p,c} = -2.69 \times 10^5 n^{3/2} A D_O^{1/2} v^{1/2} C_O^*$$

Where A;cm<sup>2</sup>, D<sub>O</sub>;cm<sup>2</sup>s<sup>-1</sup>, C<sub>O</sub><sup>\*</sup>;molcm<sup>-3</sup>, v;Vs<sup>-1</sup>

$$I_p \propto v^{1/2}$$

E<sub>p</sub> independent of v

Invert scan direction;

$$E_{p,a} - E_{p,c} = 57/n, \text{ mV}$$

$$|I_{p,a}/I_{p,c}| = 1$$

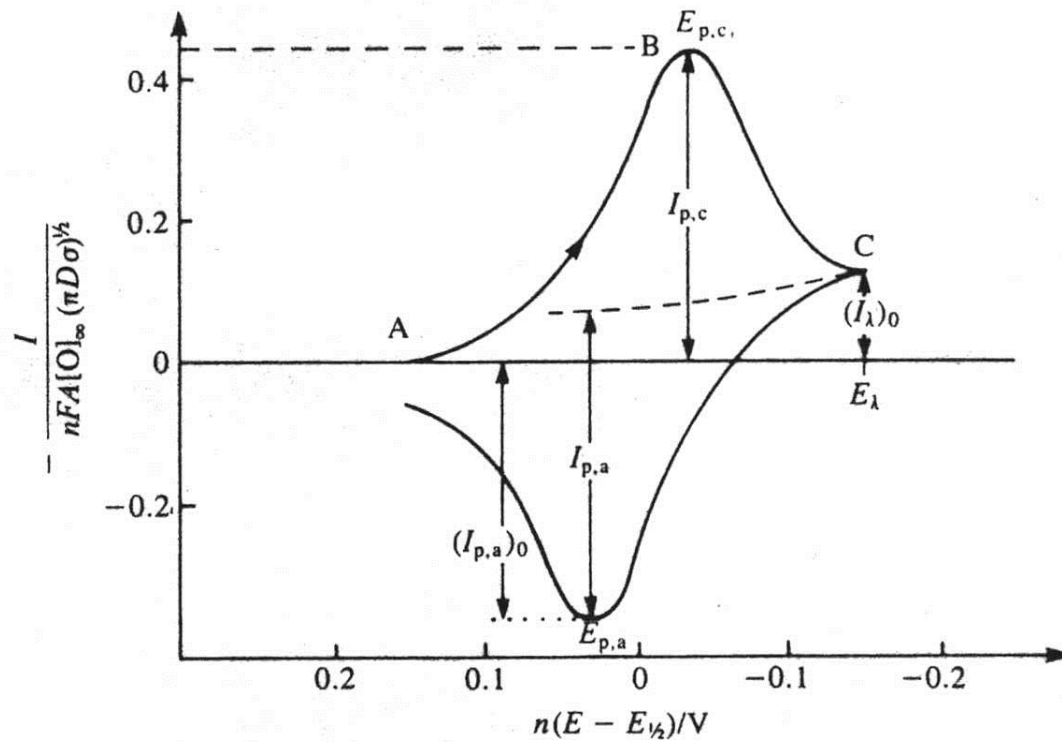

*Cyclic voltammogram for a reversible system*

## Irreversible system



$$K_c = k^0 \exp[(-\alpha n' F/RT)(E_i - E^{0'})]$$

$n'$ ; # of electrons transferred in the rate determining step

$$I_p = -2.99 \times 10^5 n (\alpha n')^{1/2} A C_O^* D_O^{1/2} \nu^{1/2}$$

$$I_p \propto \nu^{1/2}$$

$$|E_p - E_{p/2}| = 47.7/\alpha n', \text{ mV}$$

e.g.,  $\alpha = 0.5$ ,  $n' = 1 \rightarrow$  much more spread out

$$E_p = \text{const} - (2.3RT/\alpha n' F) \log \nu \quad \text{or} \quad |dE_p/d\log \nu| = 30/\alpha n', \text{ mV}$$

$E_p$  depending on sweep rate

The peaks are broader and lower

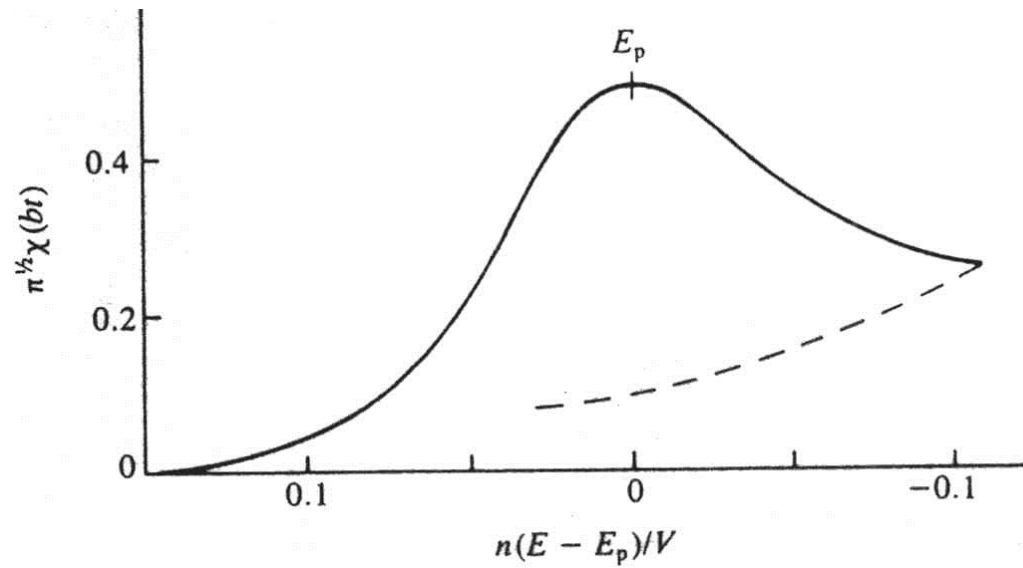

*Linear sweep voltammogram for an irreversible system*

## Quasi-reversible system

Kinetics +oxidation/reduction

$v \uparrow \rightarrow$  irreversibility  $\uparrow$ , peak current  $\downarrow$ , separation anodic and cathodic peaks  $\uparrow$

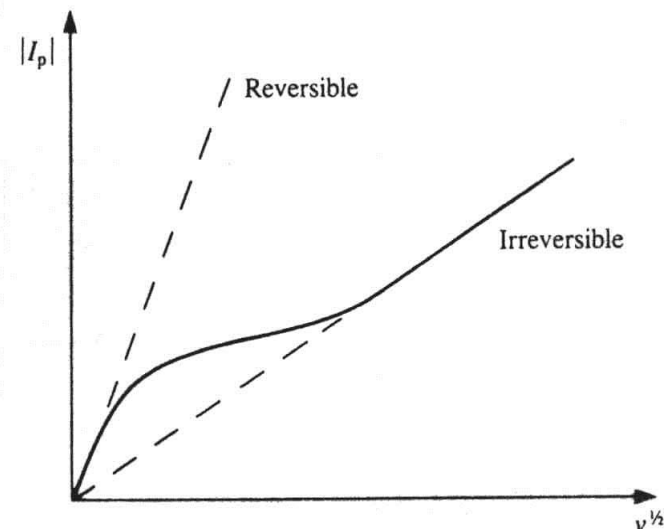
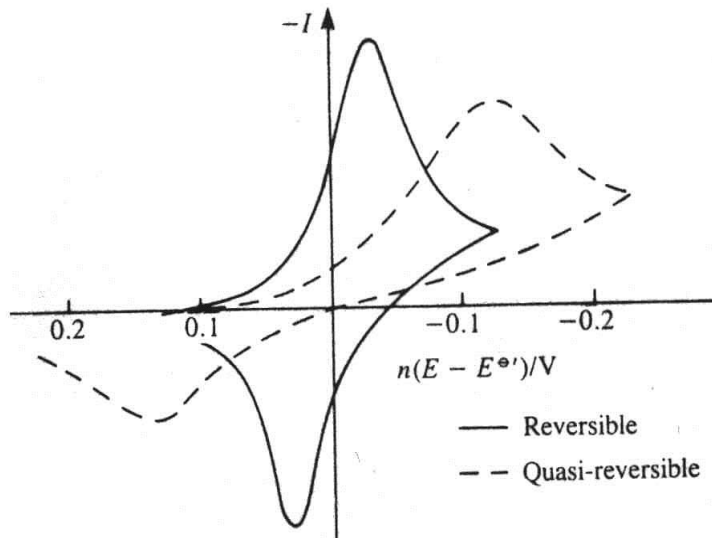

Electric charge (=amount of electricity)  $Q$  (unit: Coulomb, C), time  $t$   
Electric current (unit: ampere (A)):

$$I = dQ/dt$$

$$Q = \int Idt$$

Current density (unit: A/m<sup>2</sup>):  $i = I/A$ ,  
A: surface of area

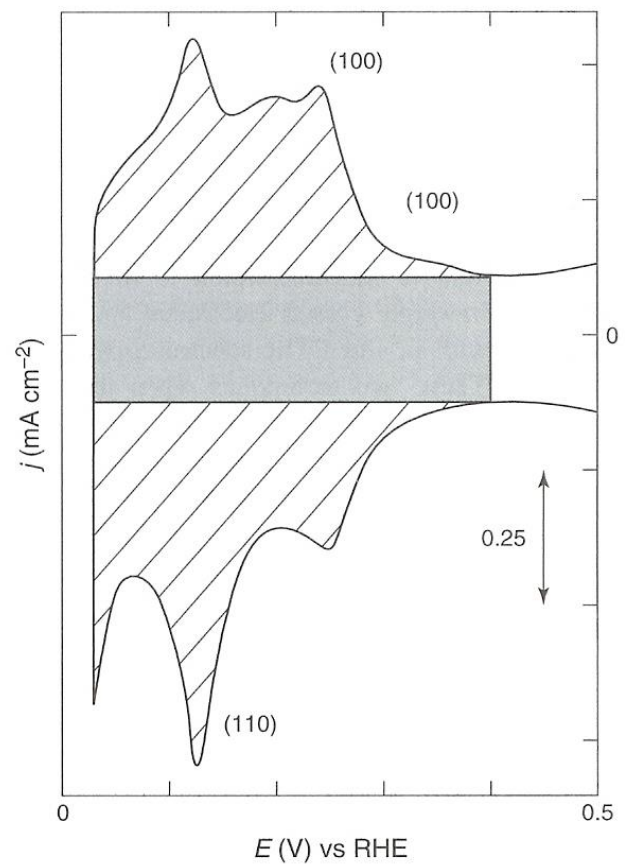
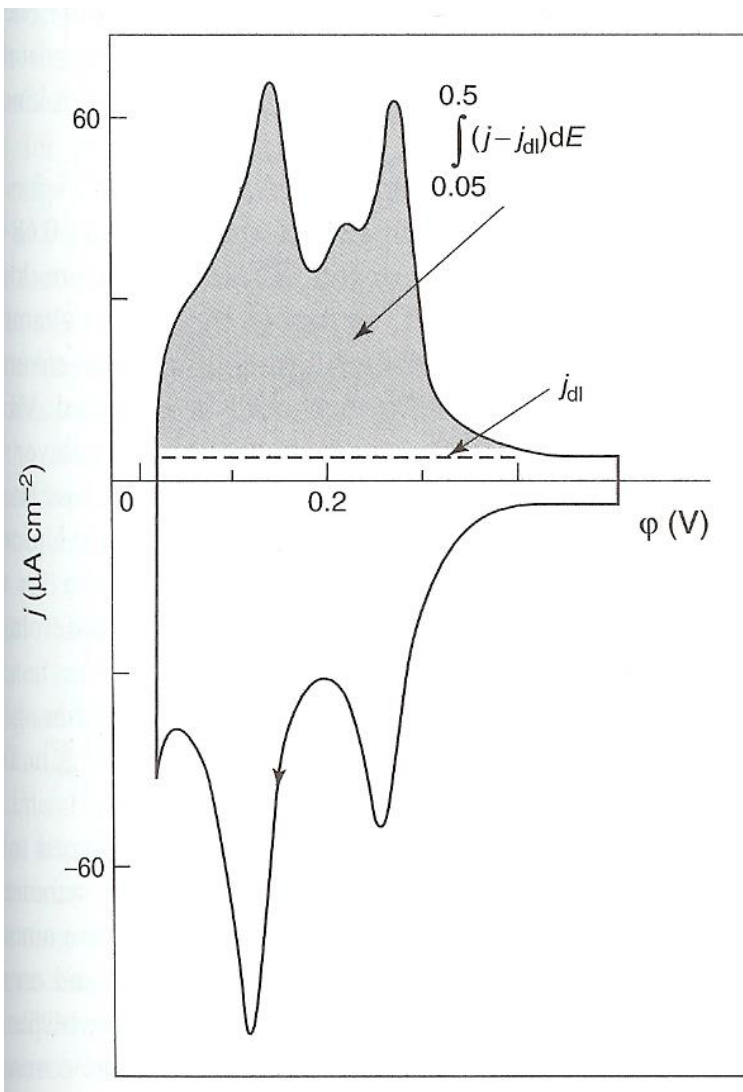

**Figure 5.** Cyclic voltammograms of Pt/Vulcan dispersed electrode with a loading of  $28 \mu\text{g}_{\text{Pt}} \text{cm}^{-2}$ . The gray rectangle is the estimated double layer charge and the Vulcan capacitance used to correct the charge due to the hydrogen adsorption–desorption. The solution was  $0.5\text{M H}_2\text{SO}_4$  at  $25^\circ\text{C}$  and the speed rate is  $0.02 \text{V s}^{-1}$ . (Reproduced from Schmidt *et al.* (1998)<sup>[39]</sup> by permission of the Electrochemical Society Inc.)

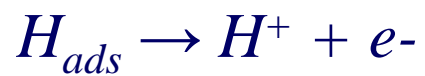



# Electrochemical responses of adsorbed monolayers

## Principles

Effect of  $O + ne \rightarrow R$  by the adsorption of O or R

Net reaction involves the electrolysis of diffusing O as well as O adsorbed on the electrode, to produce R that diffuse away and R remains adsorbed

General flux equation

$$D_O[\partial C_O(x,t)/\partial x]_{x=0} - \partial \Gamma_O(t)/\partial t = -[D_R(\partial C_R(x,t)/\partial x)_{x=0} - \partial \Gamma_R(t)/\partial t] = i/nFA$$

where  $\Gamma_O(t)$  &  $\Gamma_R(t)$  are the amounts of O & R adsorbed at time t (mol/cm<sup>2</sup>)  
→  $\Gamma$  vs. C equation required

Assume Langmuir isotherm ((13.5.9), (13.5.10))

$$\Gamma_O(t) = \beta_O \Gamma_{O,s} C_O(0,t) / [1 + \beta_O C_O(0,t) + \beta_R C_R(0,t)]$$

$$\Gamma_R(t) = \beta_R \Gamma_{R,s} C_R(0,t) / [1 + \beta_O C_O(0,t) + \beta_R C_R(0,t)]$$

Initial conditions

$$(t = 0) \quad \Gamma_O = \Gamma_O^* \quad \Gamma_R = 0$$

## Cyclic voltammetry: only adsorbed O & R electroactive- nernstian reaction

Assume that the contribution to the current from dissolved O is negligible

$$-\partial\Gamma_{\text{O}}(t)/\partial t = -\partial\Gamma_{\text{R}}(t)/\partial t = i/nFA$$

$$\Gamma_{\text{O}}(t) + \Gamma_{\text{R}}(t) = \Gamma_{\text{O}}^*$$

$$\Gamma_{\text{O}}(t)/\Gamma_{\text{R}}(t) = \beta_{\text{O}}\Gamma_{\text{O},s}C_{\text{O}}(0,t)/\beta_{\text{R}}\Gamma_{\text{R},s}C_{\text{R}}(0,t) = b_{\text{O}}C_{\text{O}}(0,t)/b_{\text{R}}C_{\text{R}}(0,t)$$

With  $b_{\text{O}} = \beta_{\text{O}}\Gamma_{\text{O},s}$ ,  $b_{\text{R}} = \beta_{\text{R}}\Gamma_{\text{R},s}$

If the rxn is nernstian

$$C_{\text{O}}(0,t)/C_{\text{R}}(0,t) = \exp[(nF/RT)(E - E^{0'})]$$

$$\rightarrow \Gamma_{\text{O}}(t)/\Gamma_{\text{R}}(t) = (b_{\text{O}}/b_{\text{R}})\exp[(nF/RT)(E - E^{0'})]$$

$$i/nFA = -\partial\Gamma_{\text{O}}(t)/\partial t = [\partial\Gamma_{\text{O}}(t)/\partial E]v$$

$$E = E_i - vt$$

i-E curve

$$i = (n^2F^2/RT)(vA\Gamma_{\text{O}}^*(b_{\text{O}}/b_{\text{R}})\exp[(nF/RT)(E-E^{0'})] / \{1 + (b_{\text{O}}/b_{\text{R}})\exp[(nF/RT)(E-E^{0'})]\}^2)$$

cf. similar with thin-layer cell (Ch.11)

The peak current

$$i_p = (n^2 F^2 / 4RT) v A \Gamma_O^*$$

The peak potential

$$E_p = E^{0'} - (RT/nF) \ln(b_O/b_R) = E_a^{0'}$$

Peak current is proportional to v (in contrast  $v^{1/2}$  dependence for diffusing species)

Proportionality betwn  $i$  &  $v$  = purely capacitive current ((6.2.25))

→ adsorption in terms of “pseudocapacitance”

→ reduction area = charge required for full reduction of the layer:  $nFA\Gamma_O^*$

Anodic wave on scan reversal: mirror of the cathodic wave

For ideal nernstian rxn under Langmuir isotherm:  $E_{pa} = E_{pc}$

→ total width at half-height of either cathodic or anodic wave

$$\Delta E_{p,1/2} = 3.53(RT/nF) = 90.6/n \text{ mV (25}^\circ\text{C)}$$

Location of  $E_p$  with respect to  $E^{0'}$  depend on the relative strength of adsorption of O & R → if  $b_O = b_R$ ,  $E_p = E^{0'}$

If O is adsorbed more strongly ( $b_O > b_R$ ), the wave displaced toward negative potentials (‘postwave’)

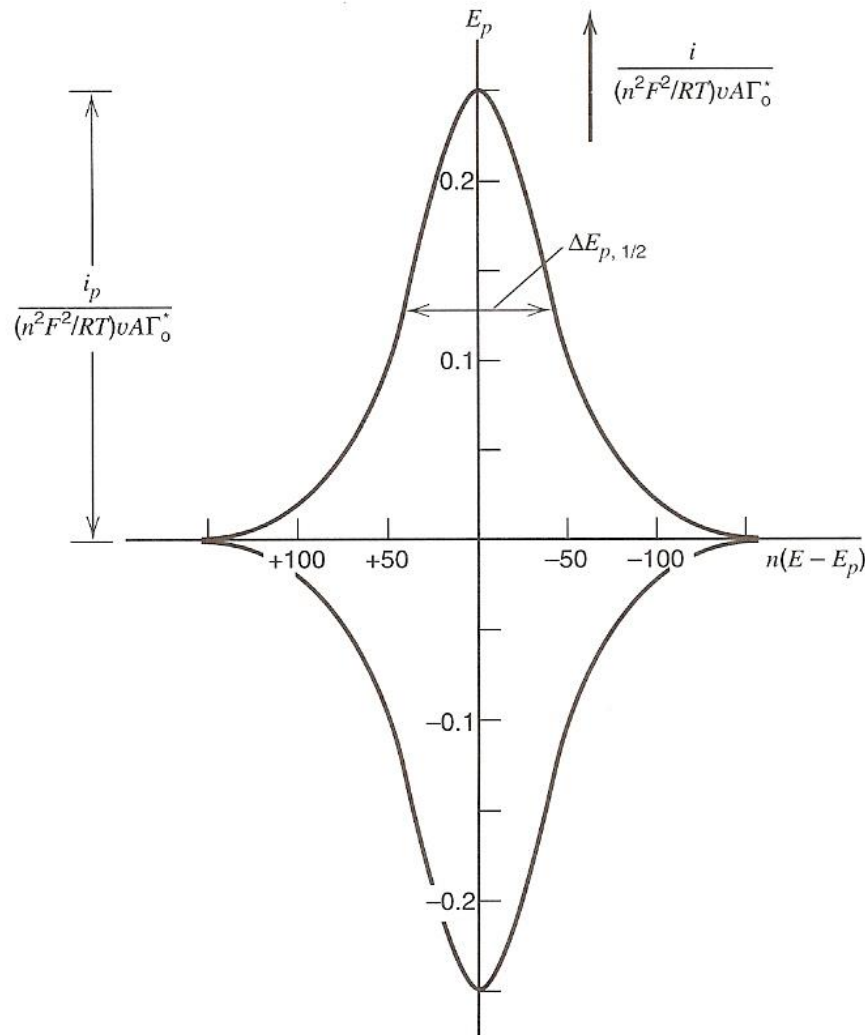

If R is adsorbed more strongly ( $b_O < b_R$ ), the wave displaced toward positive potentials (‘prewave’)

When lateral interactions exist between O & R in the film

→ the shape of i-E curve depends upon the energies of the interactions of O with O, R with R, O with R

If a Frumkin-type isotherm

$$\exp[(nF/RT)(E - E^{0'})] = (\theta_O/\theta_R)\exp[2v\theta_O(a_{OR} - a_O) + 2v\theta_R(a_R - a_{OR})]$$

where  $a_{OR}$ ,  $a_O$ , and  $a_R$ : O-R, O-O, and R-R interaction parameters ( $a_i > 0$  for an attractive interaction,  $a_i < 0$  for a repulsive one)

$v$ : # of water molecules displaced from the surface by adsorption of one O or R

$\theta_O$  &  $\theta_R$ : fractional coverages of O & R

$$i = (n^2 F^2 A v \Gamma_O^* / RT) \{ \theta_R (1 - \theta_R) / [1 - 2v g \theta_T \theta_R (1 - \theta_R)] \}$$

where  $\theta_T = \theta_O + \theta_R$ ,  $g = a_O + a_R - 2a_{OR}$ ,  $\Gamma_O^* = \Gamma_O + \Gamma_R$ ,  $\theta_i = \Gamma_i / \Gamma_O^*$

Potential variation arises through the variation of  $\theta_R$  with E

i-E curve shape is governed by the interaction parameter,  $vg\theta_T$

$vg\theta_T = 0$  (Langmuir form, Figure in previous page),  $\Delta E_{p,1/2} = 90.6/n$  (25°C)

When  $vg\theta_T > 0$ :  $\Delta E_{p,1/2} < 90.6/n$ , when  $vg\theta_T < 0$ ,  $\Delta E_{p,1/2} > 90.6/n$

Effect of interactions (Frumkin isotherm assumed):  
 $\nu g \theta_T$  values ( $0 \rightarrow$  same as the previous figure)

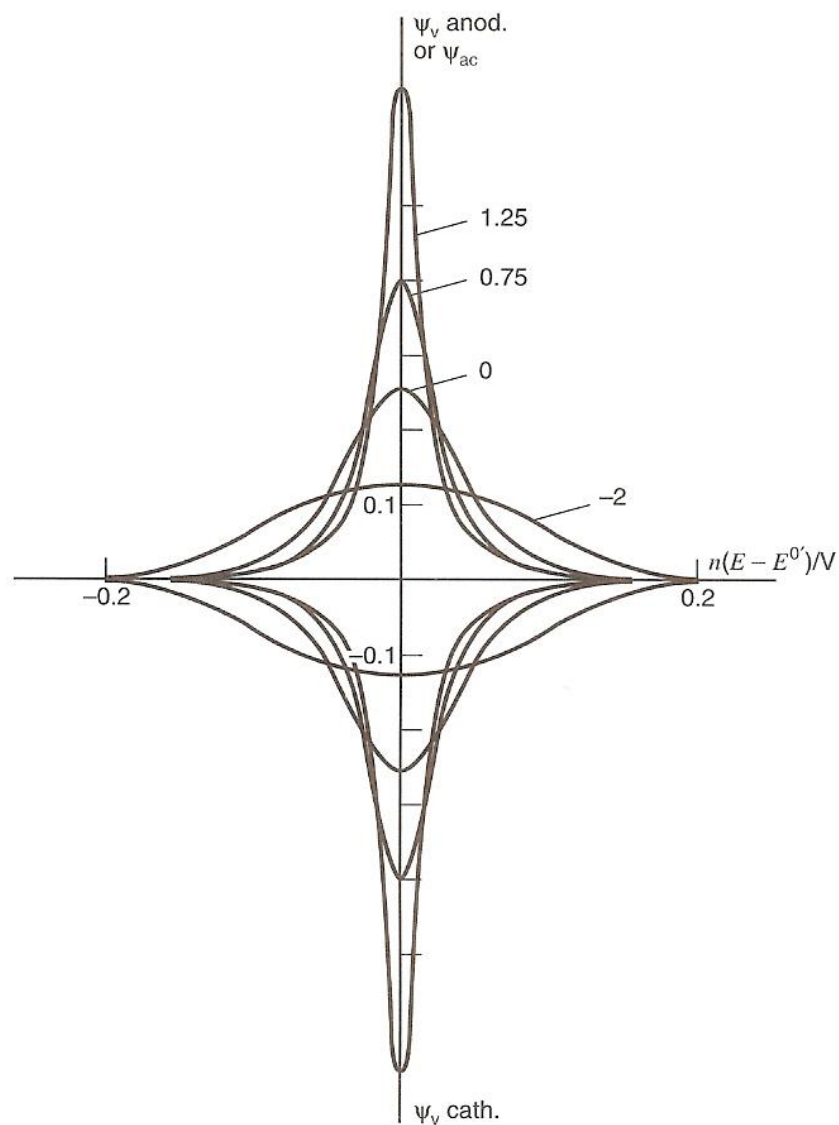

Experimental (solid line) vs. theoretical (dotted line)

Reduction & reoxidation of 9,10-phenanthrenequinone irreversibly adsorbed on carbon electrode ( $\Gamma_0 = 1.9 \times 10^{-10} \text{ mol/cm}^2$ )

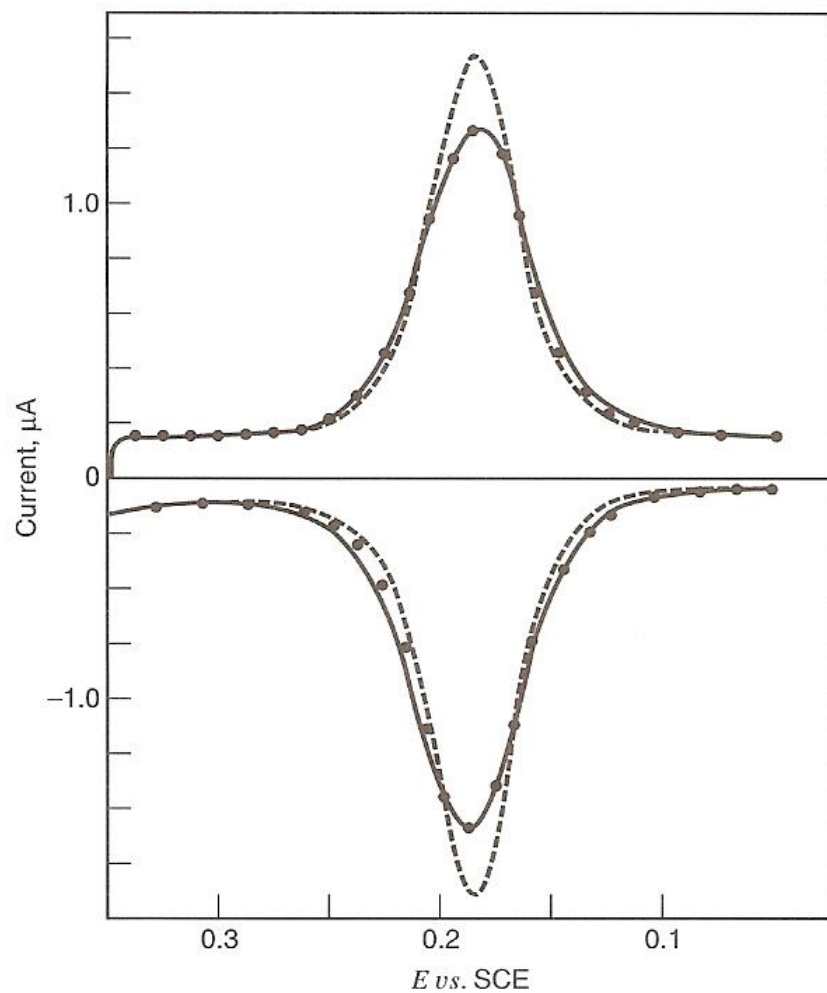

## Cyclic voltammetry: both dissolved & adsorbed species electroactive

Adsorption isotherms + diffusion equation

Consider only nernstian electron-transfer rxn case

**(a) Product (R) strongly adsorbed**

$\beta_O \rightarrow 0$  &  $\beta_R$  large (i.e.,  $\beta_R C^* \geq 100$ )

Initially  $C_O = C_O^*$ ,  $C_R = 0$ ,  $\Gamma_R^* = 0$

Variation of  $\beta_R$  with E

$$\beta_R = \beta_R^0 \exp[(\sigma_R nF/RT)(E - E_{1/2})]$$

where  $\sigma_R$ : parameter for  $\Delta G_i^0$  variation with E;  $\sigma_R = 0 \rightarrow \beta_R$  is independent of E

$\rightarrow$  prewave (or prepeak): same shape (sec (14.3.2))

$\rightarrow$  reduction of dissolved O to form adsorbed R

(at E more positive than diffusion-controlled wave

because free E adsorbed R easier than R in soln)

$\rightarrow$  then wave for reduction of dissolved O to dissolved R

(perturbed by the depletion of species O during reduction)

The larger  $\beta_R \rightarrow$  the more the prepeak precedes the diffusion peak



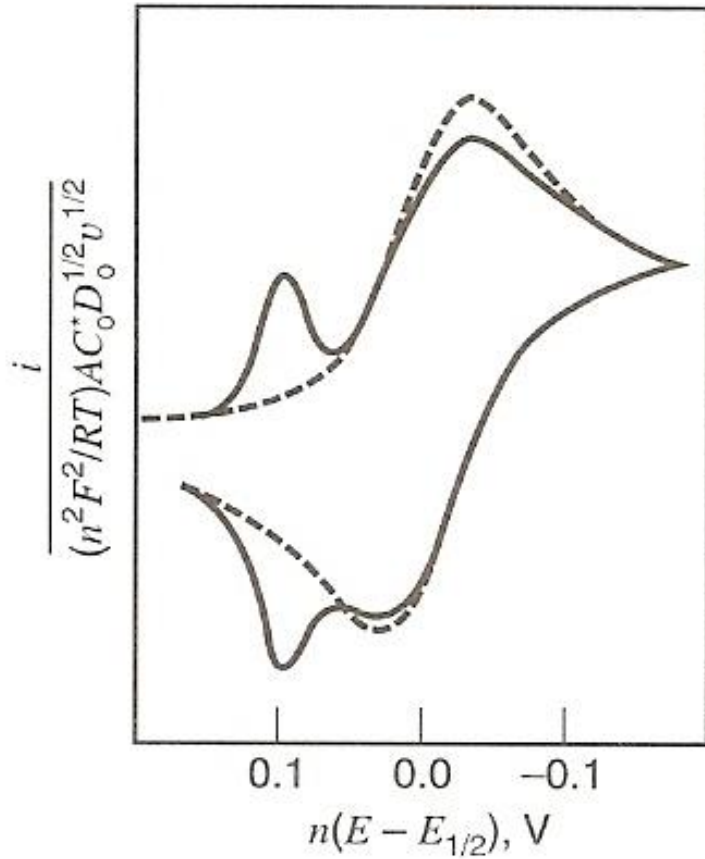

Dashed line:  
in the absence of adsorption

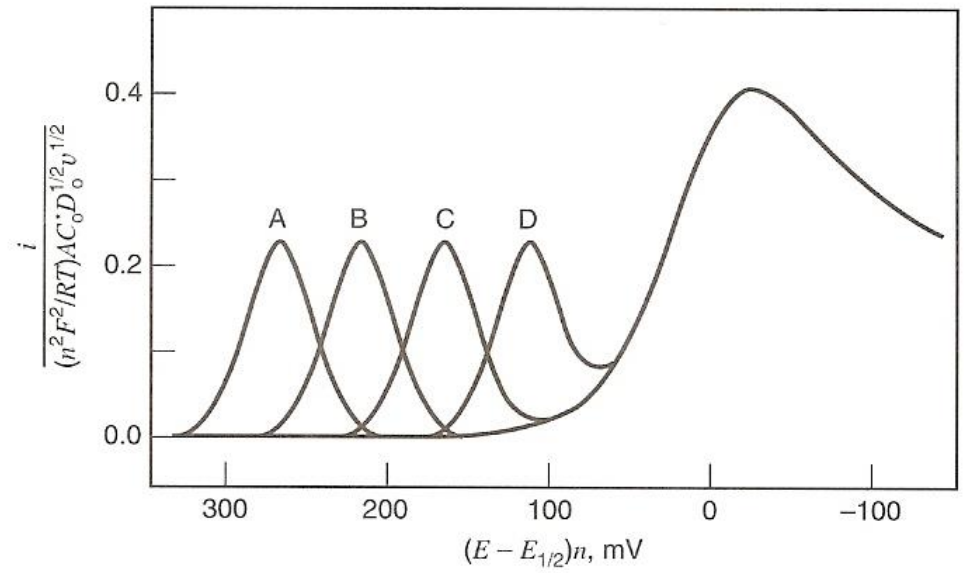

$\beta_R : A > B > C > D$

$(i_p)_{\text{ads}}$  increases with  $v$  &  $(i_p)_{\text{diff}}$  with  $v^{1/2} \rightarrow (i_p)_{\text{ads}}/(i_p)_{\text{diff}}$  increases with  $v^{1/2}$

Relative scan rate:  $A > B > C$  (64:16:1)

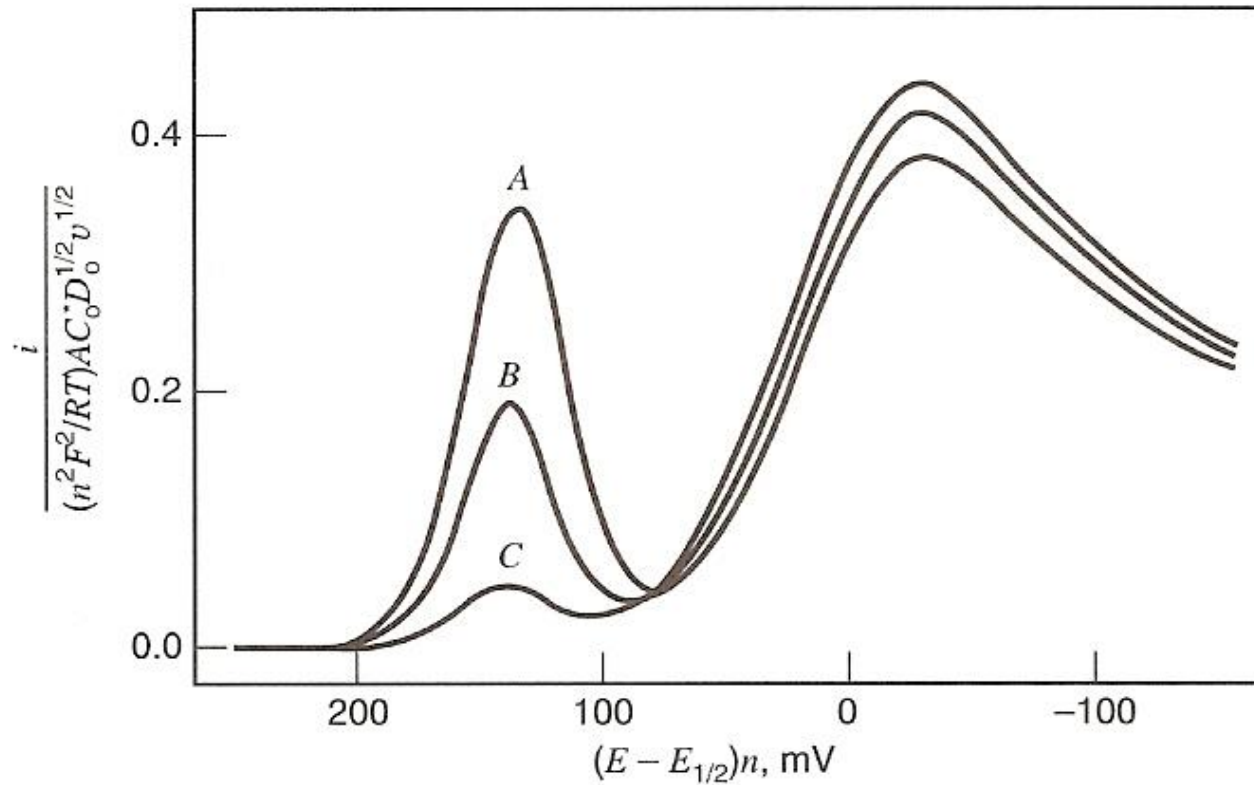

**(b) Reactant (O) strongly adsorbed ( $\beta_R \rightarrow 0$  &  $\beta_O$  large (i.e.,  $\beta_O C_O^* \geq 100$ )**  
*Postwave (or postpeak)* for the reduction of adsorbed O, following the peak for the diffusion-controlled reduction of O to R in solution

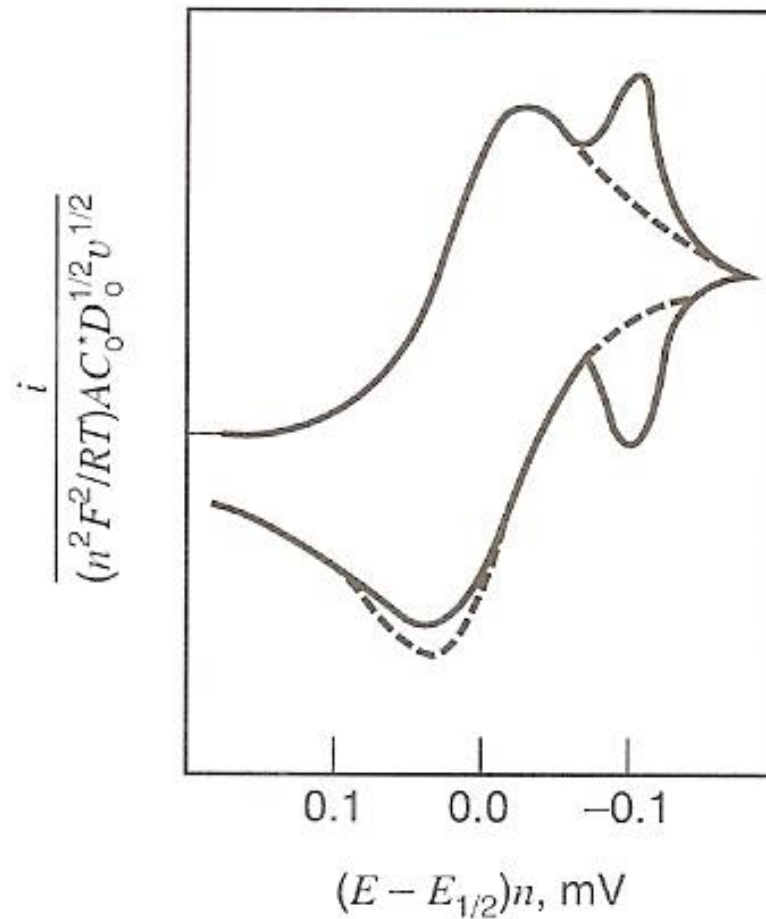

**(c) Reactant (O) weakly adsorbed ( $\beta_R \rightarrow 0$  &  $\beta_O C_O^* \leq 2$ )**

When adsorption is weak the difference in energies for reduction of adsorbed & dissolved O is small  $\rightarrow$  a separate postwave is not observed  $\rightarrow$  an increase in cathodic peak current because both adsorbed and diffusing O contribute to the current

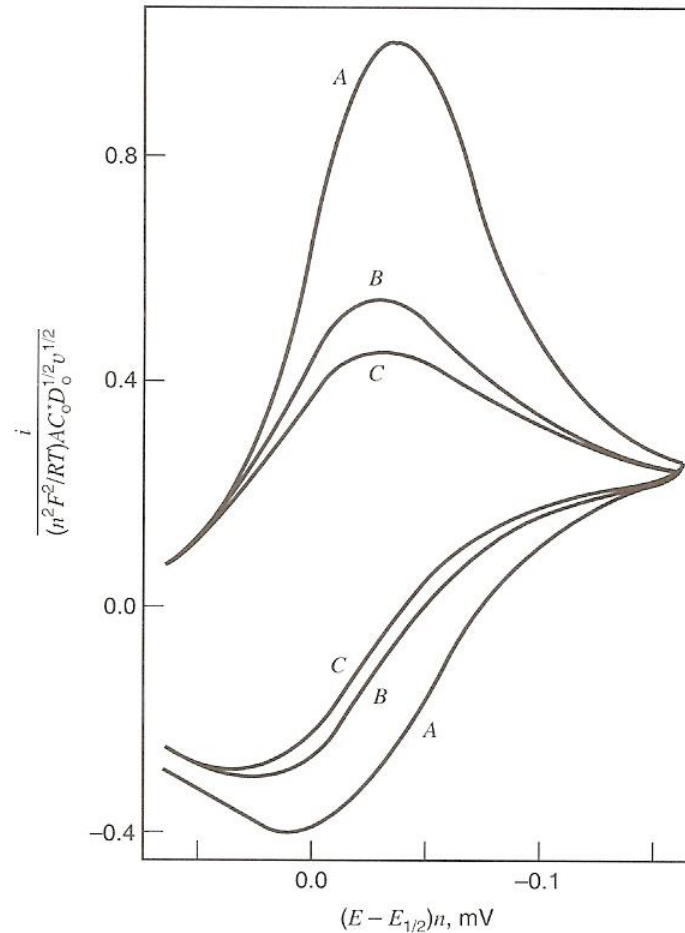

**(d) Product (R) weakly adsorbed ( $\beta_O \rightarrow 0$  &  $\beta_R C_O^* \leq 2$ )**

A separate prewave is not observed  $\rightarrow$  an increase in anodic peak current

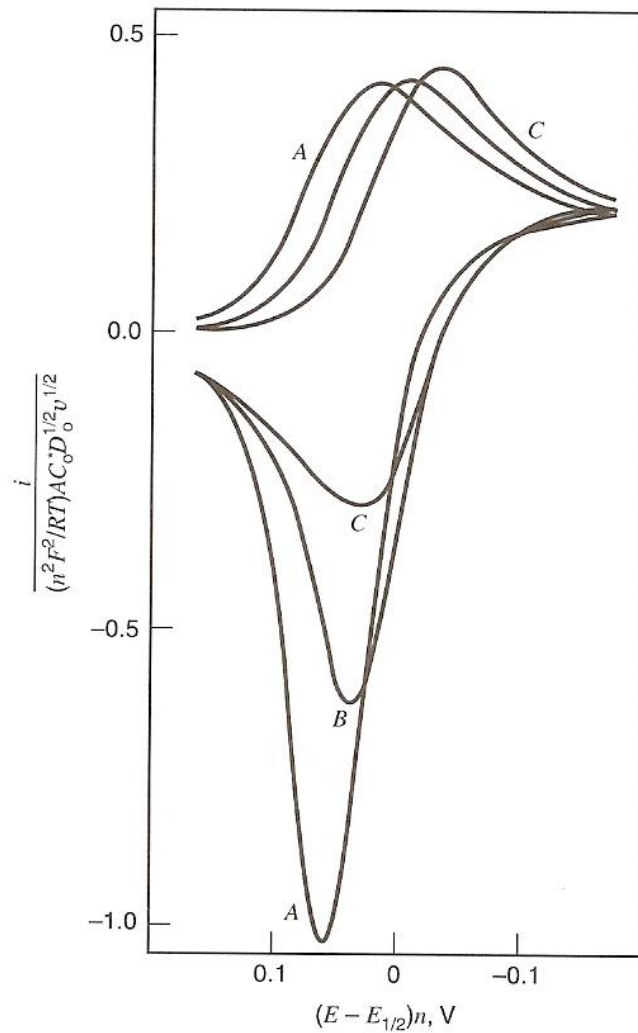

## Thin layer cell

Reversible: peak current  $\propto v$ , no separation between anodic and cathodic peaks, total symmetric  $E_p$

Irreversible:

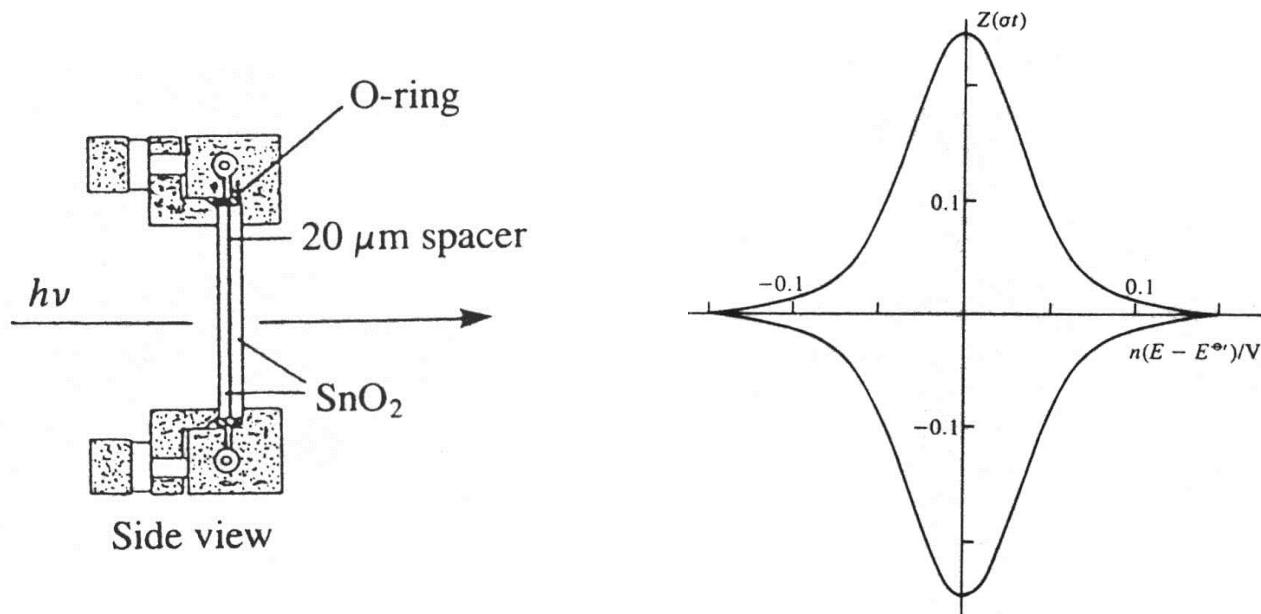

*Shape of the cyclic voltammogram obtained in a thin-layer cell for a reversible system*

## Overview of processes at modified electrodes

A: a species in solution

P: reducible substance in a film

(1) Heterogeneous e-transfer to P to produce the reduced form Q

(2) e-transfer from Q to another P in film (e diffusion or e hopping in film)

(3) e-transfer from Q to A at film/solution interface

(4) Penetration of A into the film

(5) Movement (mass transfer) of Q within the film

(6) Movement of A through a pinhole or channel

