



Week 10
기초공

457.308 Construction Methods and Equipment
Department of Civil and Environmental Engineering
Seoul National University

Prof. Seokho Chi

shchi@snu.ac.kr

건설환경공학부 35동 304호

Field Survey and Testing

- 기초 (foundation): 상부구조에서 오는 하중을 지반에 전달하는 부분
 - 얕은기초: 상부 구조의 하중을 기초 슬라브에서 지반에 직접 전달시키는 형태로 구조물 하중을 접지압(contact pressure)으로 지지하는 기초
 - 깊은기초: 구조물 하중을 선단지지력과 주변마찰력으로 지지하는 형태의 기초

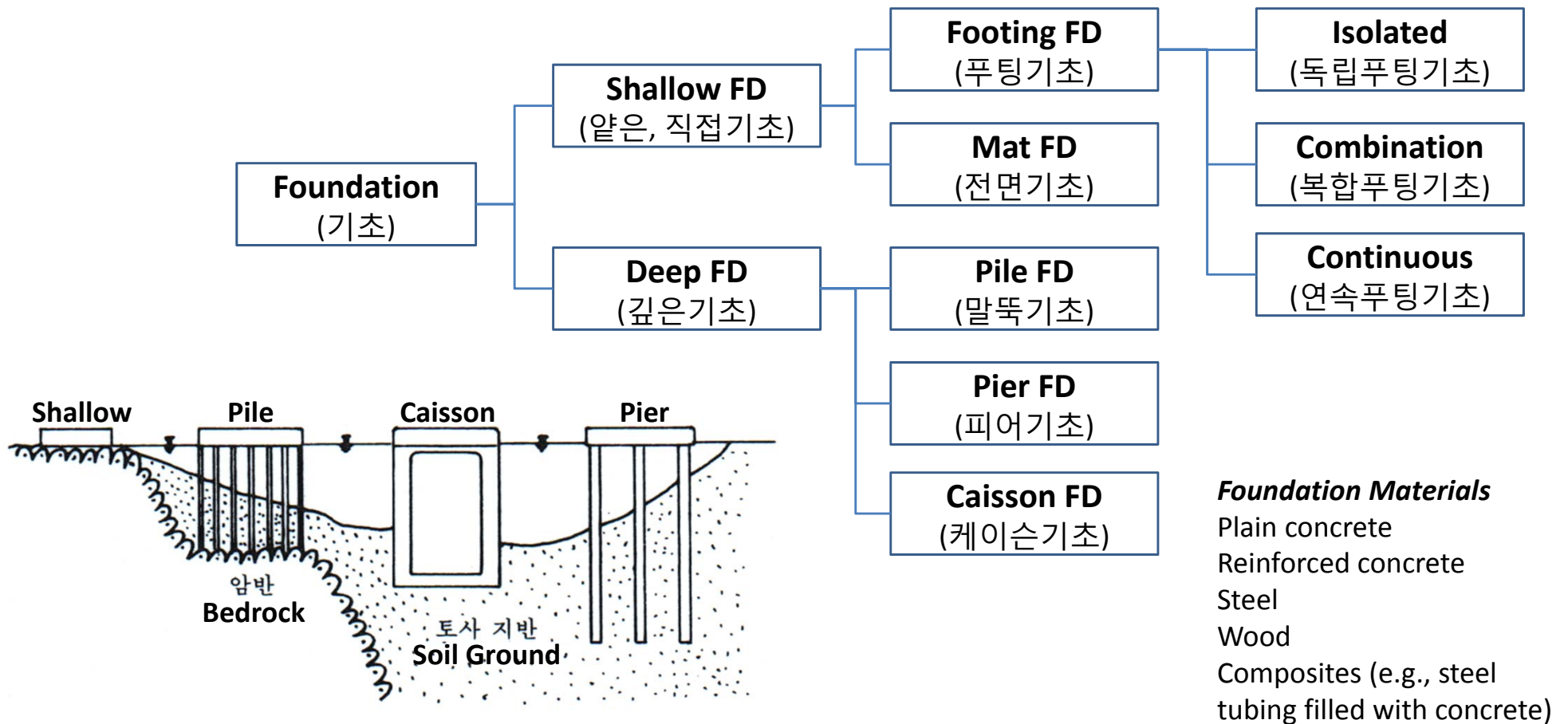

Field Survey and Testing

• 지반조사

– 예비조사

*Sounding: 로드 끝에 설치한 저항체를 땅속에 관입하여 관입, 회전, 인발 등의 저항으로 토층의 성질과 상태를 탐사하는 것

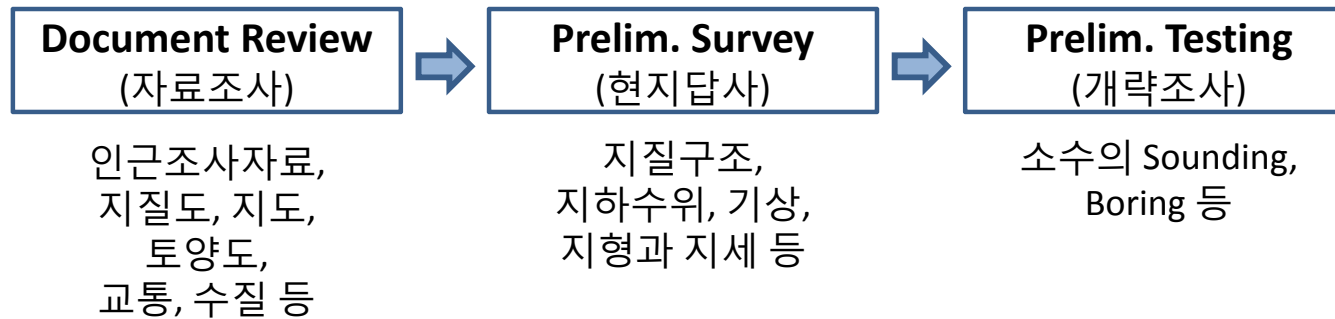

– 본조사

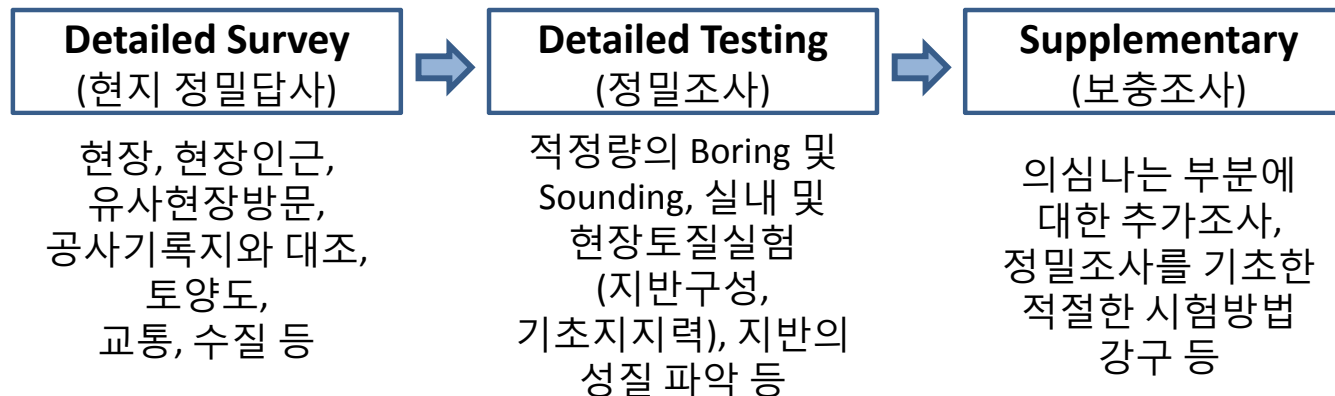

Field Survey and Testing

- 기초공법의 선정조건

- 기초는 상부 하중에 대하여 충분한 지지력을 가져야 한다.
- 기초는 최소 근입 깊이를 확보하여 지반의 습윤팽창, 건조수축, 동결, 지하수 변동, 파이핑, 인접공사 등의 영향을 받지 않아야 한다.
- 기초의 변형(침하, 부등침하, 회전)이 허용한계 이내에 있어야 하며 상부구조와 어울려야 한다.
- 기초는 구조물과 지반 시스템의 안정, 기초 바닥면의 활용에 대한 안정, 전도에 대한 안정, 지반의 전단파괴 즉 지지력에 대한 안정을 유지하여야 한다.
- 선정된 기초 공법은 경제적이고 기술적으로 시공 가능해야 하며 시공하는 동안 인접 구조물에 피해가 없어야 한다.

Field Survey and Testing

• 기초의 침하

- 지반의 압축이나 압밀에 의하여 발생하는 연직 변위
- 균등침하: 구조물의 모든 부분이 같이 침하, 구조물에 균열은 생기지 않고 연직 위치만 달라짐으로 크게 문제가 되지 않을 수도 있음
- 부등침하: 침하의 크기가 다른 침하, 구조물의 수명에 관한 심각한 문제로 발전될 수 있음
 - 침하한 기초의 양단을 연결한 가상선을 기준으로 측정된 침하량이 서로 상이 할 경우의 침하

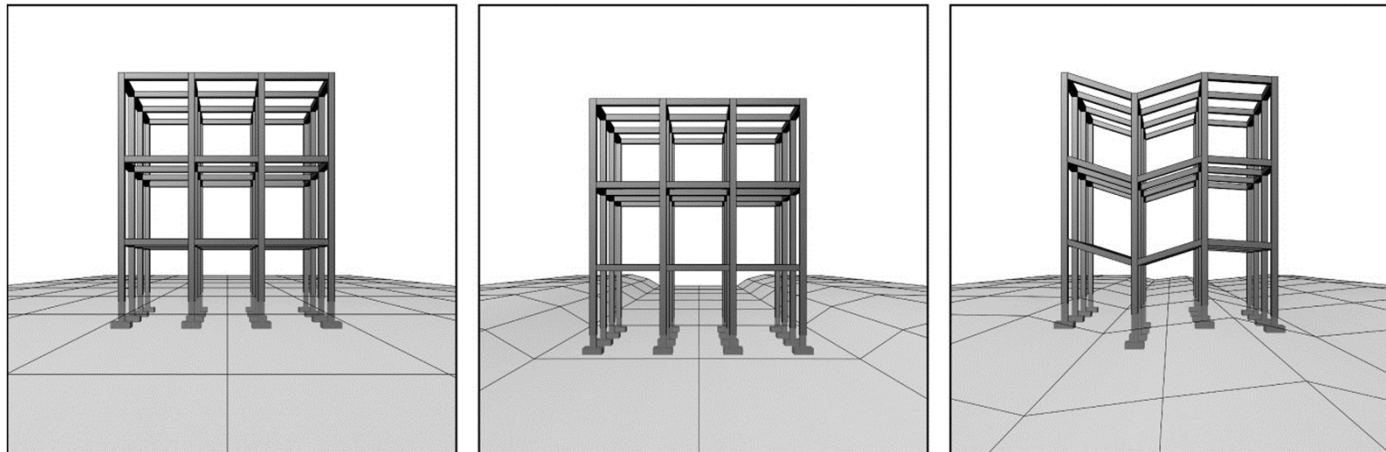

Field Survey and Testing

- 기초침하의 원인

- 구조물 하중에 의한 지중응력의 증가 (지반의 탄소성 변형)
- 지하수위 강하에 따른 지반 내 유효응력 증가
- 점성토 지반의 건조수축
- 함수비의 증가에 의한 지반 지지력의 약화
- 지반의 기초파괴
- 지하공동이나 지하매설관 등 지중 공간의 함몰
- 동상 후의 지반 연화에 의한 지반 지지력의 약화

Field Survey and Testing

• 침하의 종류

- 총침하량 (S) = 즉시침하량 (S_i) + 압밀침하량 (S_c) + 2차침하량 (S_s)
- 즉시침하량: 기초에 하중이 가해질 때의 지반 압축
- 압밀침하량: 시간이 지남에 따라 간극속의 물이 빠져 나가면서 지반의 체적이 감소되어 일어나는 침하
- 2차침하량: 유기질토나 점성토에서 Creep에 의한 2차 압밀에 의해 발생하는 압축침하

Consolidation(압밀): Soil compaction due to void water dry (간극수 배출)

Creep: Gradual downhill movement under the force of gravity after consolidation

Secondary consolidation: Soil compaction due to soil particle rearrangement caused by soil creep (cohesive soil 점성토, organic soil 유기질토)

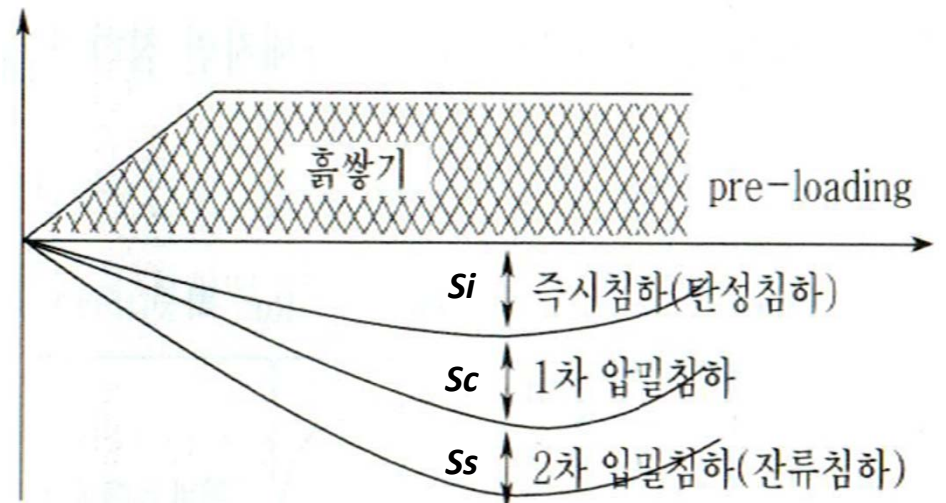

Field Survey and Testing

- Settlement Calculation

- 사질토
$$S = \sum 0.4 \frac{P_1}{N} H \log \frac{P_1 + \Delta P}{P_1}$$

- 점성토
$$S = \sum \frac{C_c}{1 + e_0} H \log \frac{P_1 + \Delta P}{P_1}$$

여기서, S : 압밀침하량

C_c : 압축지수

e_0 : 초기 간극비

H : 층의 두께(cm)

P_1 : 유효상재하중(kg/cm²)

ΔP : 하중에 의한 연직응력의 증가분(kg/cm²)

N : 표준관입시험치

- Calculate settlement of the clay soil when the field void ratio = 1.4, LL = 60%, the soil depth = 3m and the effective loading changes from 10t/m² to 15.2t/m².

Field Survey and Testing

- 그렇다면 침하 기초를 어떻게 보강할 것인가
- Jack Pile
 - 지반을 천공하거나 해머로 타격하지 않고 가압장치와 유압잭으로 말뚝을 진동, 소음/분진 없이 계측 압입
 - 기존 구조물의 기초 하부지반 교란 방지
 - 압입 시 유압게이지에 표시된 압력으로 말뚝 선단의 지층상태를 압입과정에서 자동적으로 확인

Field Survey and Testing

(1) E등급 부등침하 건축물 A 등급 복원인상

1969년 준공 이후 침하 지속 증가 E등급 ⇒ A등급

복원



그림 1.11.1 걸스카우트연맹빌딩 침하복원, 2009

(2) 기존 구조물 수직 乘上(乘高)



그림 1.11.2 (a)호박돌기초 문화재 1.3m 승상, 2008

(3) 기존 구조물 기초보강

B3~10층 사용 중 16층 증축을 위한 압입파일 기초 보강

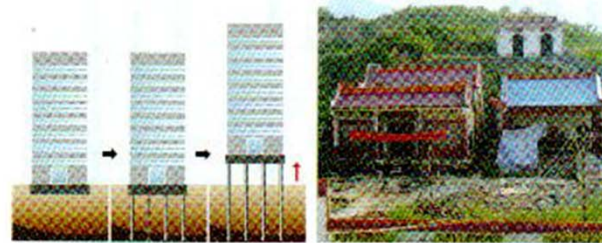

그림 1.11.3 증축 기초보강, 2009

(4) 기존 구조물 지하증축

압입파일 보강 뜬구조 형성 지하4층 하부 굴착

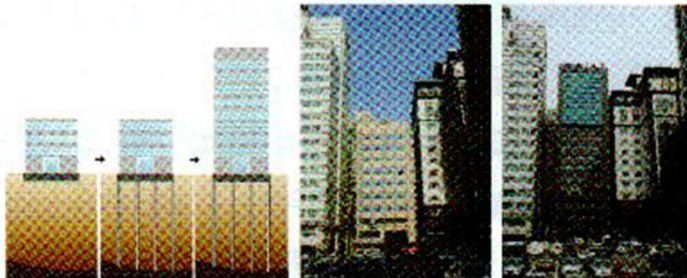

그림 1.11.4 지하증축, 2010

(5) Top·Down 동시시공

도심지 소음, 진동 대책으로 골조타설 후 기초보강



그림 1.11.5 Top Down 동시시공, 2010

(6) 인상 교체·치환

슬래브 인상 침하 균열발생 18m PC보 철거 교체시공

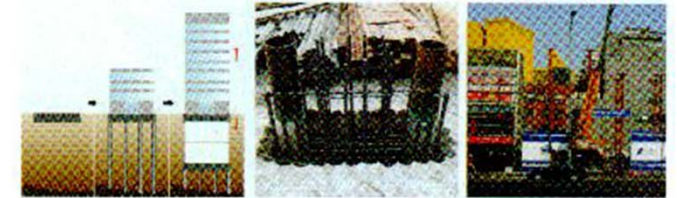

그림 1.11.6 교체

Field Survey and Testing

- Boring (천공)

- 지반구성 및 지하수위파악, 불교란 시료채취 및 표준관입시험(S.P.T) 실시 등을 위하여 지반에 구멍을 뚫는 작업
- 외관조사를 제외한 모든 지반조사에 반드시 시행되는 작업
- Auger boring: 천공하는데 시끄러운 소리가 나지 않으며 천공방법에 따라 자주식과 인력식이 있음, 교란시료채취, 도로공사 등 5-10m 이내의 천공에 적합
- Rotary boring: 보링 파이프 자체의 회전식, 균열상황의 관찰, 불교란 시료채취, 암석코어채취, N값 측정 등에 사용
- Percussion boring: 공기압력을 이용한 피스톤 충격으로 천공, 우물 및 자원 조사, 코어채취 불가능, 작고 깨끗한 천공



Field Survey and Testing

- **Boring: In site sampling**

- Disturbed sample (교란, 흐트러진 시료): 코어채취과정에서 교란된 시료로 입도분석, 액성한계시험, 소성한계시험, 흙비중시험 등 흙의 조직에 관계가 없는 물리적 특성을 파악하는데 사용됨.
- Undisturbed sample (불교란시료): 절대적으로 불교란시료란 얻기가 불가능하겠으나 가능한 자연상태의 시료를 얻어 압밀시험, 전단강도시험 등과 같은 흙의 조직에 의해서 지배되는 자연상태의 역학적 특성을 파악하는데 활용됨.

Field Survey and Testing

- **Standard Penetration Test (SPT, 표준관입시험)**

- N값: 63.5kg.f(force)의 해머로 76cm 높이에서 낙하시켜 표준관입 시험용 샘플러를 30cm 관입시킬 때의 타격횟수
 - $N > 30$: 말뚝지지층이 가능함
 - $N < 10$: 푸팅기초가 곤란함

N	Condition	1축 압축강도
< 2	대단히 연약	< 0.25 q_u (kg/cm ²)
2 - 4	연약	0.25 - 0.5
4 - 8	중간	0.5 - 1.0
8 - 15	견고	1.0 - 2.0
15 - 30	대단히 견고	2.0 - 4.0
> 30	고결	> 4.0

- 로드길이에 대한 수정 및 토질에 의한 수정이 필요

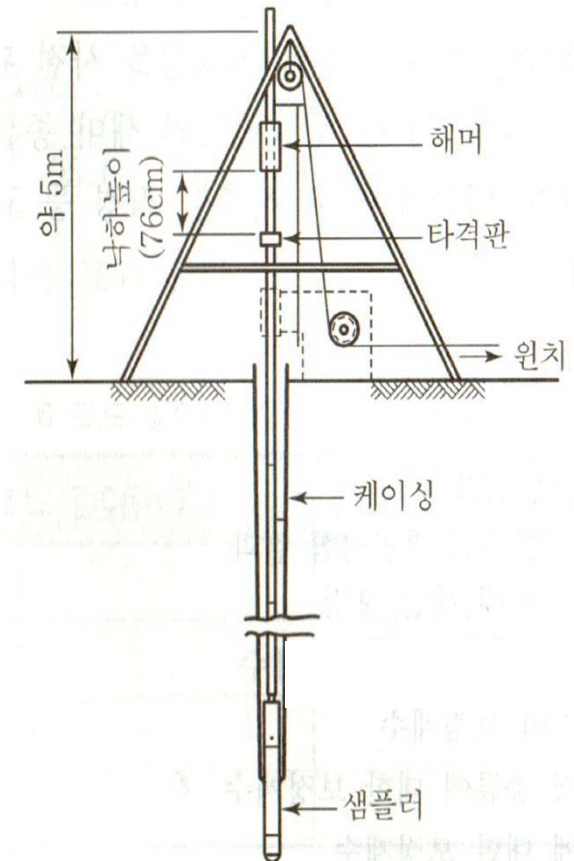

Field Survey and Testing

- Boring 심도

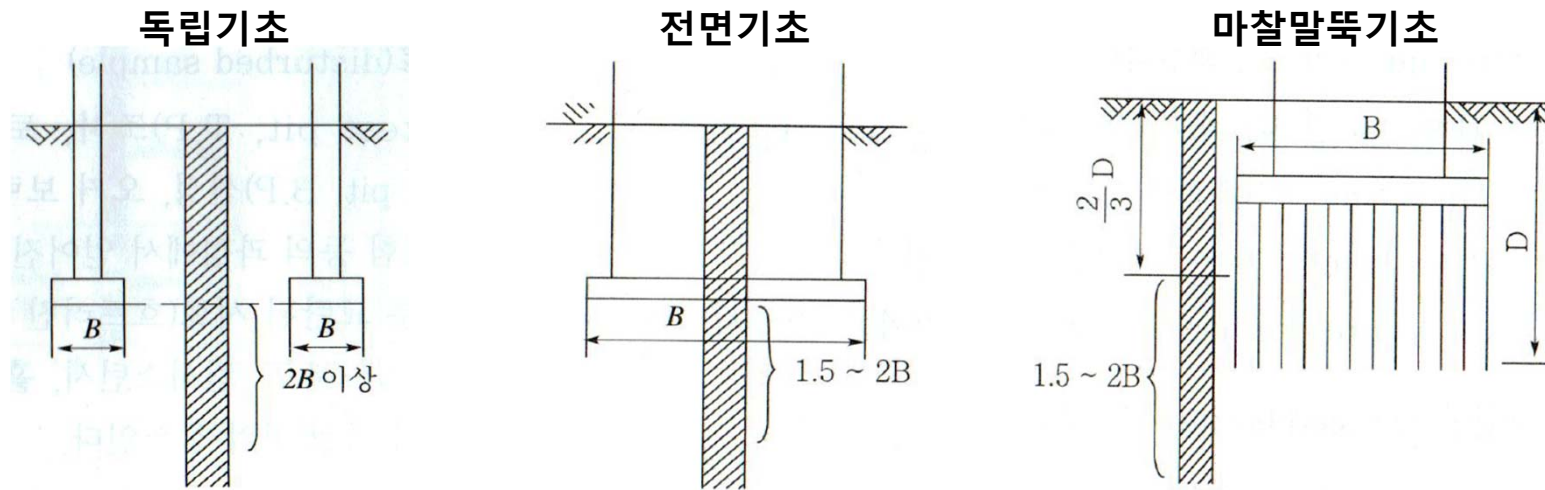

구조물	보통지층 분포지역	연약층
고층구조물	기초 계획면 또는 깊은 기초의 하단에서 하부 1.5B까지 전면기초의 경우는 암반층(연암층 이상) 3m 까지 확인	지지층 하부 1.5B까지
교대, 교각	기초 계획면 또는 깊은 기초의 하단에서 하부 2B까지	2B까지
도로	절토부: 포장노상면에서 2m 깊이까지 성토부: 지반면에서 성토높이 정도 또는 암반 2m까지	3m까지
터널	터널 바닥부의 계획심도에서 1D (최대터널지경)의 깊이까지	좌동
하천제방	제방높이와 같은 심도까지	3m까지

Field Survey and Testing

• 보링주상도

조사명 PROJECT		대전지하철 1호선 1단계 2구간 지반조사			시추번호 HOLE NO.		BH-9 (1 of 1)		
위치 LOCATION		STA. 2K267, 우4m	좌표 COORDINATES		X: 313,096.187 Y: 240,555.986	표고 ELEVATION		161.82M	
시추각도 ANGLE		VERTICAL	시추구경 HOLE DIA.		NX		지하수위 G. W. L.		2.0 M
사용장비 DRILL		OP-1000	시추자 DRILLER		M. J. LEE		조사자 INSPECTOR		K. J. KIM
깊이 DEPTH m	시추구경 HOLE DIA. mm	시추방법 METHOD	지층실명 (DESCRIPTION OF MATERIAL)	시추속도 COR. REC. %	시추도구 COR. ROD	시추도구 COR. ROD	투수계수 (PERMEABILITY)		
							BLOWS /30cm	표준관입시험 (S. P. T)	
4.80 (157.02)	4.80	NX	Medium dense, moist, dark brown to dark brown, silty fine to coarse SAND with gravel : FILL (매립토)						
7.20 (149.82)	7.20	OP	Gray to dark gray, highly to moderately fractured, highly to moderately weathered, weak to moderately strong : GRANITE (연암) 부분적으로 절리면에 점토물이 협재하여 shear sense를 보임	100/47	C1				
12.00 (147.82)	12.00			100/10	C2				
14.00 (147.82)	14.00		Gray to dark gray, moderately to slightly fractured, moderately to slightly weathered, moderately strong to strong : GRANITE (경암) 13.9m : slicken sided	100/80	C4				
			시추종료 (End of Boring)						

NX: 77.79mm(내경), 88.90mm(외경), 토사 및 암반용 시료채취 시험공구

RQD(Rock Quality Designation): 10cm 이상 코어 길이 총합 / 이론적 굴진 깊이

TCR(Total Core Recovery): 회수된 코어 길이의 총합 / 이론적 굴진 깊이

범례 LEGEND

- | | | | | | |
|---|---------------------------|---|------------------------------|---|---------------------------|
| D | 교란 시료
DISTURBED SAMPLE | U | 불교란 시료
UNDISTURBED SAMPLE | C | 암석코어
CORE SAMPLE |
| L | 시료 없음
LOST SAMPLE | d | 대니슨 샘플러
DENISON SAMPLER | p | 피스톤 샘플러
PISTON SAMPLER |

Field Survey and Testing

- Plate Bearing Test (PBT, 평판재하시험)

- 어느 지반에 실제 구조물을 축조하였을 때 지지력이나 침하조건이 만족되는지 여부를 판단하는 시험
- 현장에서 재하장비로는 지지대를 설치하는 경우도 있고 이동성을 고려하여 덤프트럭, 페이로더 등이 이용됨
- K (지지력 계수, kg/cm^3) = q (하중강도, kg/cm^2) / y (침하량)

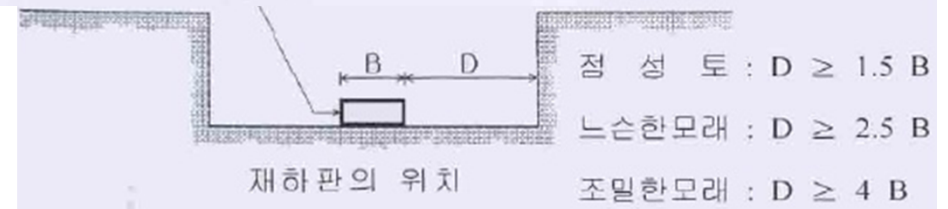
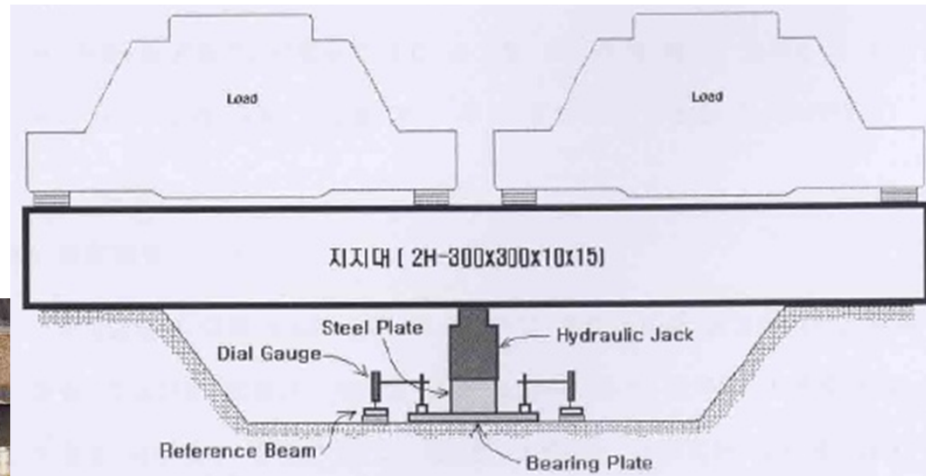
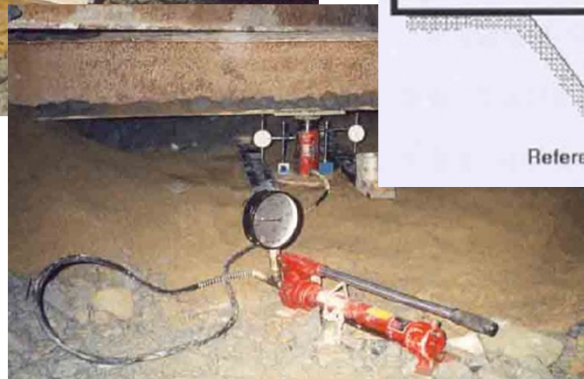

Foundation Methods

- **Foundation:** Part of a structural system that supports and anchors the superstructure and transmits its loads to the earth

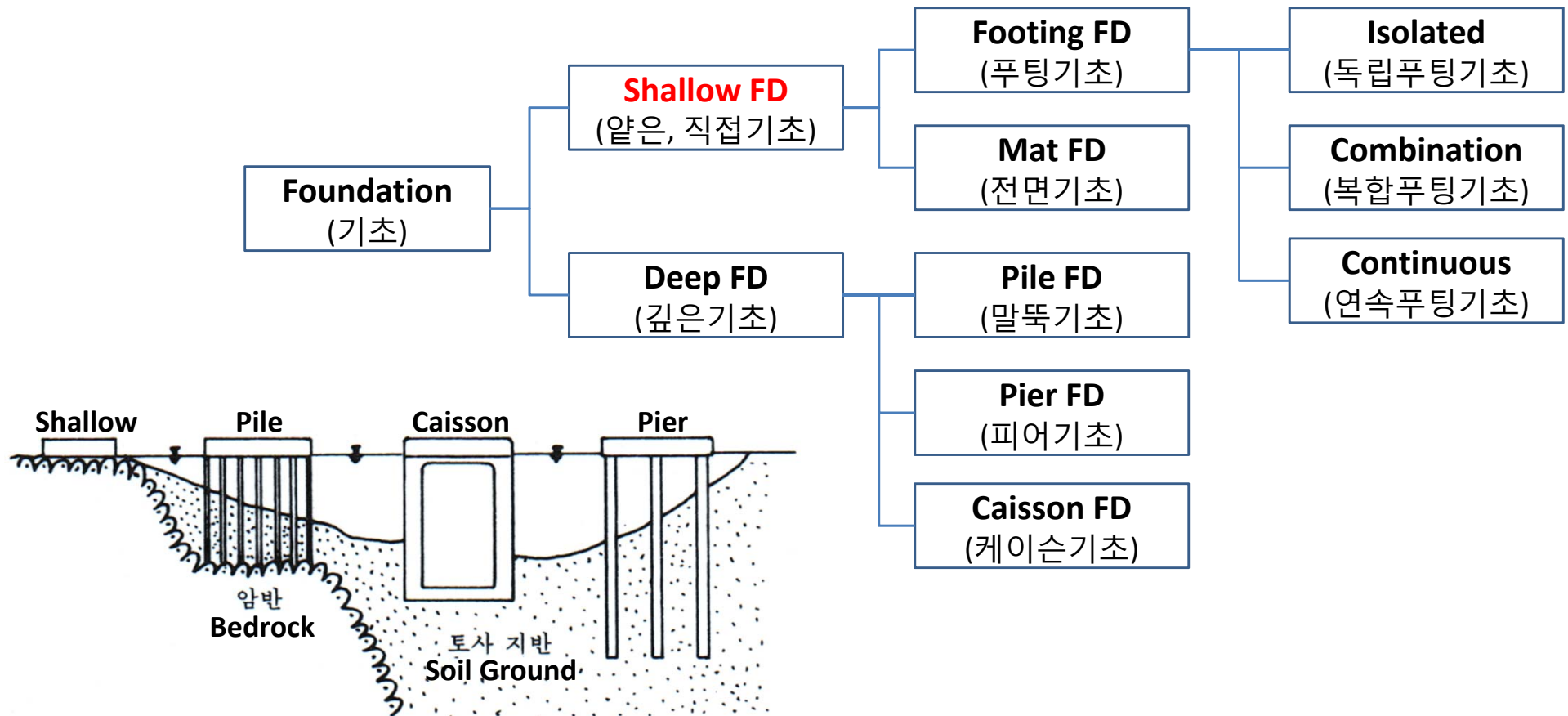

Foundation Methods

- **Generalized foundation design steps**
 - Calculate loads from structure, surcharge, active and passive pressure, etc.
 - Characterize soil: Hire a firm to conduct soil tests and produce a report that includes soil material properties
 - Determine footing location and depth: Shallow footings are less expensive, but the variability of the soil from the geotechnical report will drive choices
 - Determine footing size: These calculations are based on working loads and the allowable soil pressure
 - Evaluate soil bearing capacity: The factor of safety is considered here
 - Calculate contact pressure and check stability
 - Estimate settlements
 - Design the footing structure

Foundation Methods

- **Shallow Foundation**

- Soil ground has suitable bearing capacity for direct slab foundation
- Easier to be built than deep foundation

- **Type**

- **Spread footing**: a single column bears on a square, rectangular, or circular pad to distribute the load over a bigger area, simple to build and economical, soil should satisfy required bearing capacity
- **Continuous footing**: a continuous wall bears on a wide pad to distribute the loads
- **Combined footing**: multiple columns (typically two) bear on a rectangular or trapezoidal shaped footing

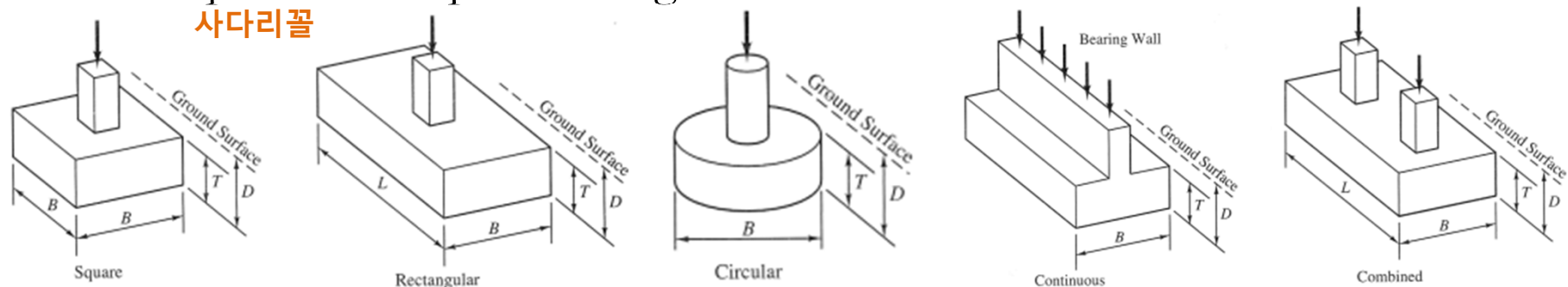

Foundation Methods

- Type

- **Mat foundation:** a slab that supports multiple columns. The mat can be stiffened with a grid or grade beams.

- 기초면적이 시공면적의 2/3이상 되는 기초, 지반조건이 좋지 않고 부등침하가 발생하기 쉬운 지형, 구조물의 하부가 지하수위 아래에 위치하고 있어 차수나 방수가 중요시될 경우, 도심지 건축 및 지하철 구조물



Combined Footing

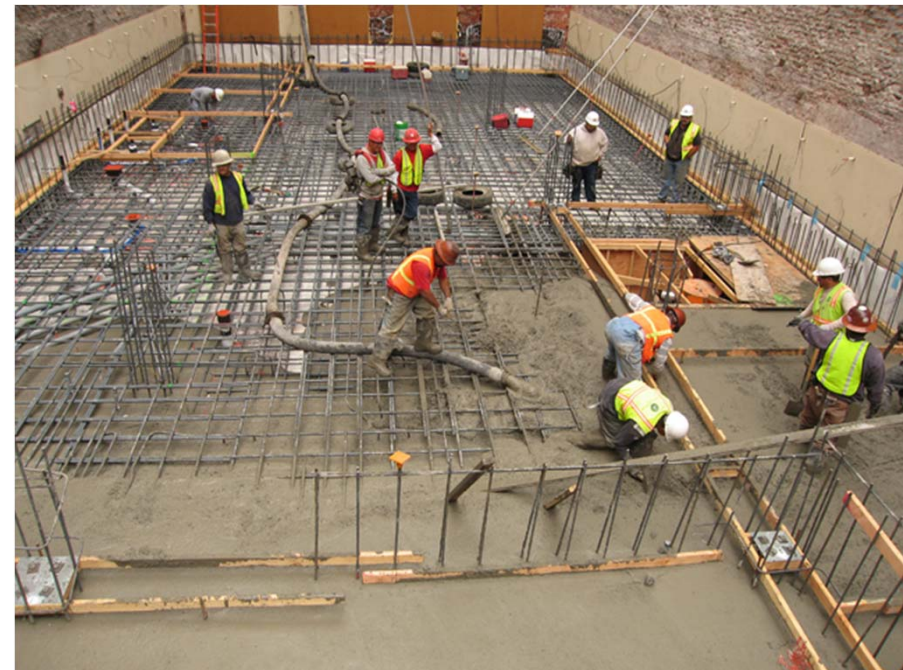

Mat Foundation

* $q_u - q$: ultimate bearing capacity of soil only under the foundation structure

$$q = D_f \times r$$

Foundation Methods

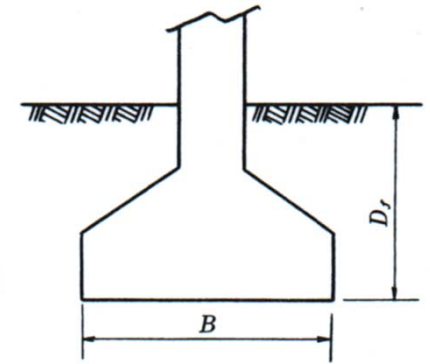

- 얕은기초의 지지력 (Terzaghi theory)

- Foundation bed width $B >$ Foundation depth D_f
- Ultimate bearing capacity of normal soil (극한지지력, q_u)

$$q_u = \alpha C N_c + \beta r_1 B N_r + r_2 D_f N_q$$

α, β : 기초의 형상계수

N_c, N_r, N_q : 지지력계수

C : 흙의 점착력

B : 기초의 폭

A : 기초 면적

D_f : 기초의 근입깊이

γ_1 : 기초하중면 아래에 있는 지반의 단위 중량

γ_2 : 기초하중면 위쪽에 있는 지반의 단위 중량

	Conti.	Square	Circle	Rectangle
α	1.0	1.3	1.3	$1 + 0.3B/L$
β	0.5	0.4	0.3	$0.5 - 0.1B/L$

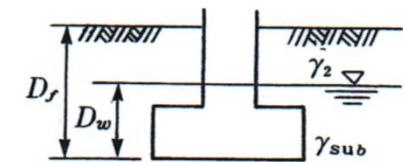

(a)

(a) $r'_2 = r_2 - \frac{D_w}{D_f} (r_2 - r_{sub})$ (insert r'_2 instead of r_2)

(b) $r_1 = r_{sub} + \frac{D_w}{B} (r_2 - r_{sub})$ * $r_{sub} = r_{sat} - r_w(1.0t/m^3)$

Allowable Bearing Capacity (허용지지력): $q_a = q_u / F_s$ (Safety Factor)

Net Allowable Bearing Capacity (순허용지지력): $q_{all} = (q_u - q) / F_s$
 * $q = D_f \cdot r_2$

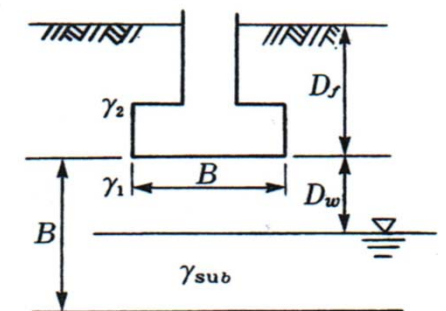

(b)

Foundation Methods

- 지하수위보다 기초의 위치가 더 낮게 되면 저면에 양압력이 작용하게 되고 이 양압력보다 저면에 작용하는 상부하중이 적으면 구조물이 부상
 - 양압력: 수위차 및 수면하 수평 유속때문에 양압력이 발생하기 때문에 부력에 추가해서 수평유속이 빠르면 구조물이 더 떠오르는 효과가 발생
 - 지하수위 심도, 구조물에 작용하는 양압력의 폭, 물의 단위중량 등을 고려
 - 물의 무게 자체를 모두 고려한 것이며 r_{sub} (수중단위중량) = $r_{sat} - r_w$
- 지하주차장 등 바닥면적 크기가 거대화 됨에 따라 저면에 접하게 되는 바닥층 공사에서 발생할 수 있는 부력 방지대책이 매우 중요
 - 문제점: 구조물 균형 상실, 부재 균열, 누수 및 파손 등
 - 지반조사 주상도 및 지하수위를 파악하여 시공단계 및 완성 구조물의 부력 사전 검토
 - 호우 시 지표수의 유입에 의해 급격히 지하수가 상승하지 않도록 대책 강구
 - 지표수 배수 강화, 굴착구 내로 지하수 유입 방지, 부력방지 Anchor설치, 경우에 따라 지하수 상승 시 구조물 내로 지하수가 유입하도록 조치 등

Foundation Methods

- For continuous foundation construction, calculate (1) ultimate bearing capacity and (2) allowable bearing capacity. ($c = 1.6\text{t/m}^2$, $r = 1.8\text{t/m}^3$, $r_{\text{sat}} = 2.0\text{t/m}^3$, $F_s = 3$, $N_c = 17.7$, $N_r = 5$, $N_q = 7.4$)

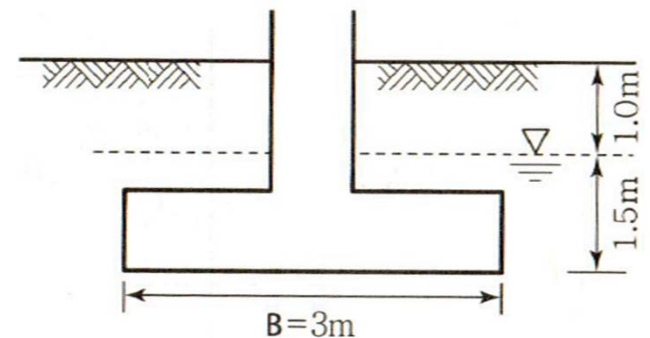

Foundation Methods

- For square shape foundation construction, calculate (1) ultimate bearing capacity and (2) allowable bearing capacity, and (3) net allowable bearing capacity. ($F_s = 3$, $N_c = 17.7$, $N_r = 5$, $N_q = 7.4$)

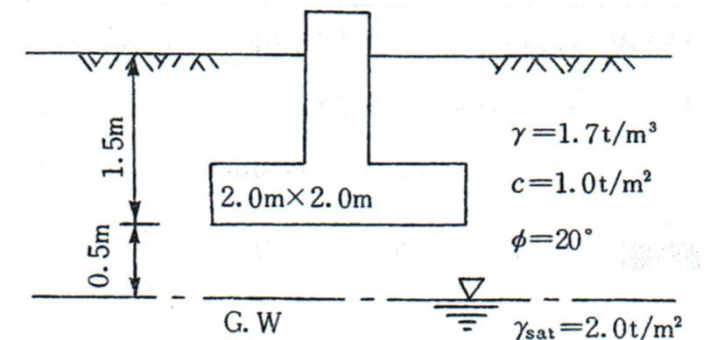

Foundation Methods

- **Shallow Foundation: Cutting Methods**

- **Open cut:** for wide ground having good soil conditions
- **Island method:** excavate the center of foundation structure and build foundation like island. Support retaining walls by the built center and excavate remaining soils
- **Trench method:** opposite to the island method. Excavate and built foundation edges first, use it as a retaining wall and move to the center position

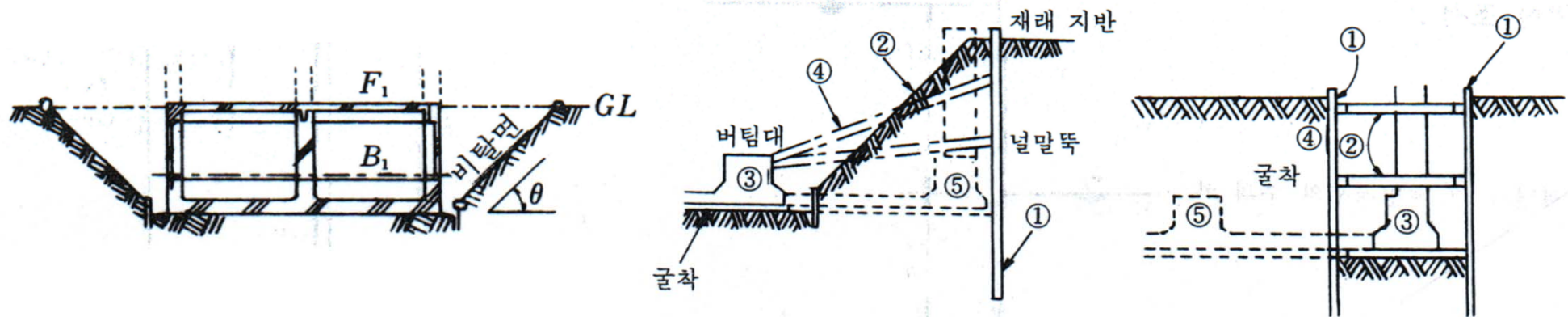

Foundation Methods

- Heaving

- 연약한 점토질 지반을 굴착할 때 토류공 배면의 흙의 중량이 굴착면 이하 지반의 극한 지지력보다 크게 되어 배면 토사가 토류공의 내측을 향해서 유동하기 시작하여 이것 때문에 굴착 저면이 팽창하는 현상
- Safety to heaving

- Driving moment of heaving (M_d)

$$\begin{aligned} M_d &= W \times 0.5R + qR \times 0.5R \\ &= r_1 H \cdot R \times 0.5R + 0.5qR^2 \\ &= 0.5R^2(r_1 H + q) \end{aligned}$$

- Resistance moment to heaving (M_r)

$$\begin{aligned} M_r &= \pi R C_2 \times R + H C_1 \times R \\ &= \pi C_2 R^2 + H C_1 R \end{aligned}$$

- Safety factor (F_s) = M_r / M_d

- Need to $F_s > 1.2$ to be safe

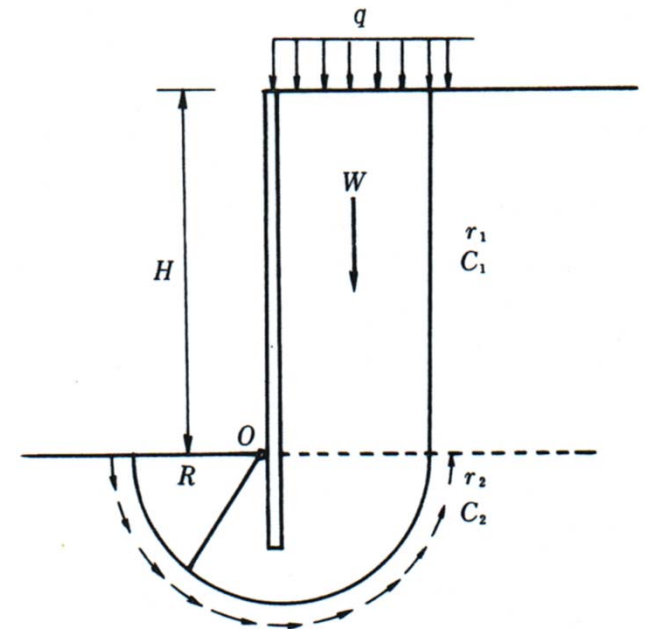

Foundation Methods

- Estimate safety to heaving

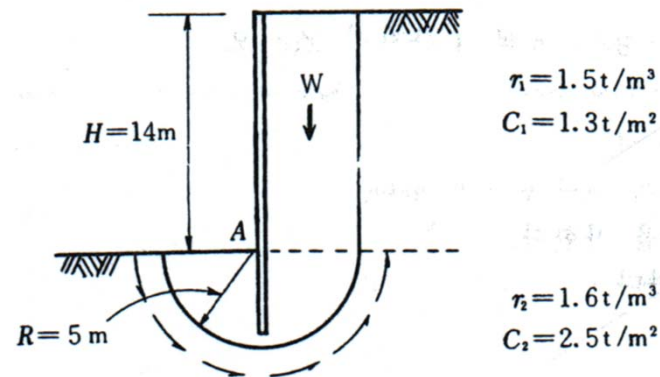

Foundation Methods

- **How to prevent heaving**

- Set up the retaining wall deeper
- Change cutting methods (e.g., open cut to the island method)
- Increase stability of foundation ground by cement grouting (injection), chemical injection, underground water drainage, compression, etc.
- Technically increase stability of the retaining wall (e.g., bracing, anchoring)

- **Boiling**

- 모래지반에서 지하수위 이하를 굴착할 때 토류벽의 기초 깊이에 비해서 배면의 수위가 너무 높으면 굴착 저면의 모래 입자가 지하수와 더불어 분출하여 굴착 저면이 마치 물이 끓는 상태와 같이 되는 현상

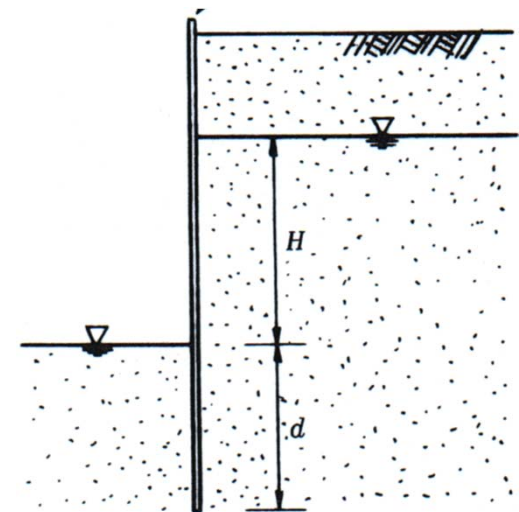

Deep Foundation

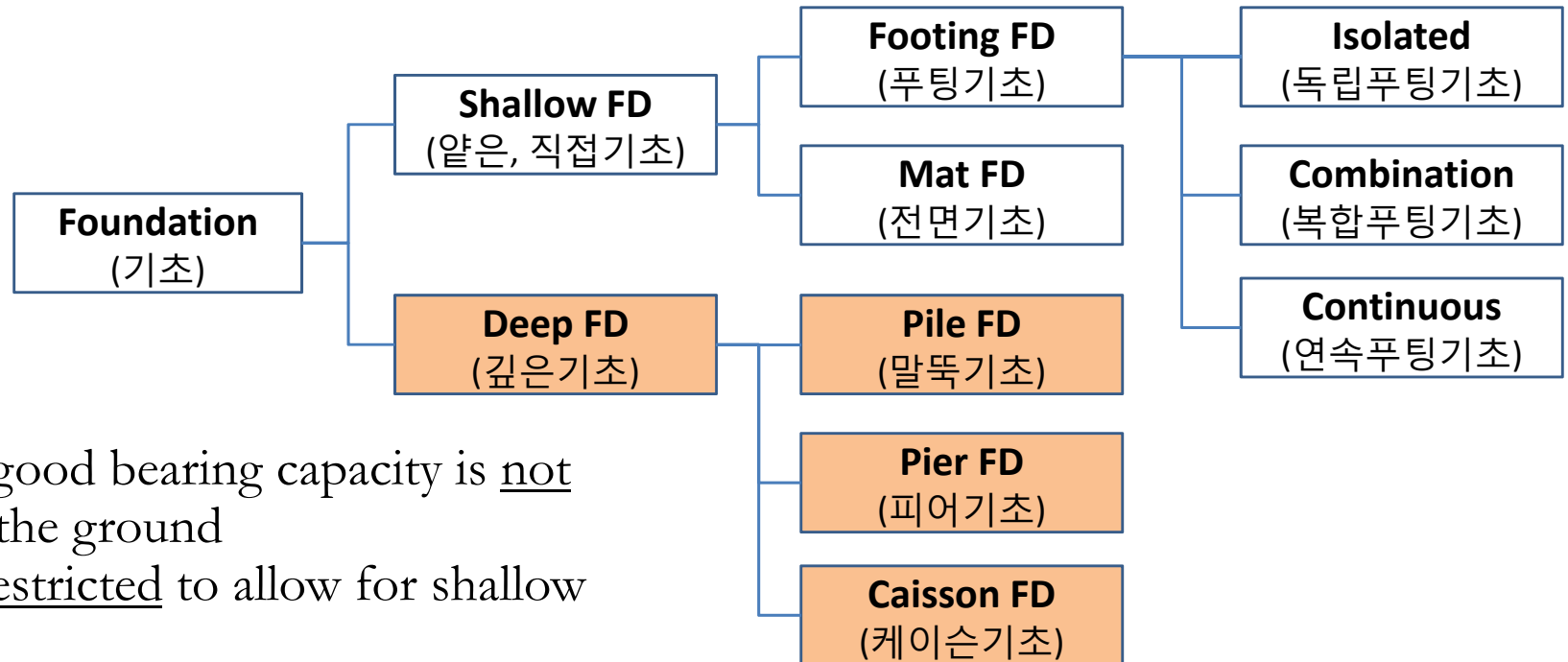

- The strata of good bearing capacity is not available near the ground
- The space is restricted to allow for shallow foundation
- The foundation structure has to be taken deep with the purpose of attaining a bearing stratum which is suitable and which ensures stability and durability of the superstructure
- The depth of the foundation is very large in comparison to its width
- Not constructed by ordinary methods of open pit excavations

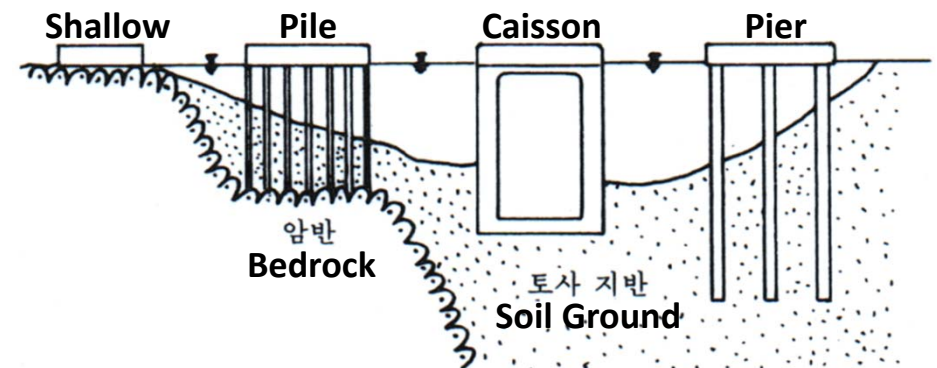

Pile Foundation

- Column driven into the soil to support a structure by transferring loads to a deeper and stronger layer of soil or rock
- Provide a common solution to all difficult foundation site problems
- Can be used for any type of structure and in any type of soil
- **Situation for pile foundation**
 - Heavy and non-uniform loading from the structure
 - For saving time and money
 - Soil is compressible and firm hard bearing strata is located at a large depth
 - Structures are located on river-bed or sea-shore having high likelihood to be scoured due to action of water
 - Large fluctuations in sub-soil water level, Canal or deep drainage lines exist near the foundations

Pile Foundation

- **Classification based on bearing capacity (지지력에 의한 분류)**
 - **End bearing pile**(선단지지말뚝): driven into the ground until a hard stratum is reached. Piles do not support the load rather acts as a medium to transmit the load from the foundation to the resisting sub-stratum
 - **Friction pile**(마찰말뚝): driven at a site where soil is not economical or rather possible to rest the bottom end of the pile on the hard stratum, Load is carried by the friction developed between the sides of the pile and the surrounding ground
(to determine a depth → skin friction = load coming on the pile)
 - **Bearing or supporting pile**(하부지반에 의한 지지말뚝): driven into the ground until a hard stratum and passes it to get further friction

Pile Foundation

- How to increase the load carrying capacity of friction pile
 - Increase diameter of the pile
 - Drive the pile for larger depth
 - Group several piles
 - Make surface of the pile rough

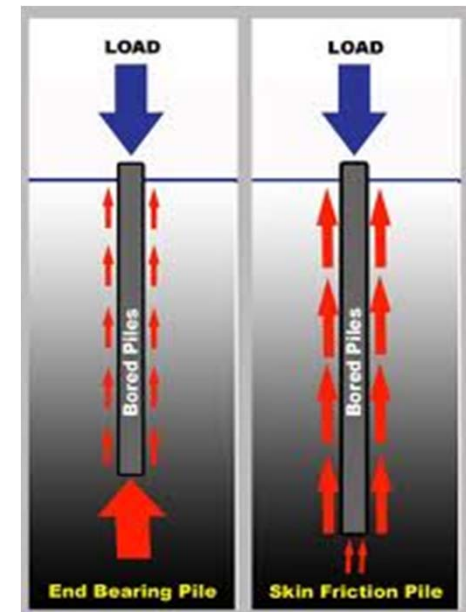
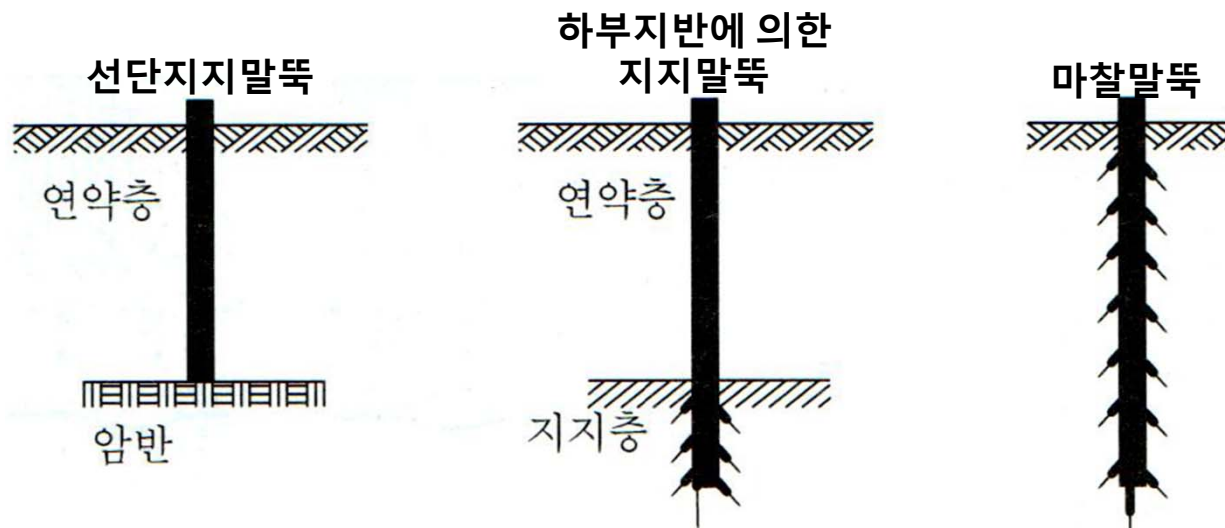

Pile Foundation

- Classification based on **usage purposes (사용목적에 의한 분류)**
 - **Compaction pile**(다짐말뚝): to improve compaction while piling, good to be used for loose sandy soils
 - **Stabilizing pile**(억류말뚝): to stabilize and protect slopes
 - **Batter pile**(사항, 경사말뚝): to compensate horizontal weakness of piles and resist large horizontal and inclined forces
 - **Lateral resistance pile**(수평저항말뚝): batter piles, retaining piles, fender piles (protect dock walls, decks), etc. that provide horizontal supports

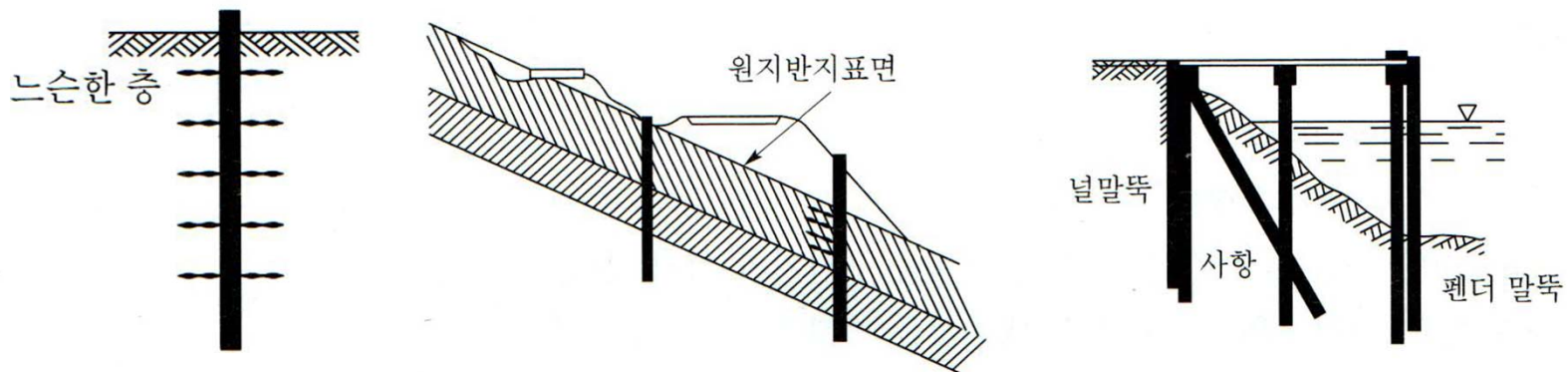

응력분포를 알아야 지반이 그러한 응력에 저항할 수 있는지를 확인할 수 있고 이에 맞도록 파일 설계

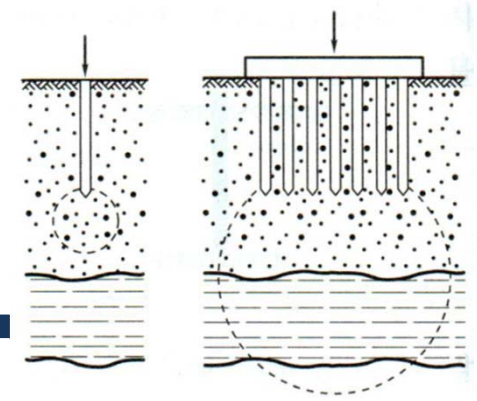

Pile Foundation

- **Classification based on functions (기능에 의한 분류)**

- **Single pile**(단항): underground stresses of two or more piles are independent, piles are located far

$$D_o > 1.5\sqrt{r \cdot L}$$

(D_o : distance between piles, r : pile radius, L : pile penetration depth)

- **Group pile**(군항): underground stresses(지중응력) of two or more piles affect each other, piles are closely located, reduce bearing capacity of piles

$$D_o \leq 1.5\sqrt{r \cdot L}$$

- When piling into clay soils or clay soils exist under the pile end, should consider effects of group piles on bearing capacity reduction and possible settlement
- Normally 70-80% of single pile's bearing capacity (응력분포가 커져서 bearing capacity는 작아짐)

Pile Foundation

- Classification based on functions

- Efficiency of bearing capacity (Group piles, 군항의 지지력 효율)

$$E = 1 - \frac{\psi}{90} \left\{ \frac{(n-1)m + (m-1)n}{mn} \right\}$$

$$\psi = \tan^{-1} \frac{D}{S}$$

n: number of rows of group piles

m: number of piles in one row

D: diameter of a pile

S: distance between pile centers

*(*if different, take smaller S for calculation)*

- Allowable bearing capacity of group piles (군항의 허용지지력)

$$R_{ag} = E \cdot N \cdot R_a$$

N: number of piles, R_a: allowable bearing capacity as a single pile

Pile Foundation

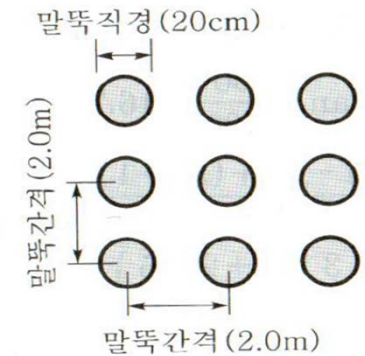

- **Group piles**

- Is following pile foundation a single pile or group piles? ($L = 15\text{m}$)

- There is group piles consisting 20 piles. If the allowable bearing capacity as a single pile is 20t, calculate the allowable bearing capacity of the foundation.

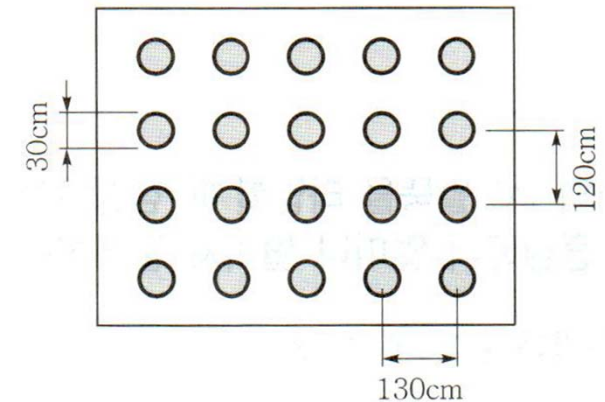

Pile Foundation

- **Classification based on materials (재료에 의한 분류)**
 - Timber piles
 - Untreated (last only couple of years – only temporarily used)
 - Treated with a preservative (salt or creosote)
 - Concrete piles
 - Precast concrete piles
 - Cast-in-place concrete piles
 - Steel piles
 - Steel H sections
 - Steel pipe piles
 - Composite piles
 - Concrete and steel
 - Plastic with steel pipe core

Pile Foundation



- Timber piles

Advantages:

- More popular lengths and sizes are available on **short notice**
- **Economical** in cost
- They are **handled easily** (light) with little danger of breakage
- After driving, they can be **easily cut** to any desired length
- Can be **extracted easily** in the event removal is necessary

****In these days, less used except for temporary construction***

Disadvantages

- May be **difficult to obtain piles sufficiently long and straight**
- Can be **difficult or impossible to use in hard formations**
- **Difficult to splice** when increased lengths are necessary **붙이다**
- Usually **not suitable to use as end-bearing piles** under heavy loads: better for friction bearing piles
- Usually **require treatment with preservatives** to maintain structural capacity over required duration: possible environmental impact.

**kip: 1,000 pound force
psi: pounds per square inch*

Pile Foundation

- **Concrete piles: Precast concrete piles**
 - For projects with a large quantity of piles, transportation costs from existing manufacturing plants may be significant. Thus, it may be cost-effective to set up a casting facility on the job or in the general vicinity of the project. The establishment of such a facility requires a substantial investment in specific equipment and casting forms as well as a sufficient amount of space for the casting beds, curing area and storage yard.

- (1) Prestressing strand will be as long as the casting bed*
- (2) Bulkheads will be placed in the forms as determined by the desired pile lengths*
- (3) Utilizing stressing jacks, each strand will be pretensioned to between 20 and 35 kips prior to the concrete placement*
- (4) Immediately following the concrete placement, the piles are covered with curing blankets and steam is introduced*
- (5) The curing continues and the prestressing forces are released when the concrete has attained a minimum compressive strength of 3,500 psi*

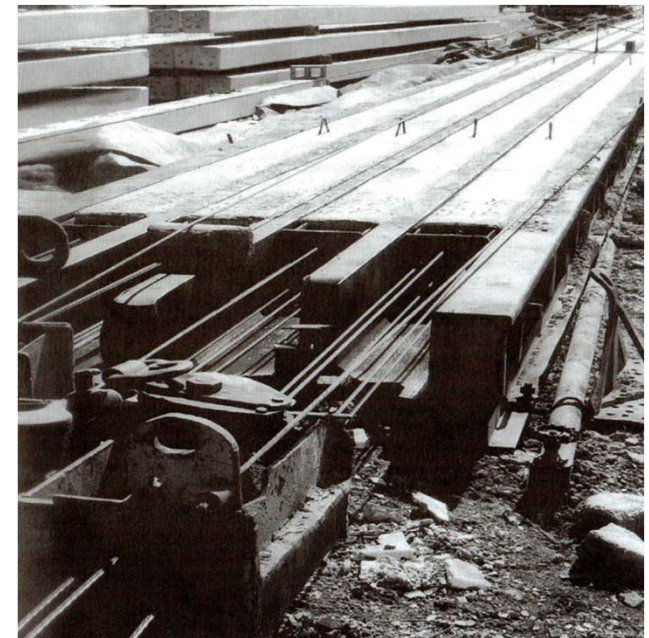

Pile Foundation

- **Concrete piles: Precast concrete piles**

Advantages:

- **High resistance** to chemical and biological attacks
- **High load-carrying capacity**
- Simple quality control
- In the case of hollow cylinder piles, a water pipe can be installed along the center of the pile to facilitate jetting

Disadvantages

- **Difficult to reduce or increase the length:** necessary for good site investigation during planning
- Large sizes **require heavy and expensive handling and driving** equipment
- The **inability to quickly obtain piles** by purchase may delay the starting of a project
- **Possible breakage** of piles during handling or driving produces a delay hazard

Pile Foundation

- **Concrete piles: Cast-in-place concrete piles**
 - Cast in position inside the ground
 - Driving a metallic shell and leaving it in the ground and then filling the shell with concrete (cased) OR Driving a metallic shell and filling the resulting void with concrete as the shell is pulled from the ground (uncased)

Raymond step-taper concrete pile: installed by driving a spirally corrugated(주름진) steel shell. After a shell is assembled to the desired length, a step-tapered (점점 가늘어지는) rigid-steel core is inserted and the shell is driven to the desired penetration. The core is removed and the shell is filled with concrete.

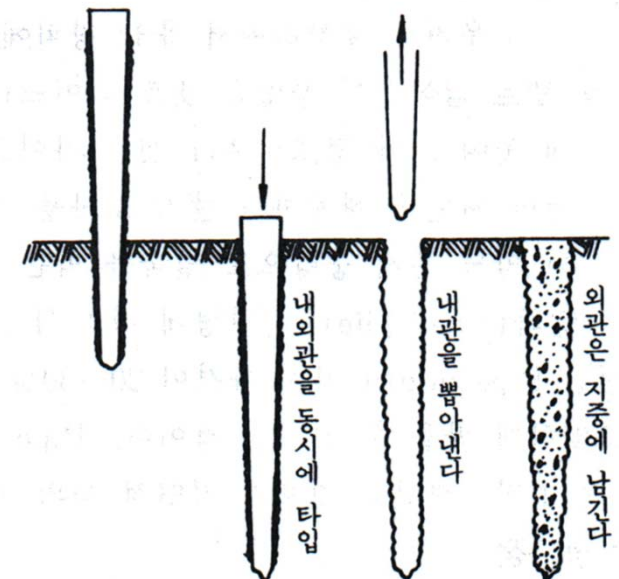

Pile Foundation

- **Concrete piles: Cast-in-place concrete piles**
 - **Augered cast-in-place pile**: do not require a shell or pipe.
 - (1) A hollow shaft auger is rotated into the soil to a predetermined tip elevation
 - (2) As the auger is withdrawn from the hole, grout is injected under pressure through the hollow shaft
 - (3) Concrete can be placed to the ground elevation and then cut off

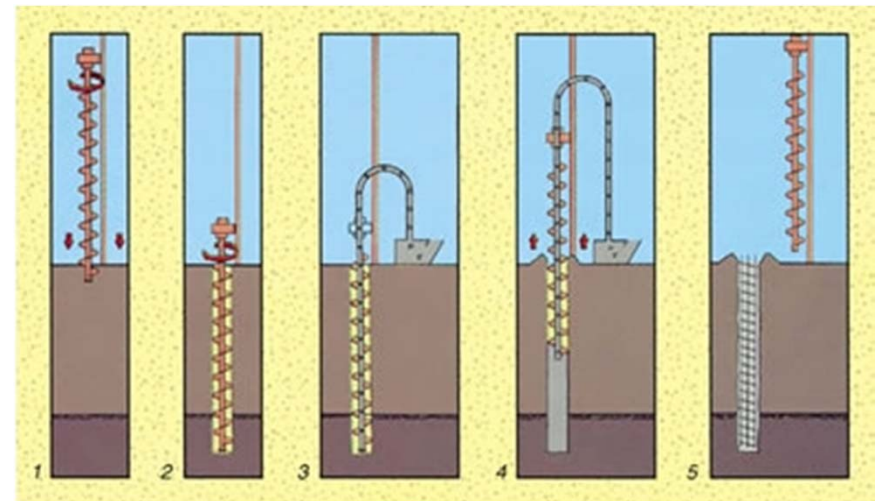

그라우팅:

지반의 지지력 증가, 투수성 감소, 지반과 구조물의 일체화 등을 목적으로 기초지반이나 구조물 주변 및 구조물 자체 내부로 각종 시멘트, 모르타르 등의 그라우트를 주입하는 것

Pile Foundation

- **Concrete piles: Cast-in-place concrete piles**
 - **Franki driven cast-in-situ pile**
 - (1) The drive tube is driven to the desired depth
 - (2) Concrete is dropped into the drive tube and compacted
 - (3) The drop hammer expels concrete from the tube
 - (4) Additional steps complete the footing

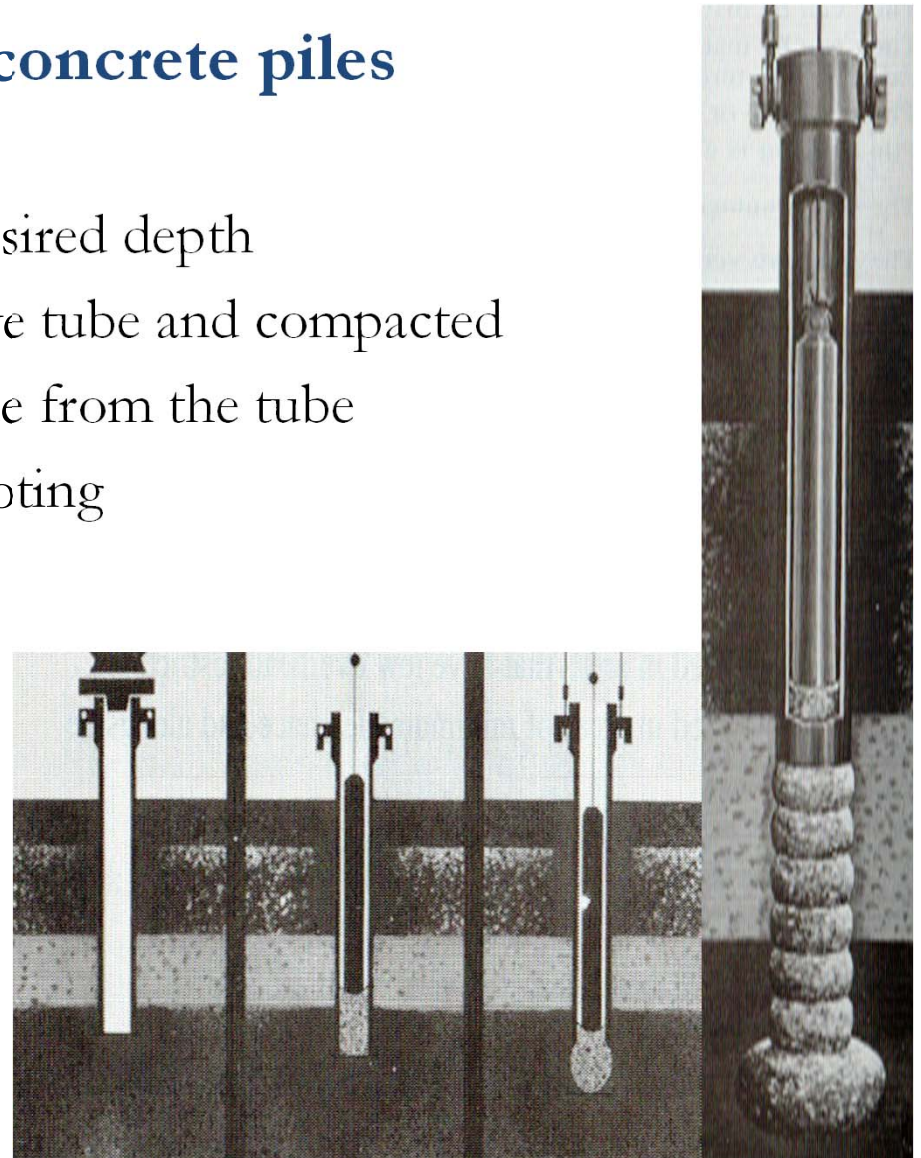

Pile Foundation

- **Concrete piles: Cast-in-place concrete piles**

Advantages:

- The **lightweight shells** can be handled and driven easily
- The length of a shell can be **increased or decreased easily**
- The shells can be **shipped in short lengths and assembled** at the job site
- The danger of **breaking** a pile while driving is **eliminated**
- **Additional piles** can be provided quickly if they are needed
- **No pile splicing**

Disadvantages

- A **slight movement of the earth** around an unreinforced pile may break it
- Require **careful placement of the concrete** to ensure a structurally sound shaft
- **Installation of reinforcing steel can be difficult**
- The bottom of a Franki pile may **not be symmetrical**

Pile Foundation



- **Steel piles**

- In constructing foundations that require piles driven to great depths with higher bearing capacity, steel piles probably are more suitable than any other type
- Easy to be welded: Because the steel piles can be driven in short lengths and additional lengths then welded on top of the previously driven section, they can be utilized more readily in situations where there are height restrictions that limit the length of piles that can be driven in one piece
- **Steel H section piles**: the great strength of steep combined with small displacement of soil permits a large portion of the energy from a pile hammer to be transmitted to the bottom of a pile, 20-30% cheaper than pipe piles
- **Steep-pipe piles**: better engineering performance than H section piles

Pile Foundation

- **Composite piles**

- Usually developed and offered to meet the demands of special situations

- Situations that cause problems are **hard ground** at the project site: cause problems with applying the energy necessary to drive the pile and at the same time being careful not to destroy the pile
- **Warm marine environments**: subject the pile to marine borer attacks and salt attacks on metal, therefore special piling protective measures are usually specified

**Marine borer: 해양천공생물*

- **Concrete and steel composite piles**

- When extremely hard soils or soil layers are encountered
- Top portion of the pile → prestressed concrete pile
- the tip → steel H pile embedded into the end of the concrete pile

Pile Foundation



- **Composite piles**

- Plastic with steel-pipe core piles

- Immune to marine borer attacks, eliminating the need for creosote treatments or special sheathings in marine environments
 - Their abrasive resistance makes them excellent for fender system use

- **Selection of pile types**

- Nature of ground
 - Nature of the structure and loading conditions
 - Elevation of the ground water level with respect to the pile cap
 - Probable length of pile required
 - Availability of materials and equipment
 - Factors which may cause deterioration of pile
 - Probable cost of pile

Pile Foundation

- **Pile Driving**

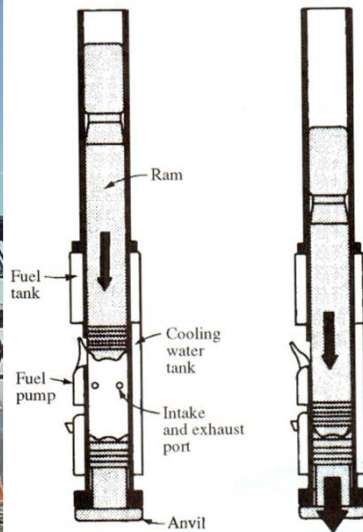

Diesel Hammer:
Self-contained driving unit within cylinder

Vibratory Hammer: Reduce friction b/w soils and a pile with vibration, for water-saturated/non-cohesive soils

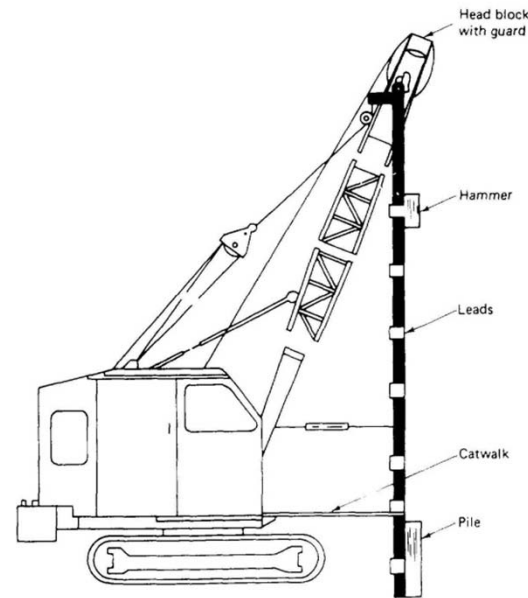

Drop Hammer:
Lifted by a hoist line



Stream/Air Hammer:
Ram lifted by steam or compressed air

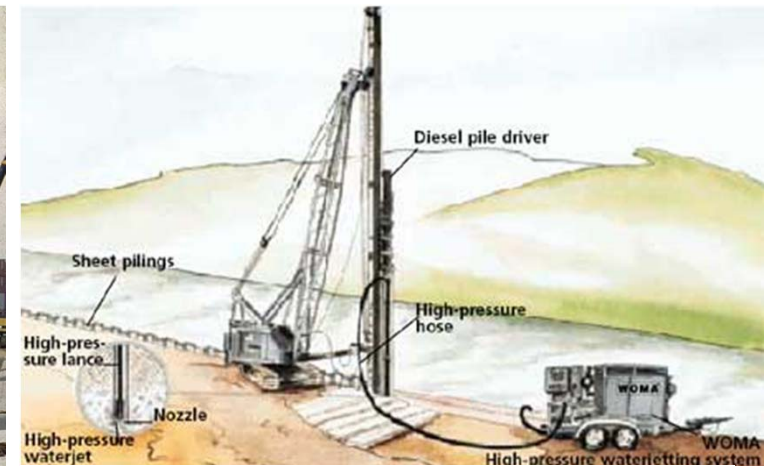

Water Jetting: Water jetting to assist in driving piles by reducing friction and loosening soils with high pressure

Pile Foundation

- **Pile-Supporting Strength**

- Many pile-driving, empirical equations
- *Engineering News* equation: most popular in the U.S.

- Drop hammer
$$R = \frac{2WH}{S + 1.0}$$

- Single-acting steam hammer
$$R = \frac{2WH}{S + 0.1}$$

- Double/Differential-acting steam hammer
$$R = \frac{2E}{S + 0.1}$$

R: safe load on a pile in pounds

W: weight of a falling mass in pounds

H: height of free fall for mass W in feet

E: total energy of ram at bottom of its downward stroke in foot-pounds

S: average penetration per blow for last 5 to 10 blows in inches

항타에 의한 동역학적 지지력 산정

Pile Foundation

- The falling ram of a drop hammer used to drive a timber pile is 5,000lb. The free-fall height during driving was 19 in., and the average penetration for the last eight blows was 0.5 in. per blow. What is the safe rated loading using the *Engineering News* equation?

Pier Foundation

- A reinforced concrete column ($D \geq 750\text{mm}$) constructed below the ground surface to transfer the load down to a stronger layer
- **Characteristics**
 - Good resistance to horizontal moment due to the large dimension
 - Can use one pier instead of group piles
 - Less noise and vibration: good for construction in urban areas
 - Machine excavation technique: applicable when piling is difficult
 - Less opportunity of heaving and soil vibration

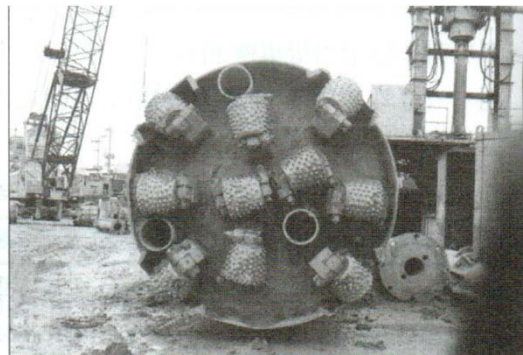

Tremie pipe: efficiently deliver fresh concrete to the bottom



Pier Foundation

- Risks during pier foundation

- Poor concrete quality: tremie pipe, quality control (타설 후 품질관리 곤란)
- Hollow wall collapse, Drilling difficulties: stabilizer liquid, good casing, appropriate drilling plans
- Rebar dislocation: installation of grid rebar(굵은 철근 또는 강재 버팀재) at the bottom, reinforce tying, slow down concrete placement speed
- Drilling plan changes



그림. 베노토공법의 시공순서



그림. 안정액을 사용한 Earth drill 공법

Caissons Foundation

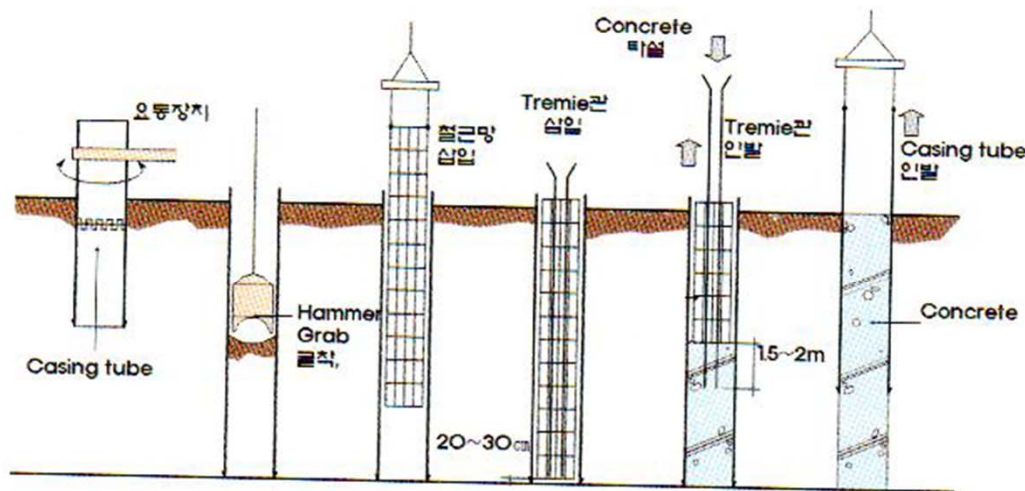
- Water light structures made up of wood, steel, or reinforced concrete constructed in connection with excavation for foundations of bridges, piers, abutments in river and lake dock structure for shore protection
- The caisson remains in its pose and ultimately becomes as integral parts of the permanent structure

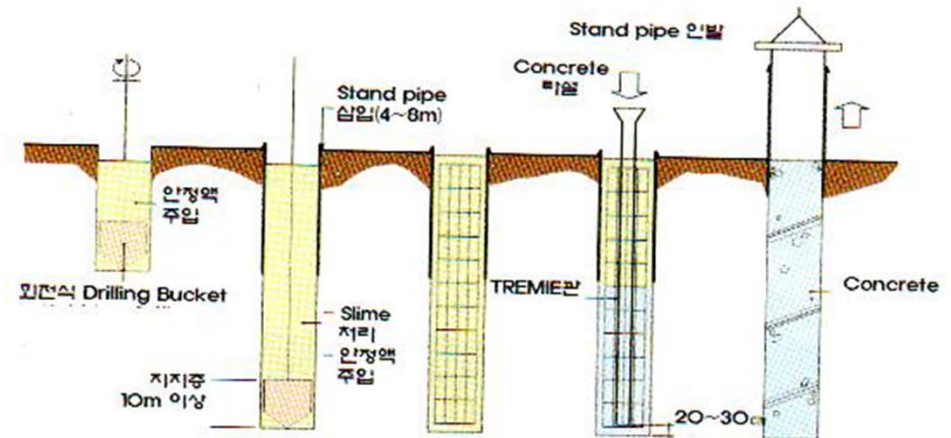
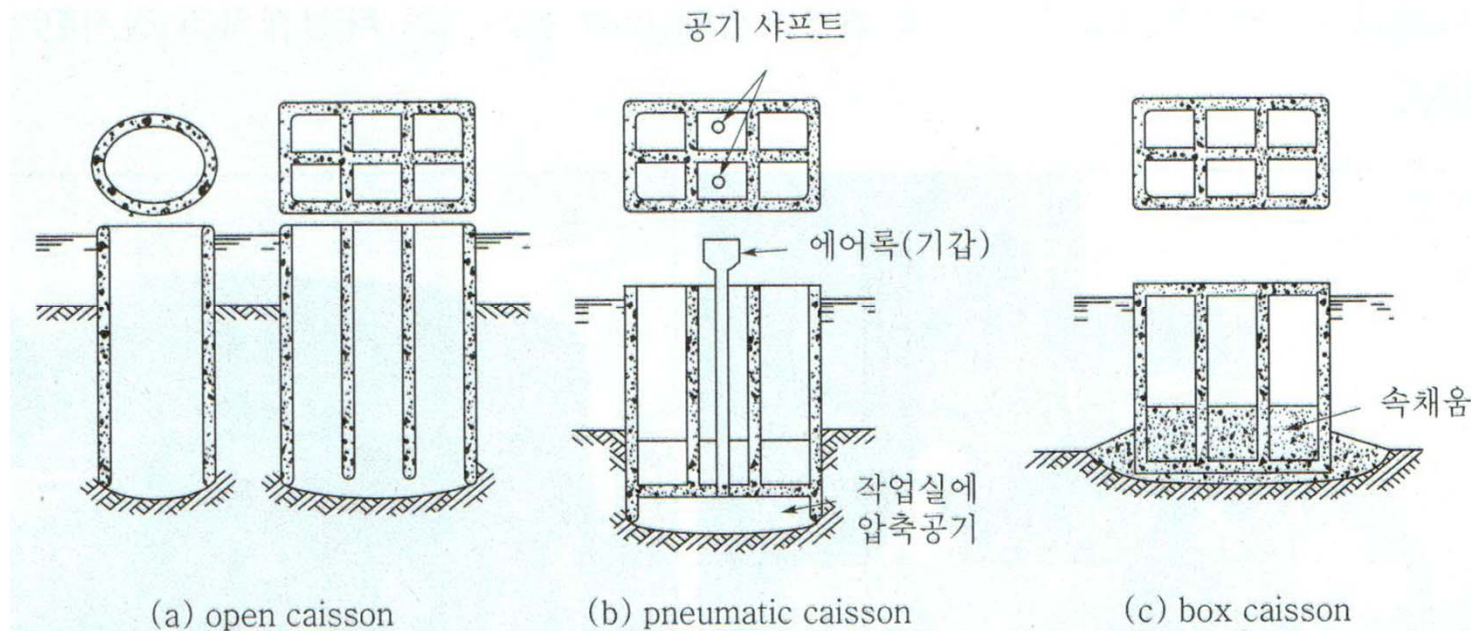

Caissons Foundation

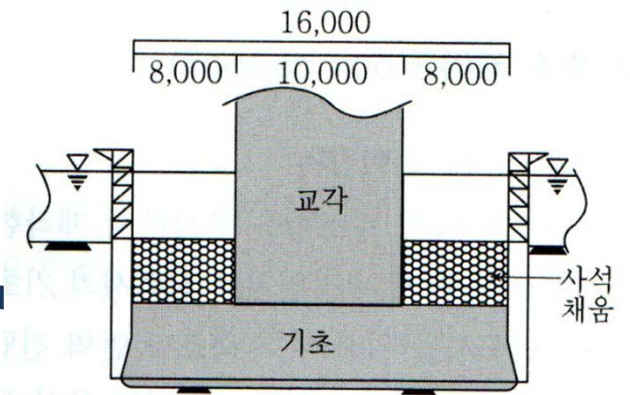

- **Open caisson (well foundation)**

- 철근콘크리트, 강재 등으로 제작된 개방단면을 가진 원형이나 상자형 구조물 내부의 토사를 굴착하면서 우물통의 자중 및 재하하중에 의하여 침하시키는 공법. 침하가 완료되면 우물통 내부를 콘크리트, 모래 등으로 속채움하고서 상부 구조물을 구축.
- Good for bridge piers/columns (used for Seohae bridge)

- No limit to drilling depth
- Relatively economical and easily operated
- Can disturb adjacent soil structure
- Can incline due to settlement
- Difficult to optimize quality of underground concrete

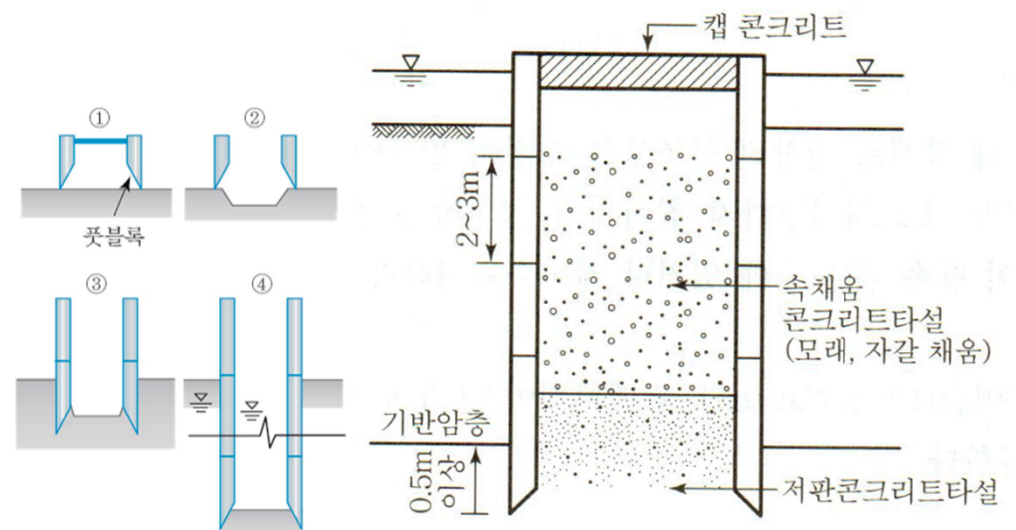

Caissons Foundation

- **Pneumatic caisson**

- 지상에서 제작된 케이슨을 현장에 운반하여 거치시킨 후에 케이슨 하부에 설치된 작업실에 지하수압에 상응하는 압축공기를 송기하여 지하수나 해수의 침입을 방지하면서 인력과 굴착장비로 지반을 굴착하여 케이슨을 지중에 침설시키는 공법
- Bridges, tunnels, subways, roadbed

- Good workability in dry working conditions
- Good to check underground conditions
- Stable with less movement and inclination
- Heaving/boiling protection
- **Difficult working in a deep depth (35-40m)**
- **Increase labor cost**
- **Cause of caisson disease**

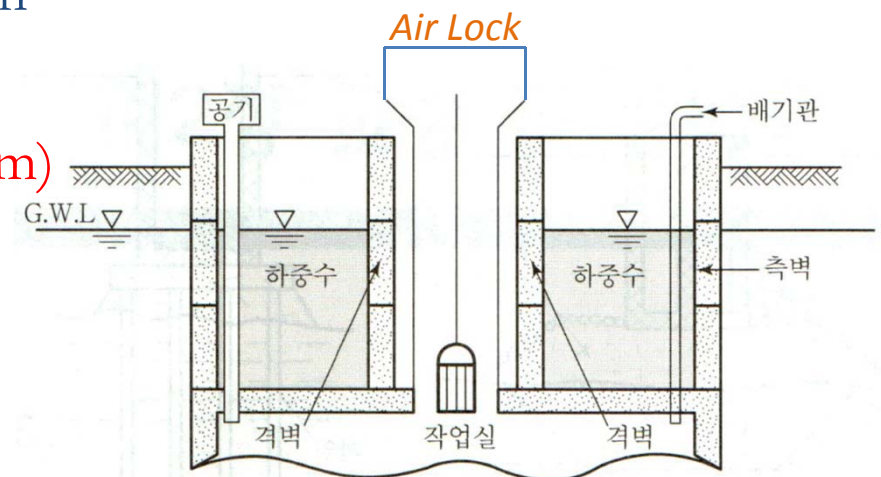

Caissons Foundation



DCM



SCP

- **Box caisson**

- 케이슨 바닥부가 폐쇄되어 있는 상자형 케이슨이며 일반적으로 육상 제작장에서 제작하여 설치 위치로 이동시킨 후에 케이슨 내부에 모래, 자갈, 물 또는 콘크리트를 채워서 케이슨을 수직으로 침강시킴
- Harbor dock, breakwater(방파제)
- Made by reinforced-concrete, concrete, iron
- Good lateral resistance
- Good for quality control during manufacturing
- Cheaper
- Horizontal leveling before settlement
- Consider underground scouring(세굴)

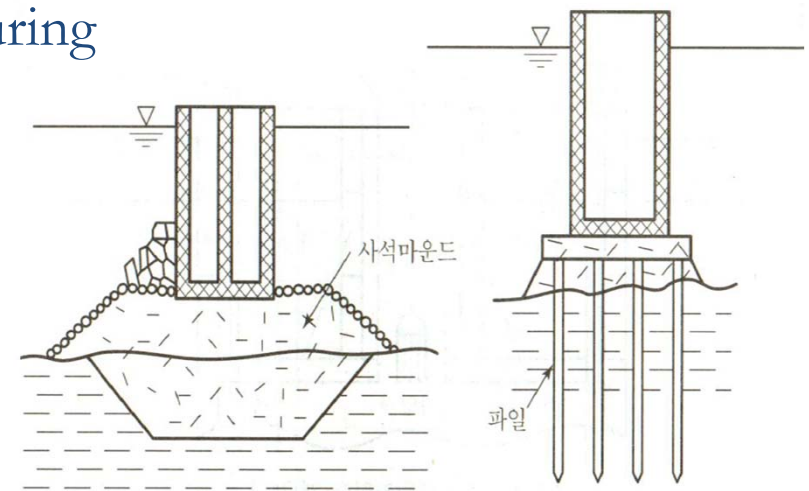

DCM(Deep Cement Mixing): 원지반과 시멘트를 섞어서 고결하여 말뚝을 만드는 것

SCP(Sand Compaction Pile): 모래다짐말뚝, 원지반에 모래를 압입하여 다짐말뚝을 조성

Caissons Foundation



DCM



SCP

