

# Detection and Measurement of Radiation

**Fall, 2019**

**Kyoung-Jae Chung**

***Department of Nuclear Engineering***

**Seoul National University**

# Introduction

- Radiation detectors of a wide variety are used for detecting, measuring, characterizing, and classifying radiation emissions.
- The three main functions that characterize a radiation detector are (1) a radiation absorber, (2) an observable phenomenon from the interaction, and (3) a method to measure the observable.
- Commonly used detectors

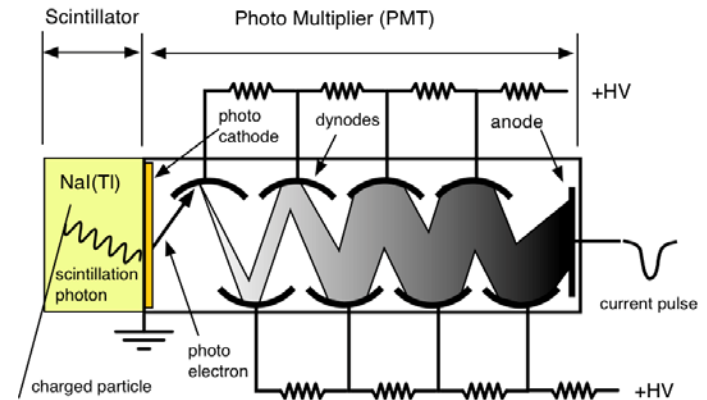
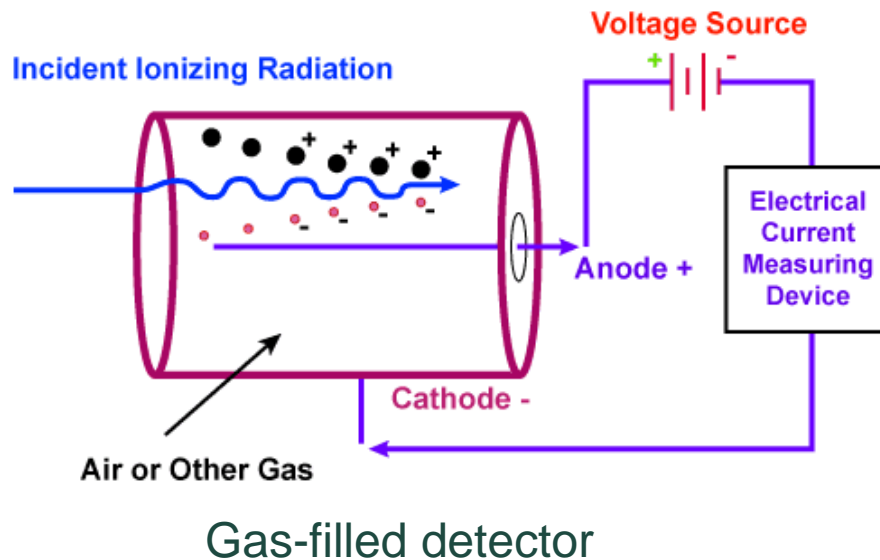

Scintillation detector

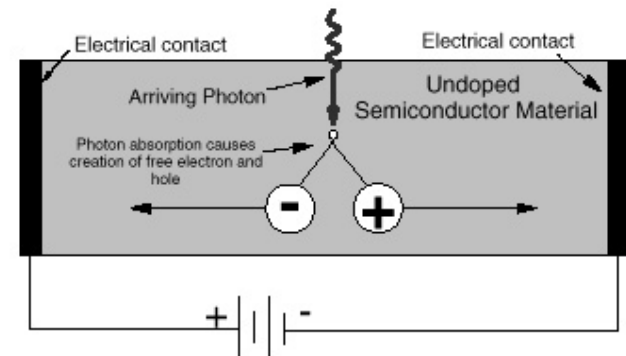

Semiconductor detector

# Gas-filled detectors

- Radiation passing through a gas can **ionize the gas molecules**, provided the energy it delivers is higher than the ionization potential of the gas. The charge pairs thus produced can be made to move in opposite directions by the application of an external electric field, resulting in a measureable electrical pulse. This process has been used to construct the so-called gas-filled detectors.

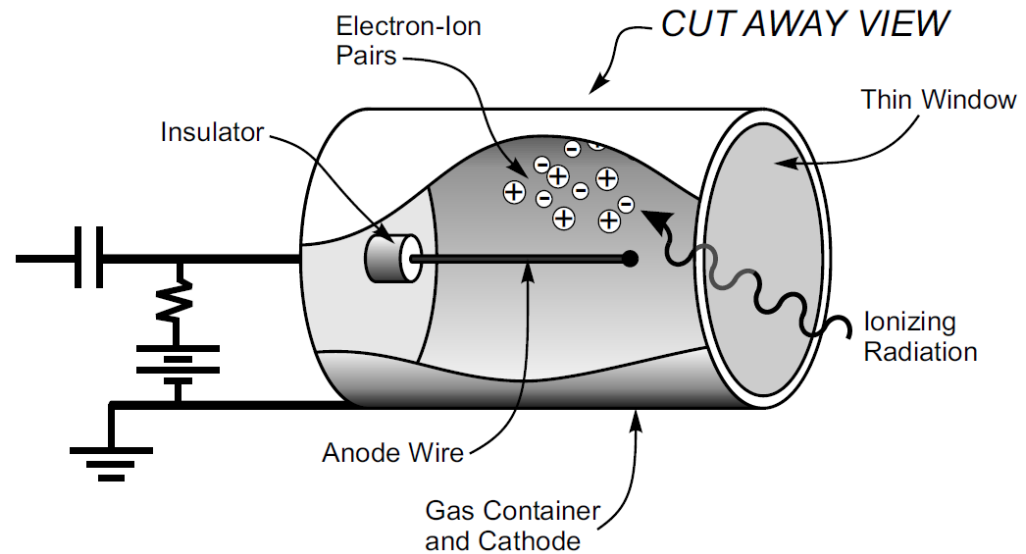
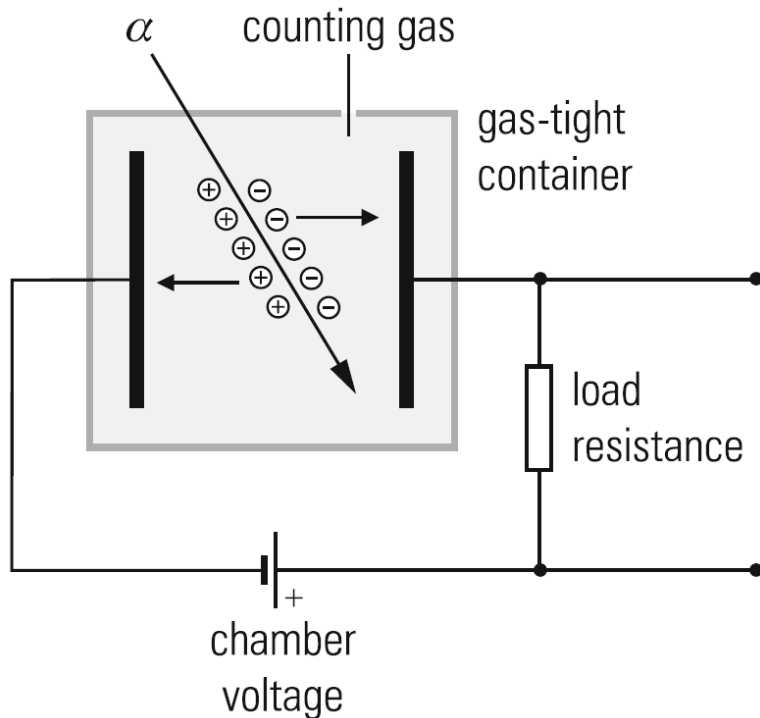

# Production of electron-ion pairs

- W-value: **the average energy needed to create an electron-ion pair in a gas**. It is significantly higher than the first ionization potential for gases, implying that not all the energy goes into creating electron-ion pairs.
- The charges created by the incident radiation are called **primary** charges to distinguish them from the ones that are indirectly produced in the active volume. The production mechanisms of these secondary charge pairs are similar to those of primary charges except that they are produced by ionizations caused by primary charge pairs and not the incident radiation.

| Gas             | Z  | Density<br>( $\times 10^{-4}$ g/cm <sup>3</sup> ) | $I_e$<br>(eV) | W<br>(eV/pair) | dE/dx<br>(keV/cm) | $n_p$<br>(ip/cm) | $n_t$<br>(ip/cm) |
|-----------------|----|---|---------------|----------------|-------------------|------------------|------------------|
| H <sub>2</sub>  | 2  | 0.8   | 15.4          | 37             | 0.34              | 5.2              | 9.2              |
| He              | 2  | 1.6   | 24.6          | 41             | 0.32              | 5.9              | 7.8              |
| N <sub>2</sub>  | 14 | 11.7  | 15.5          | 35             | 1.96              | 10               | 56               |
| O <sub>2</sub>  | 16 | 13.3  | 1.2           | 31             | 2.26              | 22               | 73               |
| Ne              | 10 | 8.4   | 21.6          | 36             | 1.41              | 12               | 39               |
| Ar              | 18 | 17.8  | 15.8          | 26             | 2.44              | 29               | 94               |
| Kr              | 36 | 34.9  | 14.0          | 24             | 4.60              | 22               | 192              |
| Xe              | 54 | 54.9  | 12.1          | 22             | 6.76              | 44               | 307              |
| CO <sub>2</sub> | 22 | 18.6  | 13.7          | 33             | 3.01              | 34               | 91               |
| CH <sub>4</sub> | 10 | 6.7   | 10.8          | 28             | 1.48              | 46               | 53               |

# Total number of electron-ion pairs produced

- For a particle that deposits energy  $\Delta E$  inside a detector, the  $W$ -value can be used to determine the total number of electron-ion pairs produced:

$$N = \frac{\Delta E}{W}$$

- In terms of stopping power:

$$N = \frac{1}{W} \frac{dE}{dx} \Delta x$$

- The number of electron-ion pairs produced per unit length of the particle track:

$$n = \frac{1}{W} \frac{dE}{dx}$$

- For a gas mixture

$$n = \sum_i x_i \frac{1}{W_i} \left( \frac{dE}{dx} \right)_i$$

For example, if a 3-MeV particle deposits all its energy in the detector, it will produce, on the average,

$$N = \frac{\Delta E}{W} \approx \frac{3 \times 10^6}{30} \approx 10^5 \text{ electron - ion pairs}$$

# Operation regions of gas-filled detectors

- **Recombination region:** When the voltage is very low, the electric field in the detector is not strong, electrons and ions move with relatively slow speeds, and **their recombination rate is considerable**. As  $V$  increases, the field becomes stronger, the carriers move faster, and their recombination rate decreases up to the point where it becomes zero. Then, all the charge created by the ionizing radiation is being collected ( $V = V_1$ ).

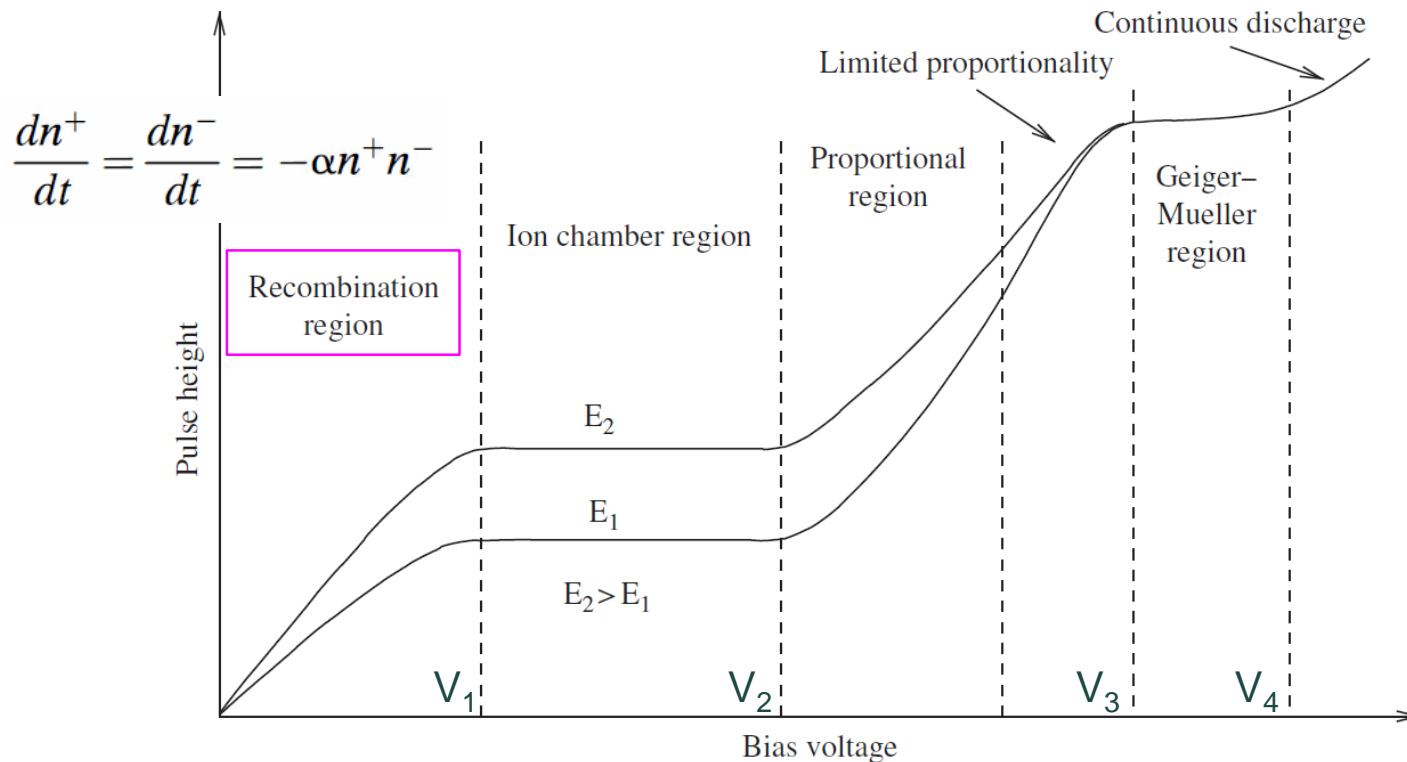

# Operation regions of gas-filled detectors

- **Ion chamber region:** In this region further increasing the high voltage does not affect the measured current since **all the charges being produced are collected efficiently by the electrodes**. The current measured by the associated electronics in this region is called the saturation current and is **proportional to the energy deposited by the incident radiation**. The detectors designed to work in this region are called **ionization chambers**.

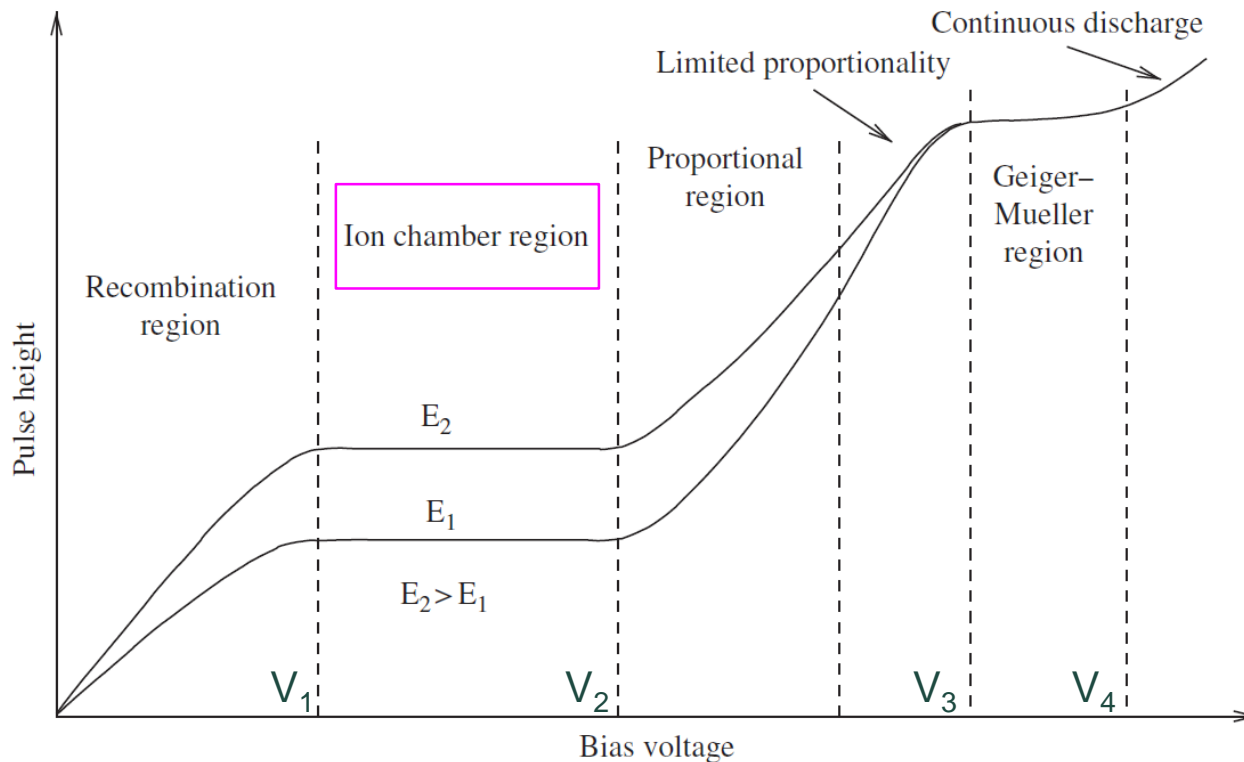

# Ionization chambers

- No charge multiplication takes place. The output signal is proportional to the particle energy dissipated in the detector; therefore, **measurement of particle energy is possible**. Since the signal from an ionization chamber is not large, only strongly ionizing particles such as alphas, protons, fission fragments, and other heavy ions are detected by such detectors. The voltage applied is less than 1000 V.

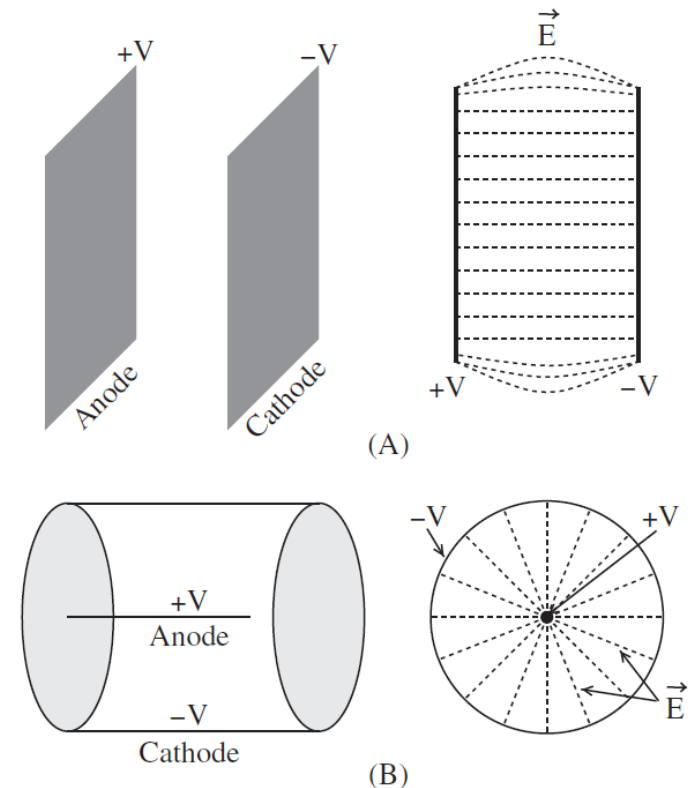
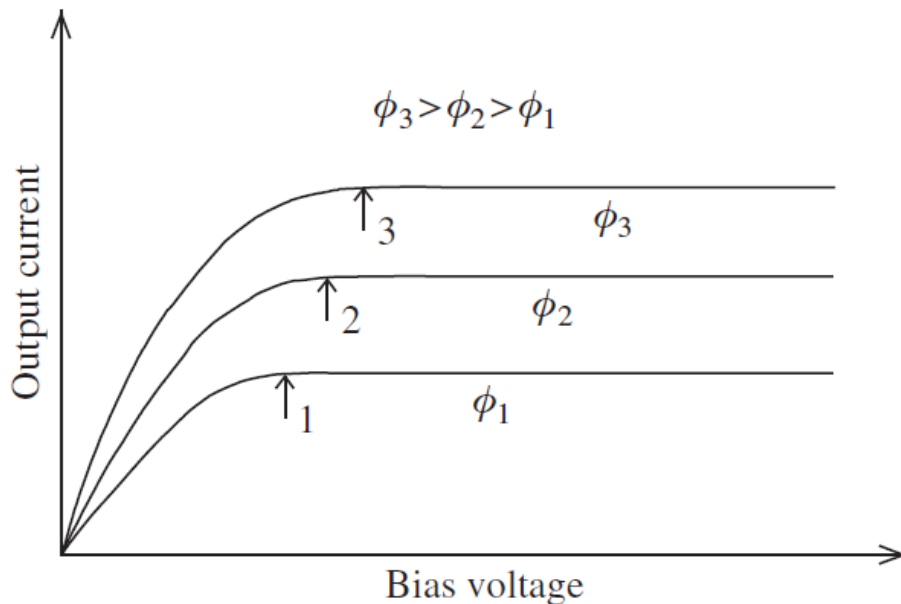



# Signal induction mechanism

- Induced charge and induced current

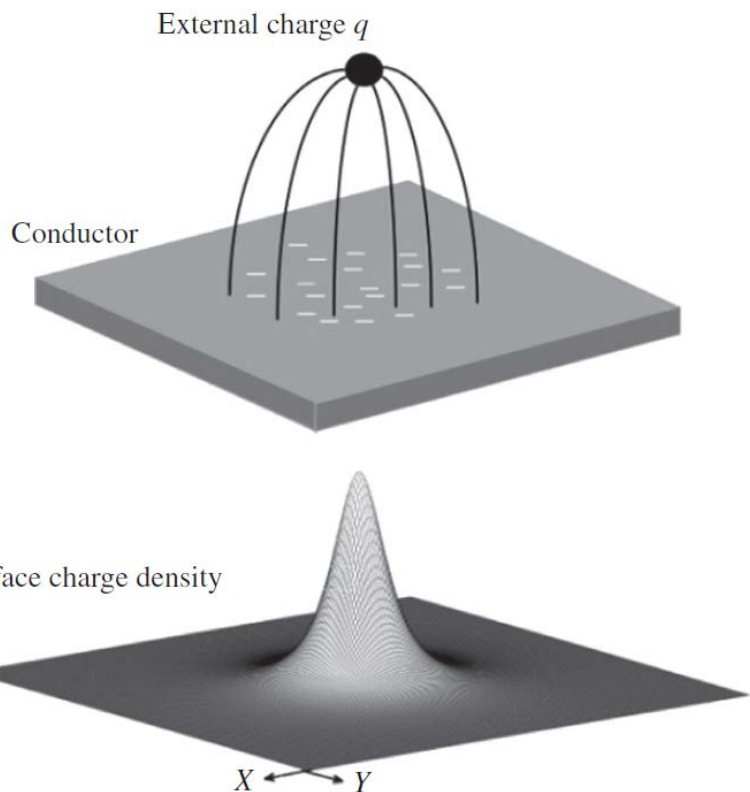

$$q_1 = -q \left( 1 - \frac{x_0}{d} \right)$$

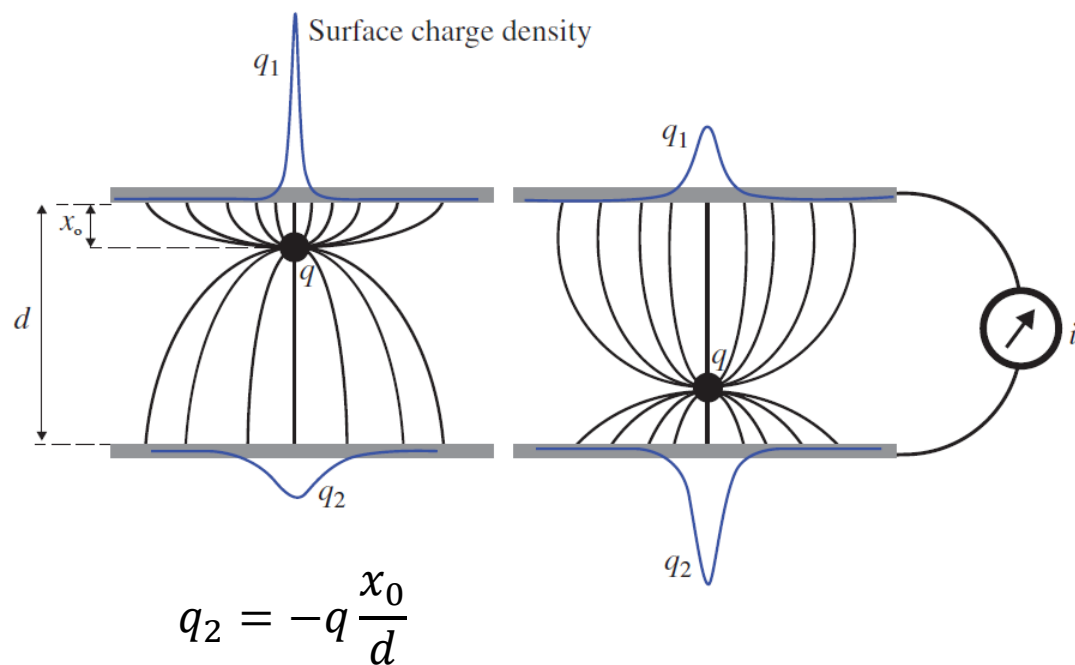

$$q_1 + q_2 = -q$$

# Shockley-Ramo theorem

- Shockley (1938), Ramo (1939): The induced current  $i$  between two electrodes separated by  $d$  by a moving point charge  $q$  with a velocity  $v$  is given by:

$$i = \frac{qv}{d}$$

## Energy conservation

$$qE \cdot dx = Vi \cdot dt \Rightarrow i = \frac{qEdx}{Vdt}$$

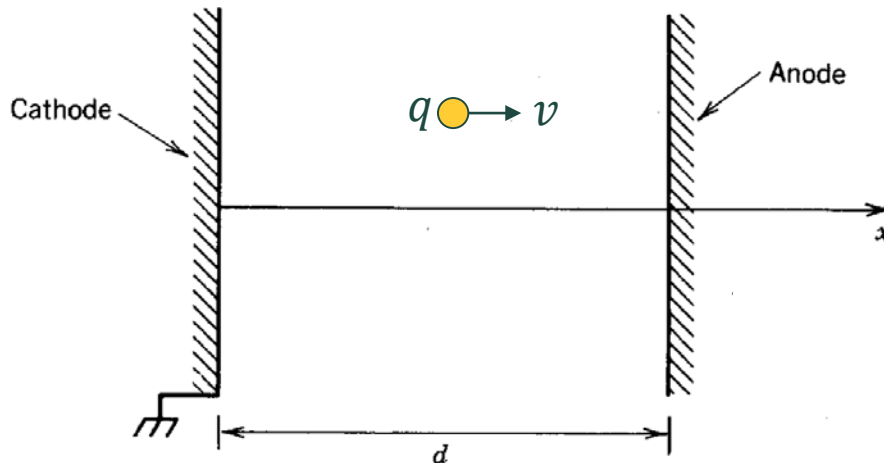

## Currents Induced by Electron Motion\*

SIMON RAMO†, ASSOCIATE MEMBER, I.R.E.

**Summary**—A method is given for computing the instantaneous current induced in neighboring conductors by a given specified motion of electrons. The method is based on the repeated use of a simple equation giving the current due to a single electron's movement and is believed to be simpler than methods previously described.

### METHOD OF COMPUTATION

The method is based on the following equation, whose derivation is given later:

$$i = E_x \epsilon v \quad (1)$$

where  $i$  is the instantaneous current received by the given electrode due to a single electron's motion,  $\epsilon$  is the charge on the electron,  $v$  is its instantaneous velocity, and  $E_x$  is the component in the direction  $v$  of that electric field which would exist at the electron's instantaneous position under the following circumstances: electron removed, given electrode raised to unit potential, all other conductors grounded. The equation involves the usual assumptions that induced currents due to magnetic effects are negligible and that the electrostatic field propagates instantaneously.

### INTRODUCTION

IN designing vacuum tubes in which electron transit-time is relatively long, it becomes necessary to discard the low-frequency concept that the instantaneous current taken by any electrode is proportional to the number of electrons received by

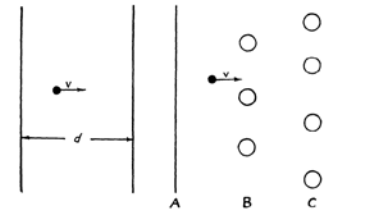

it per second. Negative grids, it is known, may carry current even though they collect no electrons and current may be noted in the circuit of a collector during the time the electron is still approaching the collector. A proper concept of current to an electrode must consider the instantaneous change of electrostatic flux lines which end on the electrode and the methods given in the literature for computing induced current due to electron flow are based on this concept.

A method of computing the induced current for a specified electron motion is here explained which is believed to be more direct and simpler than methods previously described. In the more difficult cases, in which flux plots or other tedious field-determination methods must be used, only one field plot is needed by the present method while the usual methods require a large number.

\* Decimal classification: R138. Original manuscript received by the Institute, September 16, 1938.

† General Engineering Laboratory, General Electric Company, Schenectady, N. Y.

### SIMPLE EXAMPLE

A simple example is offered in the computation of the instantaneous current due to an electron's motion between two infinite plates (Fig. 1). (The result is a starting point for the analysis of a diode, for example, when the transit-time is long.)

From (1) we obtain immediately

$$i = \epsilon v E_x = \frac{\epsilon v}{d}$$

In the literature<sup>1</sup> it is stated that this same result is deduced from image theory. This involves the setting up of an infinite series of image charges on each side of the plates for a given position of the electron and a consideration of the total flux crossing one of the planes due to the series of charges, a method which is lengthy and requires no little familiarity with methods of handling infinite series.

### THE GENERAL CASE

Consider a number of electrodes,  $A, B, C, D$ , in the presence of a moving electron (Fig. 2) whose path and instantaneous velocity are known. A tedious way to find the current induced in, say, electrode

<sup>1</sup> D. O. North, "Analysis of the effects of space charge on grid impedance," *Proc. I.R.E.*, vol. 24, pp. 108-158; February, 1936.

# Detectors as a signal generator

- Ionization detectors produce a current pulse in response to an interaction with the detector. Therefore, detectors can be considered as a **current source** in the circuit.
- The current pulse induced by the moving charge carriers on the detector's electrodes appears as a **voltage pulse** at the input of the readout electronics.

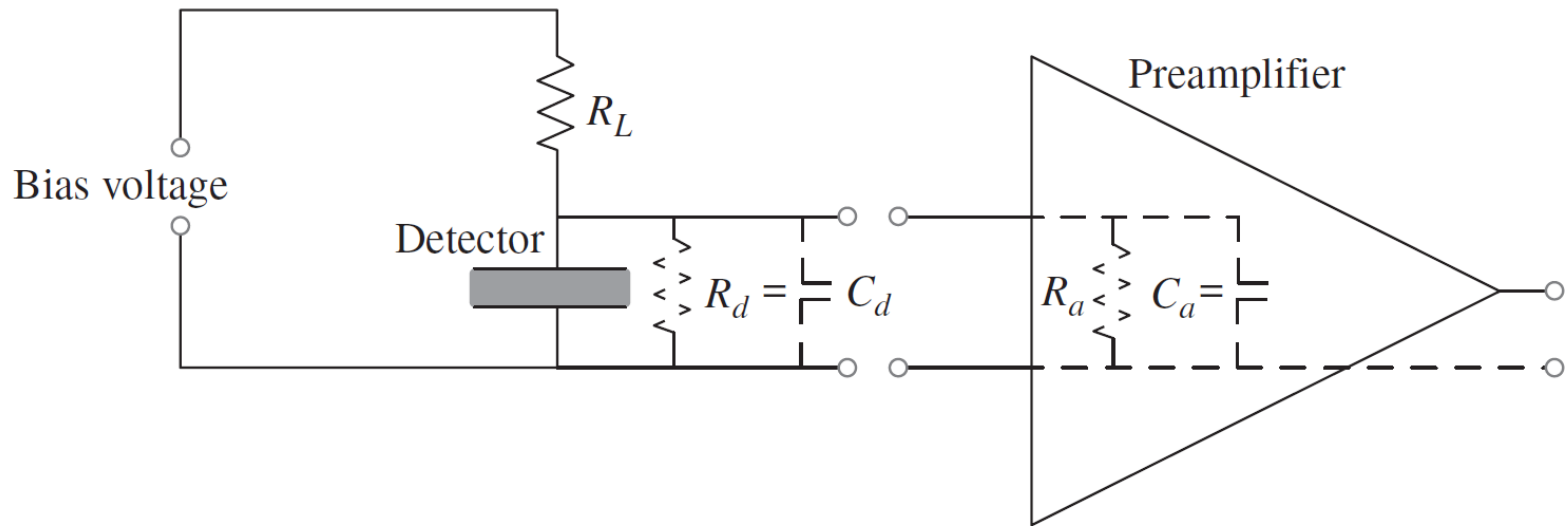

Equivalent circuit

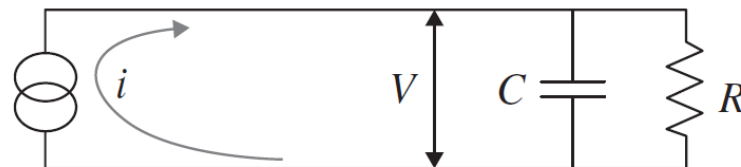

# Pulses from ionization detectors

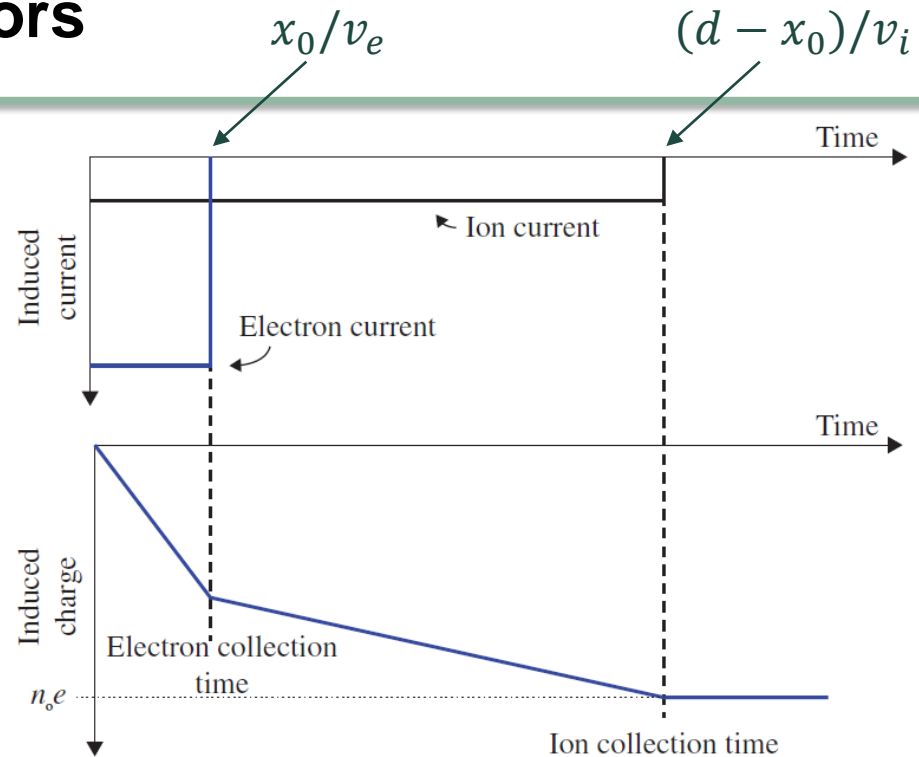
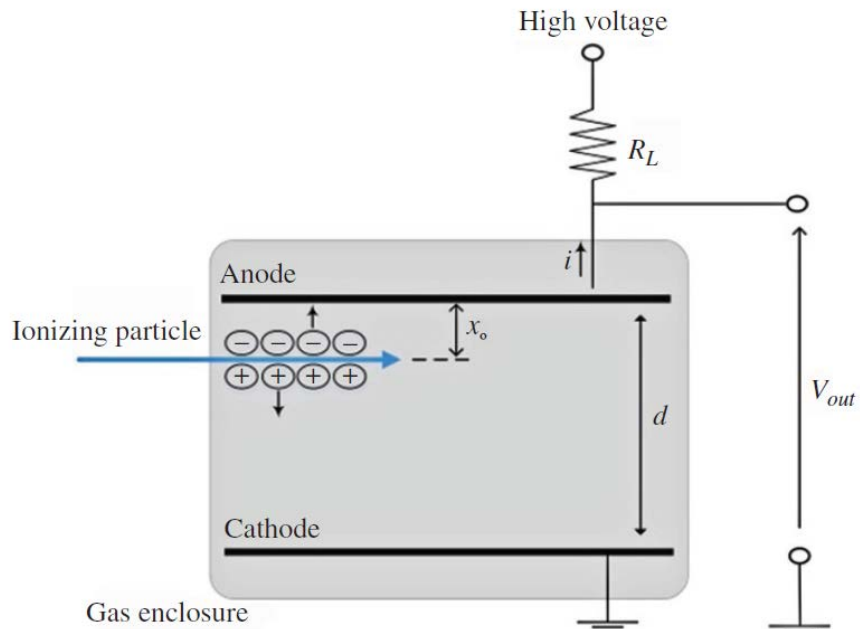

$$i(t) = i_e(t) + i_i(t) = \frac{n_0 e}{d} (v_e + v_i)$$

$$v_e = \mu_e E = \frac{e}{m_e \nu_m} E \sim 10^4 \text{ m/s}$$

$$Q(t) = \int (i_e + i_i) dt = \frac{n_0 e}{d} (v_e + v_i) t \quad \text{for } 0 \leq t \leq x_0/v_e$$

$$Q(t) = \frac{n_0 e}{d} x_0 + \frac{n_0 e}{d} v_i t \quad \text{for } x_0/v_e \leq t \leq (d - x_0)/v_i$$

# Output voltage pulse for different circuit time constants

- When the detector is connected to the measuring circuit, the equivalent input resistance,  $R$ , and capacitance,  $C$ , are obtained by combining all the resistors and capacitances at the input of the measuring circuit.
- The shape of a voltage pulse is a function of the time constant of the detector circuits.

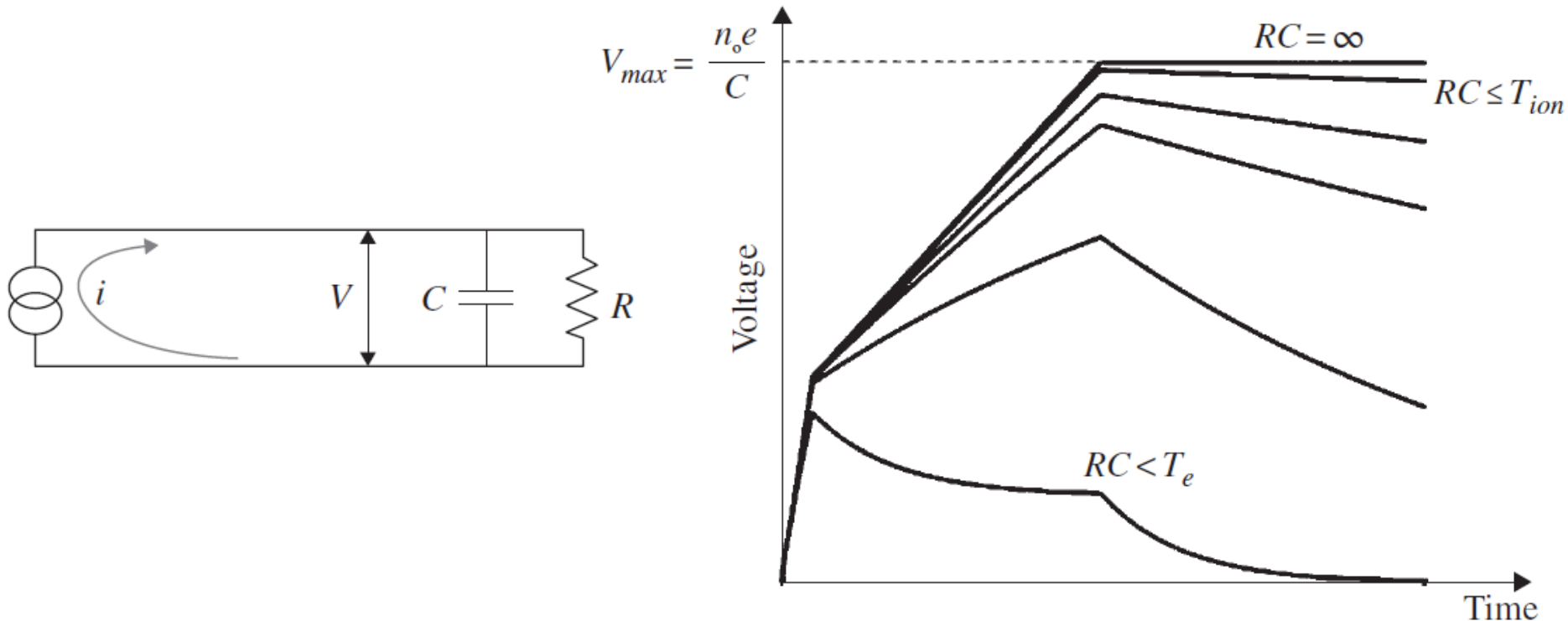

# Operation regions of gas-filled detectors

- **Proportional region:** The collected charge starts increasing because the electrons produce **secondary ionization** that results in charge multiplication. The charge multiplication factor—the ratio of the total ionization produced divided by the primary ionization—is, for a given voltage, is independent of the primary ionization. Thus the total number of charges produced after multiplication is proportional to the initial number of charges.

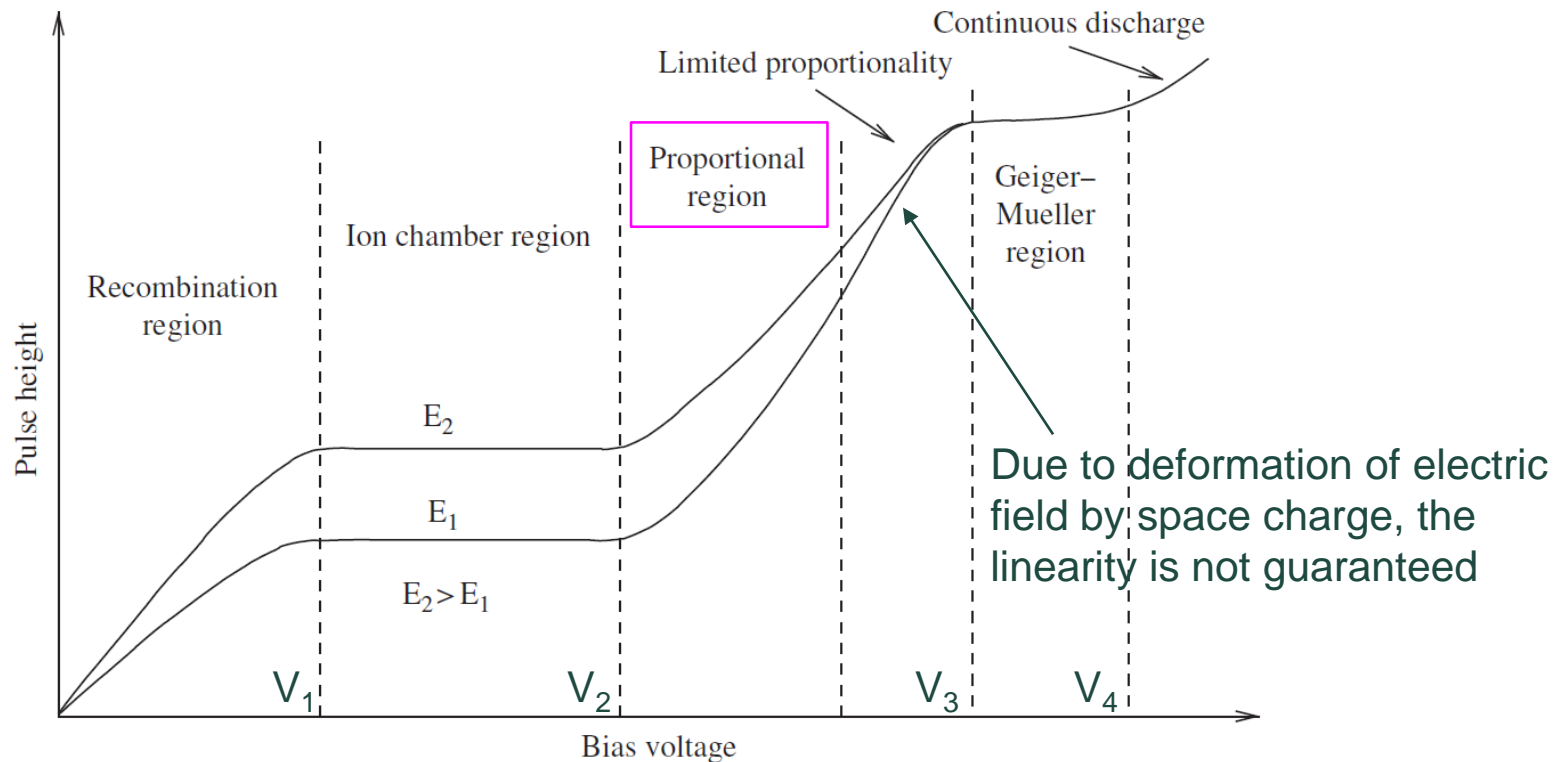

# Avalanche multiplication

- **Avalanche multiplication:** Due to the high electric field between the electrodes, the charges quickly gain energy between collisions. If the total energy of an electron or an ion becomes higher than the ionization potential of the gas atoms, it can ionize an atom, thus creating another charge pair.
- In uniform electric field, the change in the number of charge pairs per unit path length is simply proportional to the total number of charge pairs:

$$\frac{dn}{dx} = \alpha n$$

$$\alpha = \frac{1}{\lambda_{iz}} : \text{Townsend 1}^{\text{st}} \text{ ionization coefficient}$$

- Multiplication factor:  $M = \frac{n}{n_0} = e^{\alpha x}$

- For non-uniform field,  $M = \exp \left[ \int_{r_1}^{r_2} \alpha(x) dx \right]$

- The first Townsend coefficient is given by

$$\frac{\alpha}{p} = f \left( \frac{E}{p} \right) = A \exp \left[ - \frac{Bp}{E} \right]$$

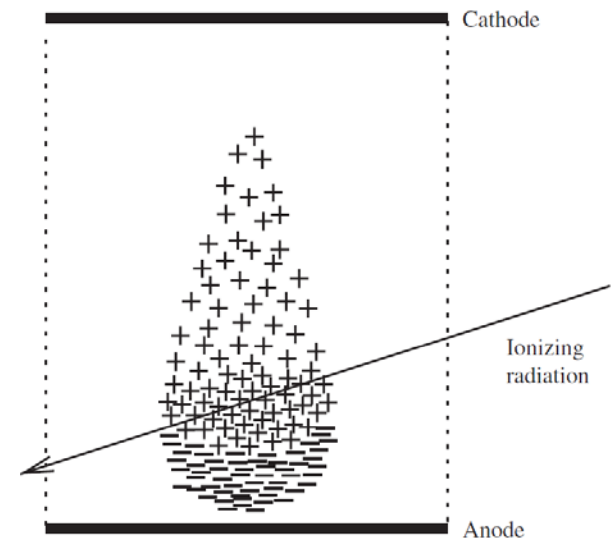

# Proportional counters

- Charge multiplication takes place, but the output signal is still proportional to the energy deposited in the counter. **Measurement of particle energy is possible.** Proportional counters may be used for the detection of any charged particle. **Identification of the type of particle is possible with both ionization and proportional counters.** An alpha particle and an electron having the same energy and entering either of the detectors will give a different signal. The alpha particle signal will be bigger than the electron signal. The voltage applied to proportional counters ranges between 800 and 2000 V.

$$i_e(t) = \frac{n_0 e v_e}{d} e^{\alpha x} = \frac{n_0 e v_e}{d} e^{\alpha v_e t}$$

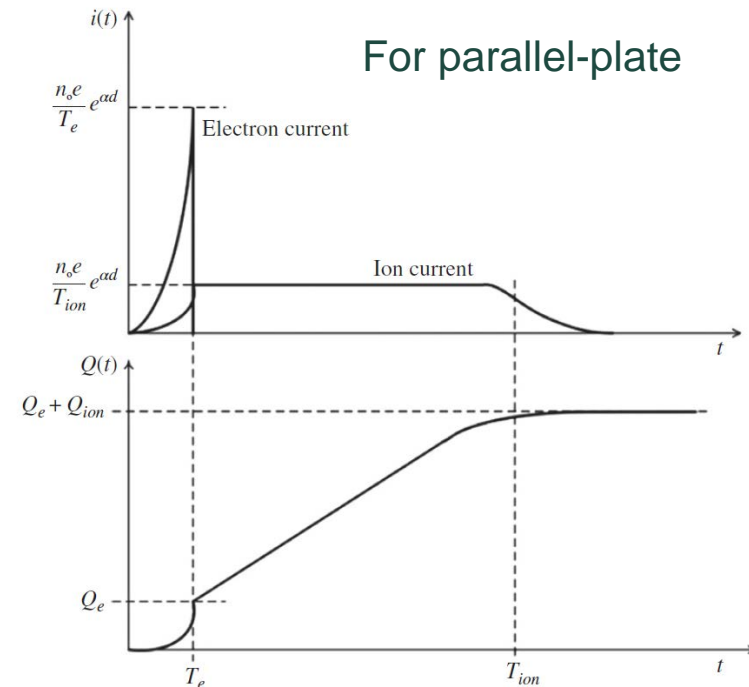
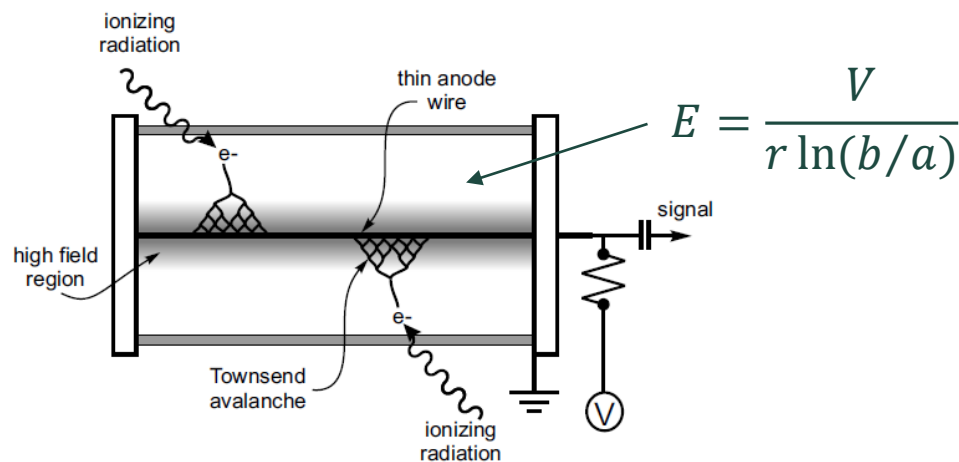



# Operation regions of gas-filled detectors

- **Geiger-Mueller region:** In this region, the electric field inside the detector is so strong that a single electron–ion pair generated in the chamber is enough to initiate an avalanche of electron–ion pairs. This avalanche will produce a strong signal with shape and height independent of the primary ionization and the type of particle, a signal that depends only on the electronics of the detector. Thus, the detectors operated in this region are not appropriate for spectroscopy.

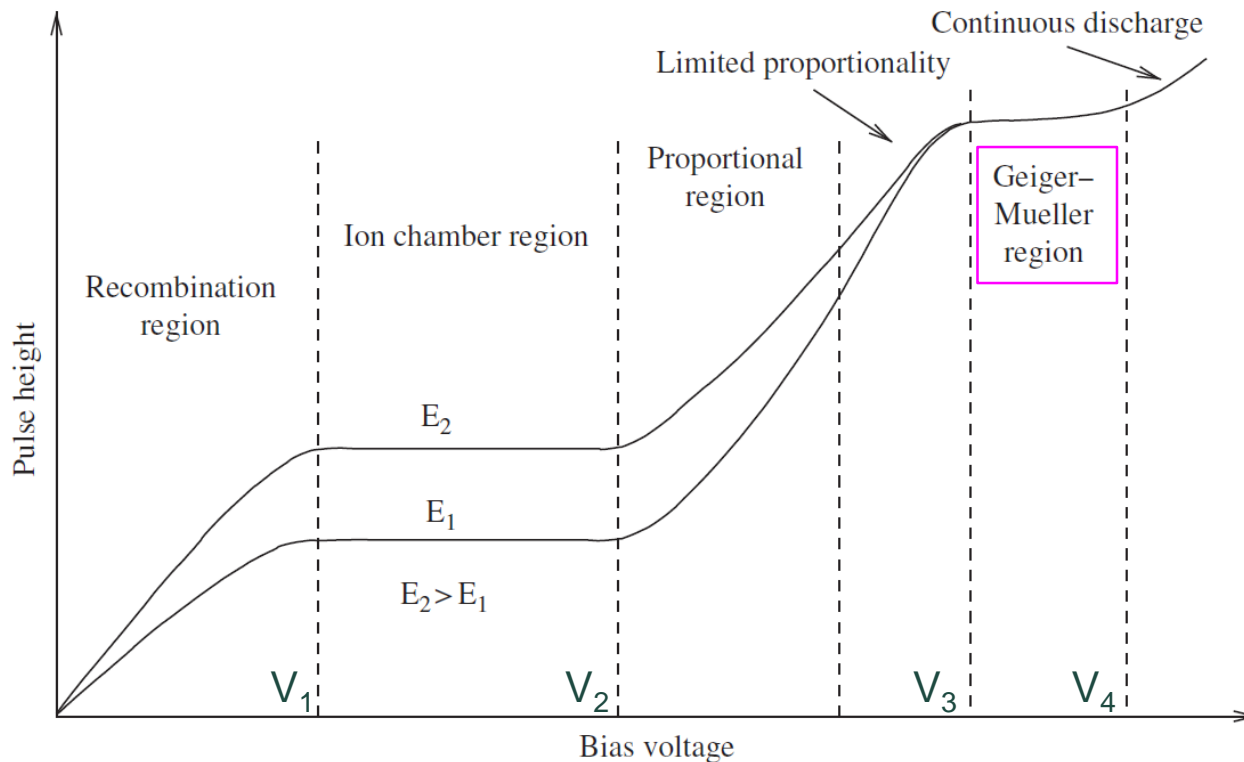

# GM counters

- Simple and provides a very strong signal. They can be used with any kind of ionizing radiation. The disadvantage of GM counters is that **their signal is independent of the particle type and its energy**. Therefore, a GM counter provides information **only about the number of particles**. The voltage ranges are 500 ~ 2000 V.

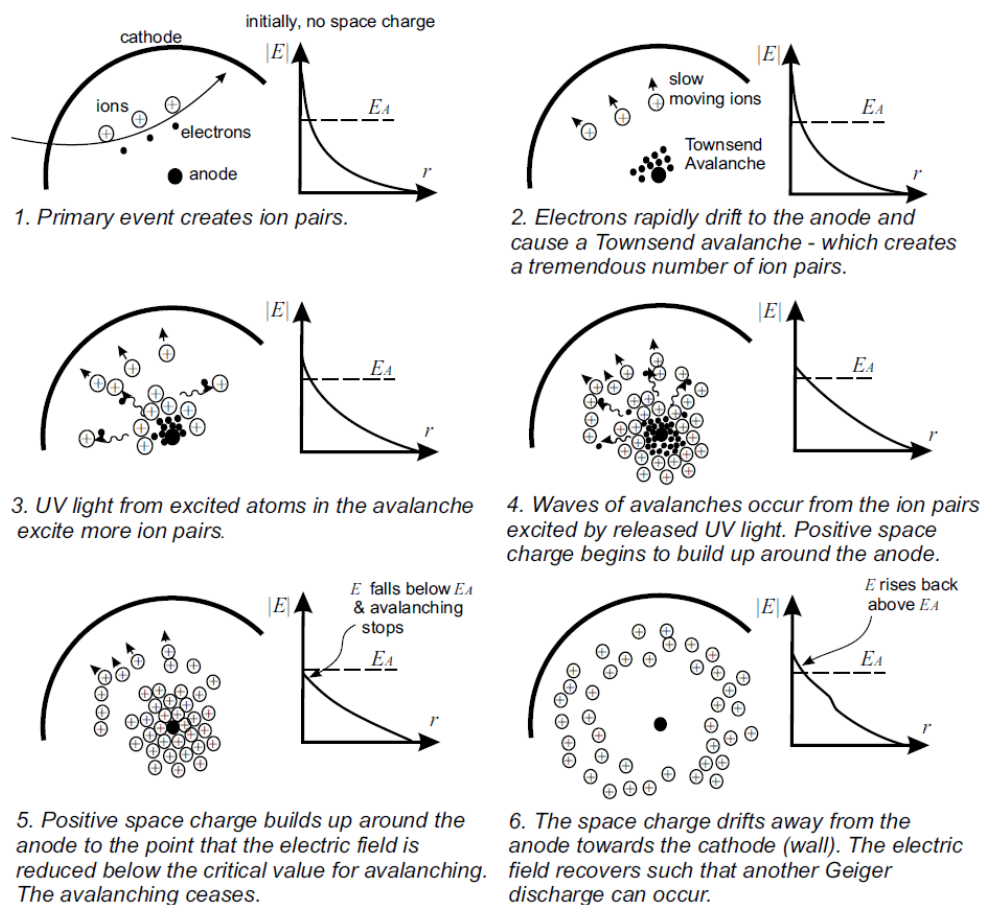

# Operating regimes of gas-filled detectors in a typical characteristic curve for gas discharges

Non-self-sustaining      Self-sustaining

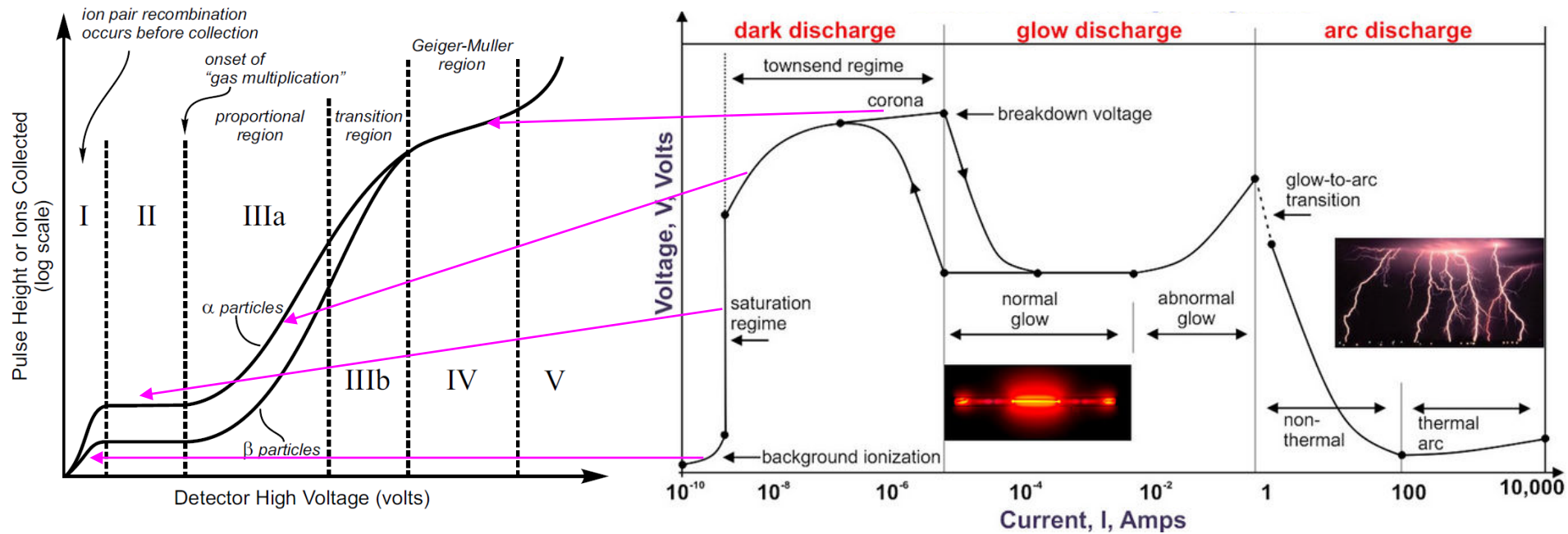

Radiation detection      Plasma generation

# Scintillation detectors

- Radiation detection is accomplished by the use of a scintillator material: a substance that emits light when struck by an ionizing particle. The scintillations emitted from the scintillator are then converted to an electrical signal by means of a photodetector.
- They can be broadly categorized into organic and inorganic scintillators.
  - **Organic scintillators** are composed of low atomic number elements and, therefore, are more suitable for neutron and charged particle detection.
  - **Inorganic scintillators** normally contain a large fraction of atoms with a high atomic number and, therefore, are suitable for gamma-ray detections.

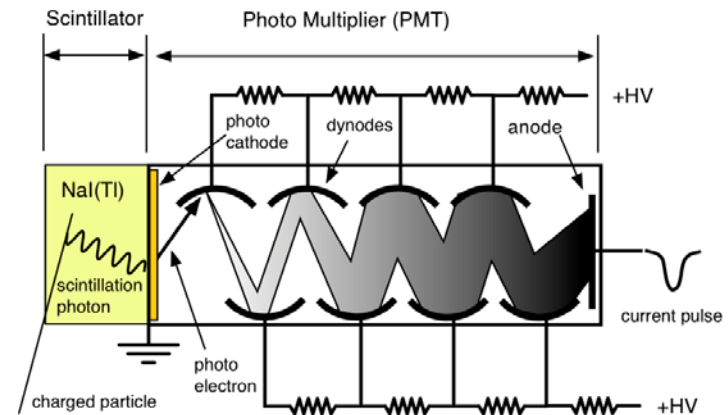
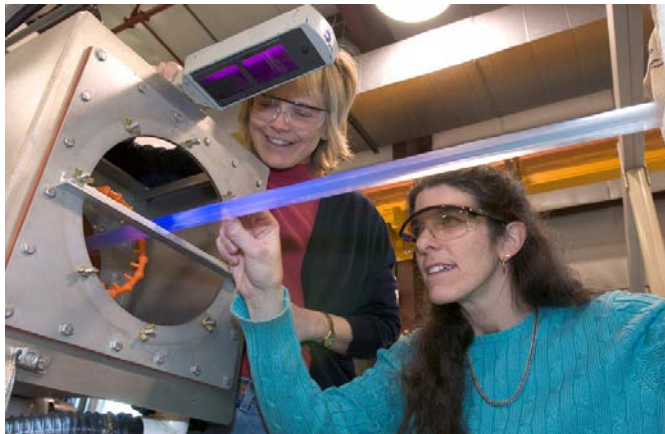

# Electronic band structure

- In solid-state physics, the electronic band structure (or simply band structure) of a solid describes the range of energies that an electron within the solid may have (called energy bands, allowed bands, or simply bands) and ranges of energy that it may not have (called band gaps or forbidden bands).

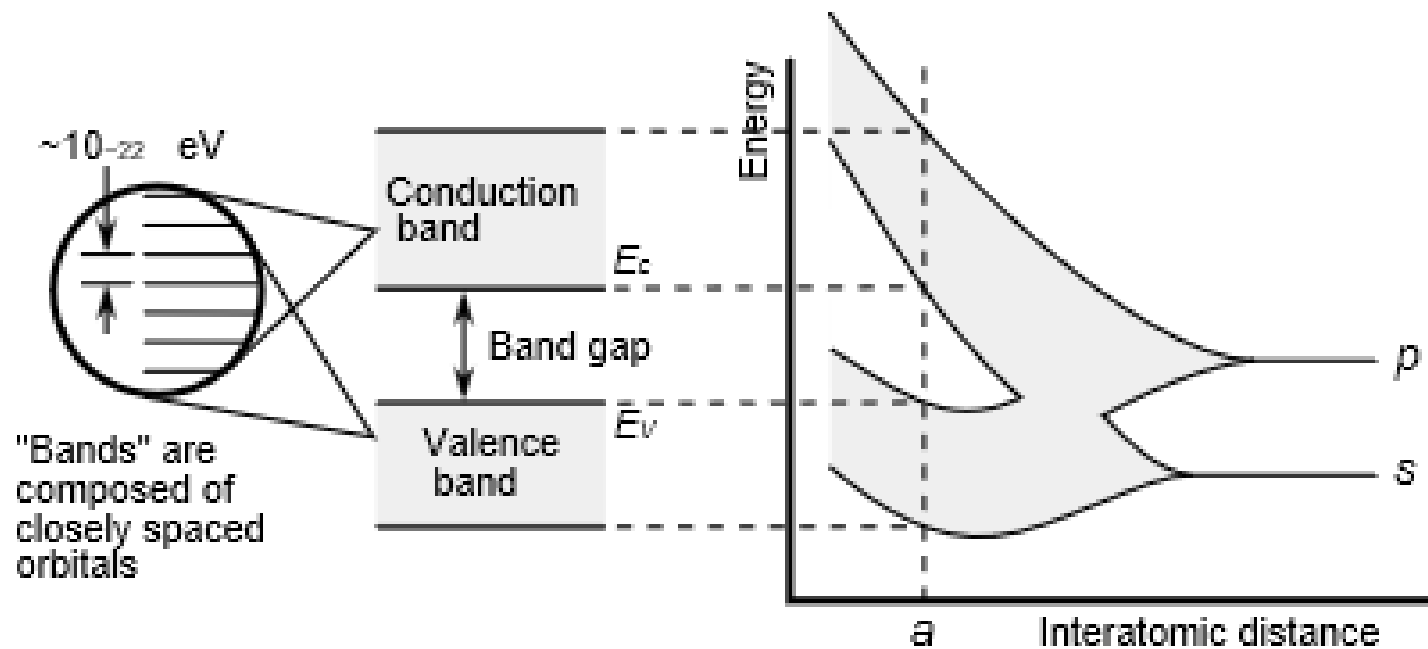

# Inorganic scintillators

- Inorganic scintillators depend primarily on the crystalline energy band structure of the material for the scintillation mechanism.
- The absorption of energy can elevate electrons from the valence band to the conduction band, leaving a hole in the valence band. The return of an electron to the valence band leads to the emission of a de-excitation photon.
- The efficiency of light emission can be significantly increased by adding a small amount of impurities, called activators, to the crystal.
- The main properties are scintillation efficiency (the ratio of the energy of the emitted photons to the total absorbed energy), light output (the number of photons per MeV of energy absorbed in the detector), emission spectrum, and decay time of scintillation light.
- NaI(Tl): thallium-doped sodium iodide
  - Light output: ~38000 photons/MeV
  - Most probable wavelength: ~415 nm
  - Decay time: ~230 ns
- Others: CsI(Na), CsI(Tl), BGO (bismuth germanate), LaBr<sub>3</sub>,...

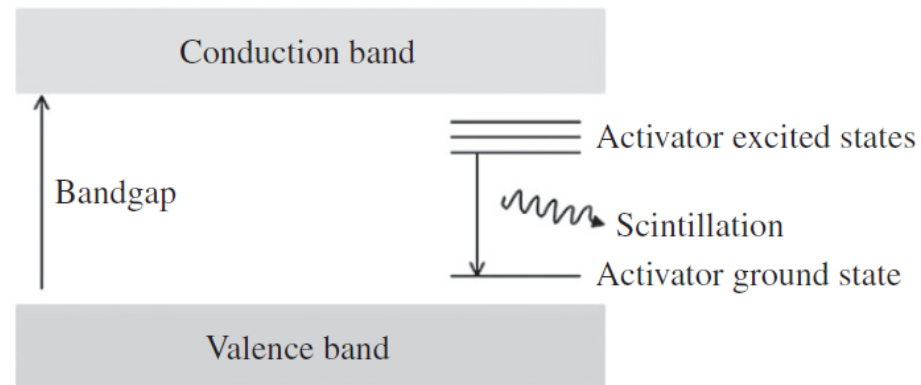

# Organic scintillators

- The scintillation mechanism in organic materials arises from transitions in the energy levels of a single molecule, and therefore organic scintillators can be found independently of the physical state (very fast: a few ns).

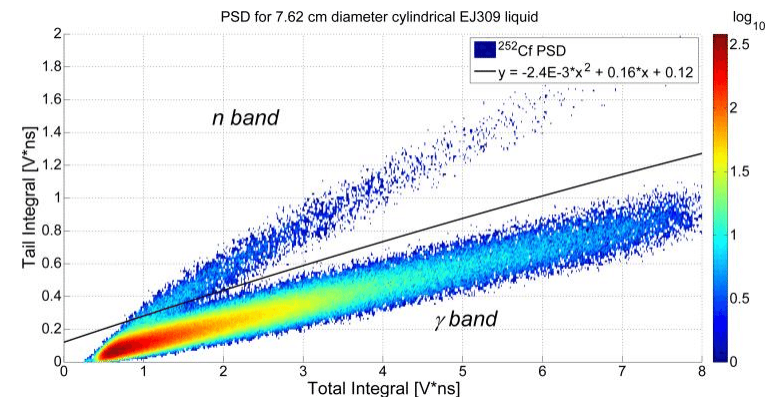
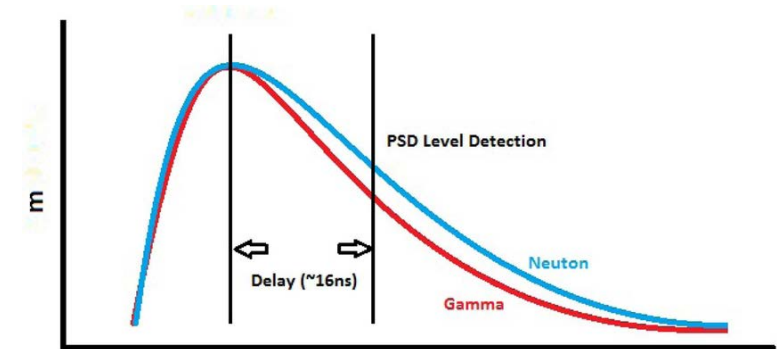
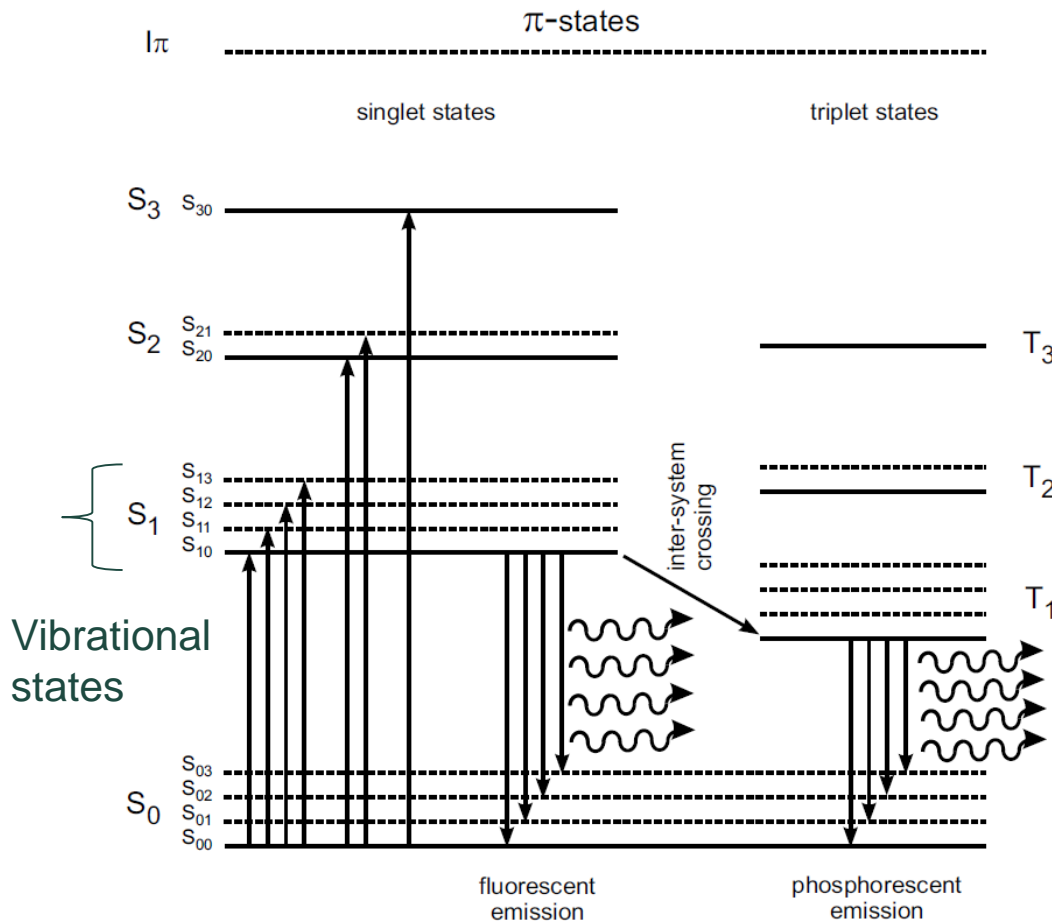

# Light collection

- Photomultiplier tube (PMT)

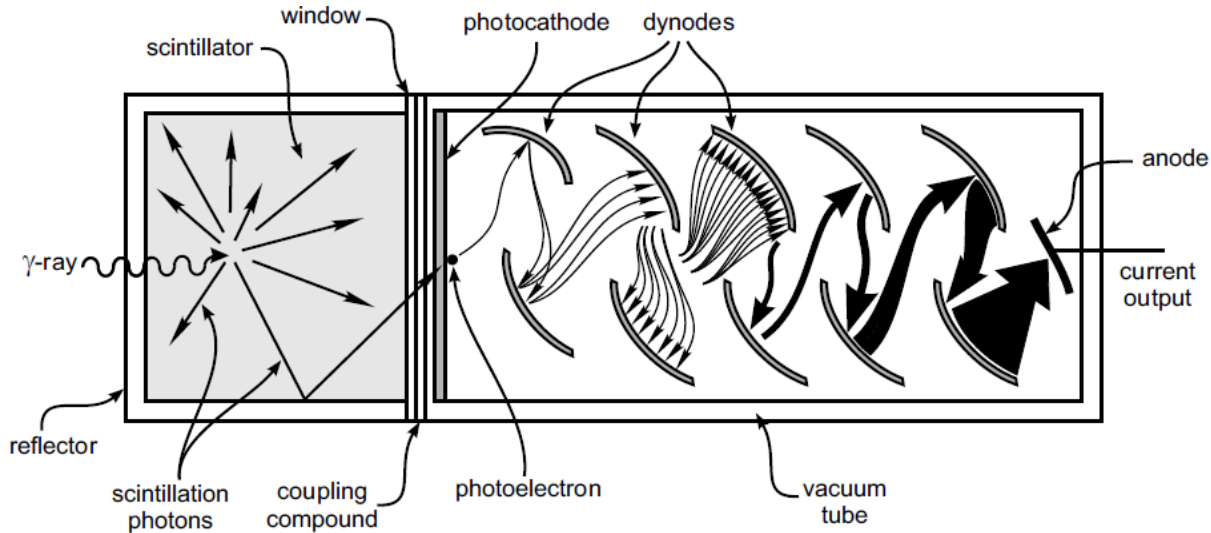

# of dynodes

$$Q = qN_0G^n$$

↑  
Gain ( $\gamma_e$ )

- Microchannel plate (MCP)

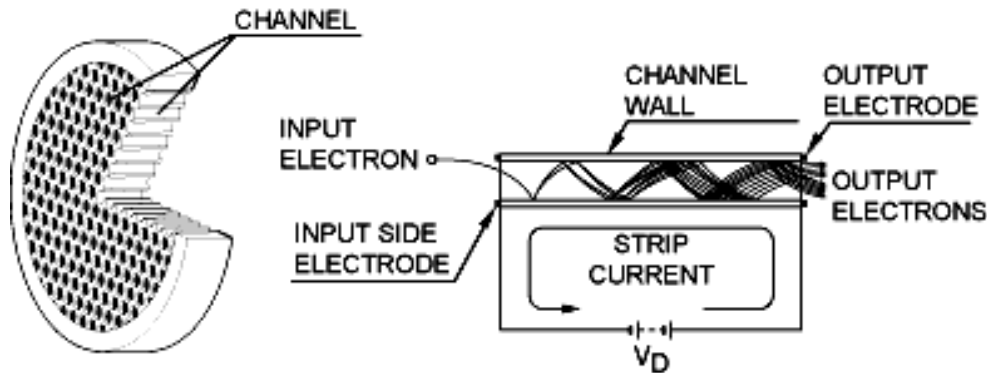



# Semiconductor detectors

- The operation of a semiconductor detector combines the concepts of the charge excitation method in a crystalline inorganic scintillator and the charge collection method of a gas-filled ion chamber.
- High energy resolution
- High electron-hole pairs ( $W_i = 3\sim 5 eV$ )
- High mobility

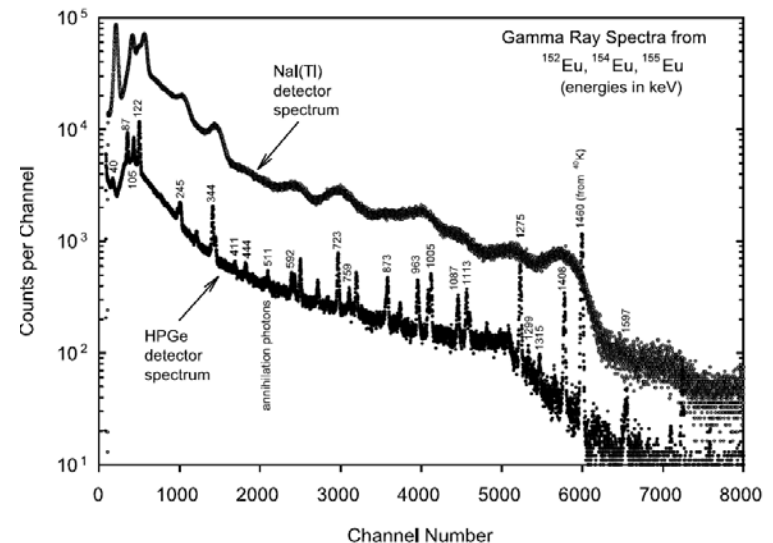
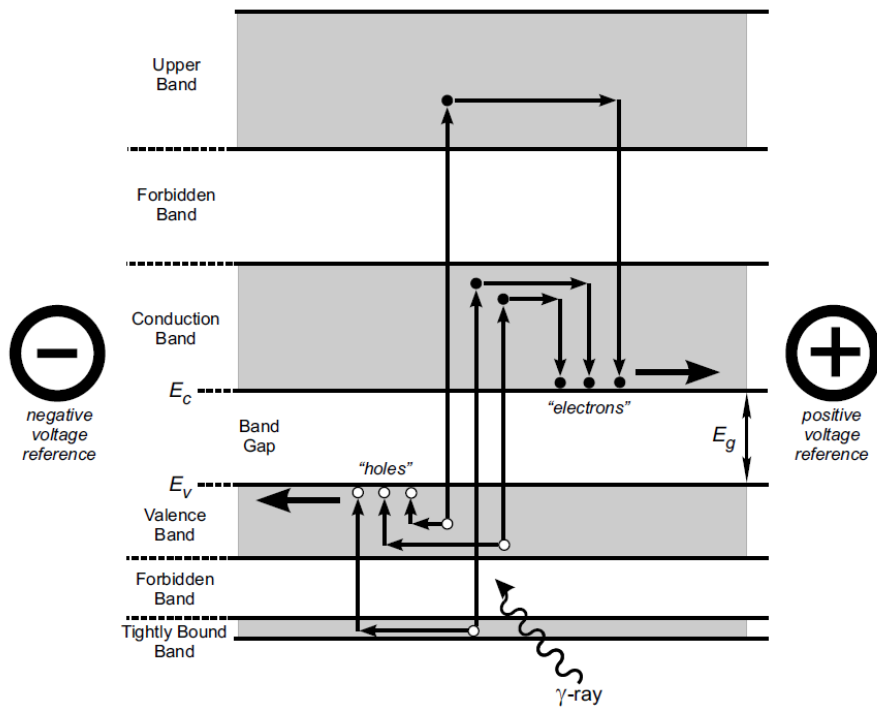
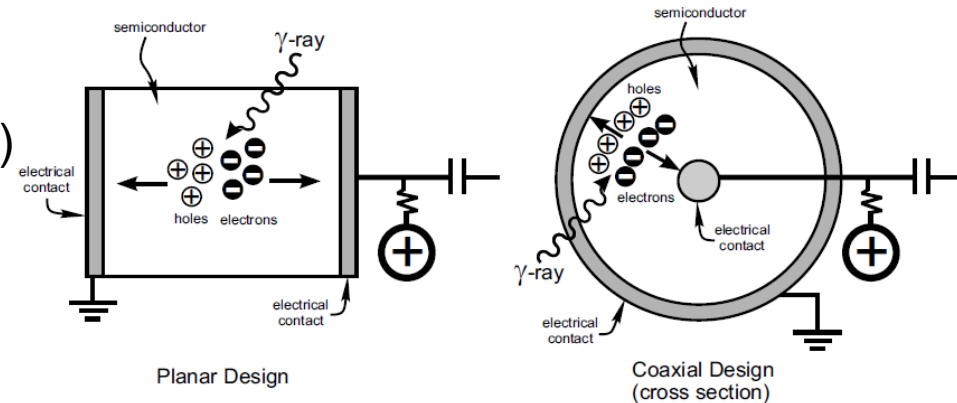

# Detection equipment

- Instrumentation for the nuclear industry was standardized in 1969 according to the U.S. Atomic Energy Commission (now the Department of Energy) to what are referred to as Nuclear Instrument Modules (NIM).
- Important components
  - Preamplifier: (1) to provide low noise coupling of the detector to the string of amplifier and readout electronics, and (2) to produce a first stage of signal amplification.
  - Amplifier: (1) pulse shaping and (2) amplification.
  - Discriminator/SCA: passing only pulses of certain voltages that are of interest.
  - Multichannel analyzer (MCA): separates by amplitude (energy) the voltage pulses exiting the amplifier unit into numerous bins.

