



Week 13
Tunnel

457.308 Construction Methods and Equipment
Department of Civil and Environmental Engineering
Seoul National University

Prof. Seokho Chi

shchi@snu.ac.kr

건설환경공학부 35동 304호

Tunnel Project Planning

- **Consideration**

- Ground condition avoids unstable grounds and locations that experienced any disaster
- Economical construction and safety during construction
- Efficient maintenance facility for ventilation and lighting, emergency control
- Traffic management and riding quality
- Sustainability: Harmony with ambient natural environment

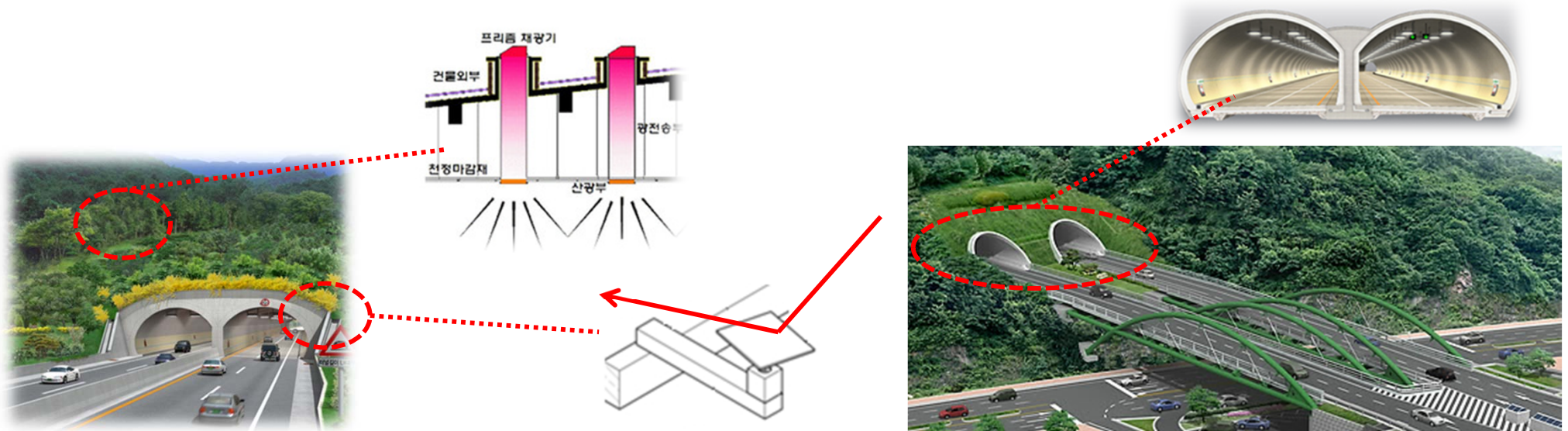

Tunnel Project Planning

- **평면선형**

- 지반조건이 양호하고 유지관리가 용이하며 주변 환경에 미치는 영향이 적은 곳을 통과하도록 결정
- 편압이 예상되거나 습곡지역/용출수가 많을 것으로 판단되는 지역, 안정성이 우려되는 단층 및 파쇄대지역 등은 피하도록 함.
- 터널 앞/뒤로 접속하는 구간을 포함한 전체적인 선형을 유지하고 운전자의 심리적인 폐쇄감과 압박감을 고려하여 평면선형은 가능한 직선으로 계획

- **종단선형**

- 공사 중이나 개통 후의 주행 안정성, 환기, 방재설비 등을 종합적으로 고려하고 차량의 주행 안전성이 확보되는 완만한 경사로 함.
- 터널 개통 후에 터널 내부의 용수를 종단 배수구에 의하여 자연 유출시키려면 0.1% 이상의 경사가 필요
- 시공 중에 발생하는 용수의 자연배수를 위해서 용수가 적은 경우에는 0.3%, 상당히 많은 경우에는 0.5% 정도의 경사가 필요
- 종단경사를 지나치게 크게 하면 시공 중의 버력처리나 자재 운반 등의 작업 능률이 떨어지고 개통 후에도 교통용량이 저하되므로 0.3-2%의 완만한 경사를 가지도록 함.

Tunnel Project Planning

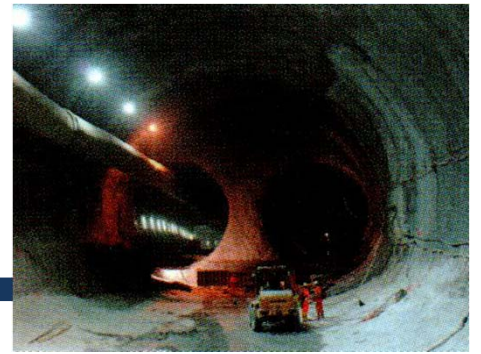

- 터널간의 상호 간격

- 2개 이상의 병렬로 터널을 계획하는 경우에는 터널의 단면 형상, 치수, 시공법, 시공 시기 등을 검토하여 상호 간격을 결정
- 일반 지반: 중심간격을 굴착 폭의 2배 정도
- 연약 지반: 중심간격을 굴착 폭의 5배 정도

- 터널 갱구부

- 갱구의 위치는 공사용 설비의 배치, 공사용 도로의 설치, 사토장, 공사용 전력의 확보와 장래의 유지관리 등을 고려하여 선정
- 갱구부는 경사면과 인접하고 토피가 얇아서 불안정한 곳이므로 갱문은 비탈면의 최대 경사각과 직교하거나 비탈면의 활동이 없는 안정한 지반에 설치
- 비탈면의 붕괴, 낙석, 토석류, 홍수, 눈, 안개 등의 불리한 위치에 갱구를 설치하는 경우에는 갱구부의 안정성 검토와 방재설비를 고려하여 위치선정

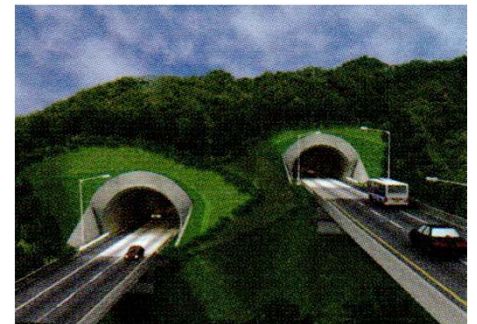

Tunnel Project Planning

• 터널의 단면

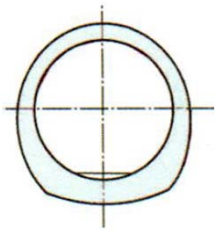

(a) 원형

구조적으로 안정하고
양수압에 대하여 유리
굴착면적이 커서
비경제적이고 굴착
시공이 어려움

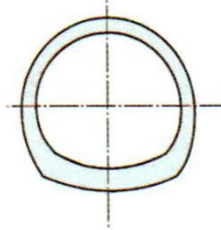

(b) 난형

구조적으로 안정하고
양수압에도 안정하며
원형보다 경제적
마제형보다 굴착량이 큼

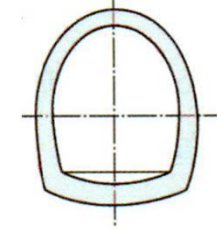

(c) 마제형

굴착 시공성이 양호,
여굴량이 적어서 경제적
구조적으로 불리,
양수압에도 불안정

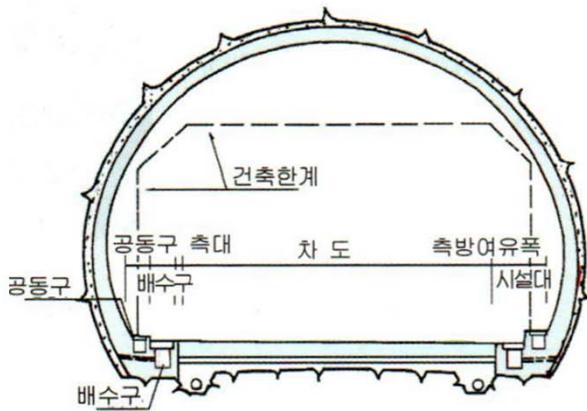

Maintenance access(검사원통로): consider the location of utility conduit and emergency access, 1m from road surface and min 0.75m width for safety, 2m pass height

Facility free zone(시설한계): obstacle free zone for traffic safety, larger than 4.8m

Road width: same to connected roads

Pipe utility conduit(공동구): conduit for electricity, fireplug, drainage pipe, etc.

Drainage: for gushout water, surface water, waste water

측방여유폭: road edge to free zone, same to road shoulder, min 1m for highway, if less than 2m for 1,000m or longer tunnel, need to equip with emergency parking space every 750m (emergency, accident vehicles)

Equipment space(시설대): for lighting, emergency equipment

Tunnel Project Planning

- Cross Section for Ventilation

Channeling: Install duct systems considering tunnel length, ventilation volume

Jet fan: 0.2m from the facility free zone, Normally hanging to the ceiling, hanging distance = 0.5 of the fan diameter

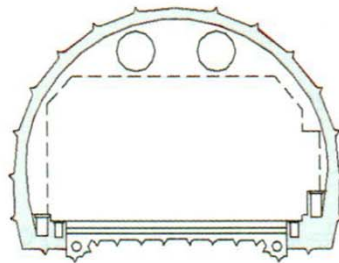

(a) 종류식(jet fan)

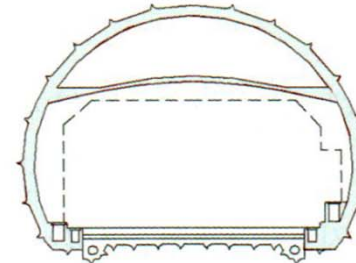

(b) 반횡류식

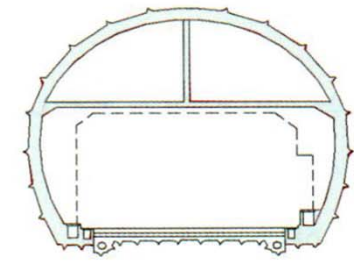

(c) 횡류식

- Emergency Access

- Emergency path(피난연결통로): (1) path connecting multiple tunnels or the tunnel and emergency tunnel, (2) doors should be smoke protected, fire protected, and non-powered, (3) set up every 250m, bigger one for emergency vehicles every 750m, every 300m for the tunnel less than 1,200m length
- Emergency tunnel(피난대피터널): (1) tunnel for evacuation (parallel, vertical) connected with emergency paths, (2) provide air, pressurized facility to protect smoke inflow
- Emergency shelter(피난대피소): (1) equipped with emergency lights, telephone, fireplug, CCTV, battery

Tunnel Excavation

- Excavation Equipment



Power Shovel

Widely used, Easy for loose earth, Slow for hard earth

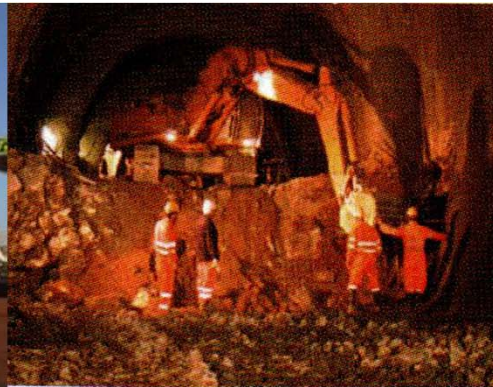

Power Breaker

Wide applicability, Slow speed, Noise and vibration

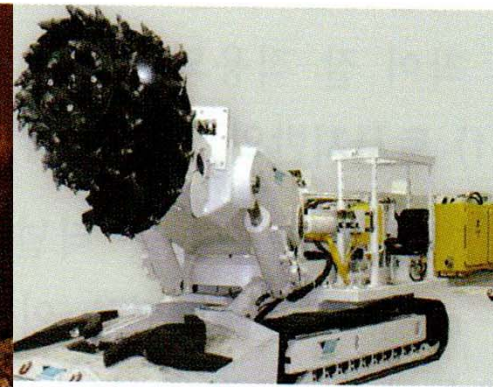

Road Header

Rotating cutter header, Mucking(버력) – reduce muck loading time, Many consumption of picks for hard earth, Lots of dust – require ventilation, sprinkling



Tunnel Boring Machine

TBM, Rotating and mucking, Open TBM for rocks (reaction to tunnel walls) and shield TBM for soil and weathered rocks (self-powered)

발파굴착: economical, easy construction, vibration, noise, performed with other equipment operations

파쇄굴착: (1) static: expansion by gas pressure → cracking → breaker/backhoe, (2) dynamic: frequent impact → surface expansion

Tunnel Excavation

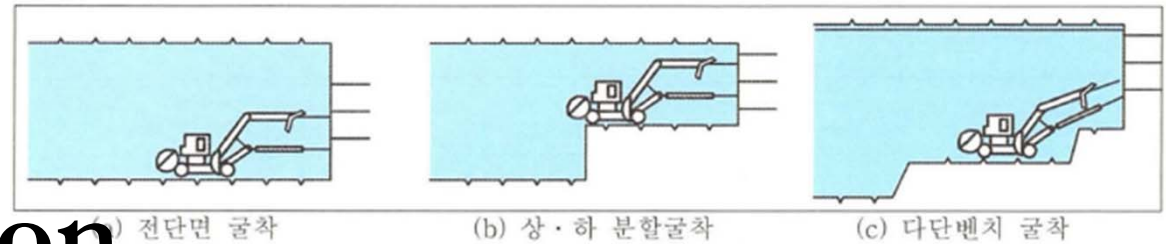

• Excavation Method

– Total Cross Section Excavation (전단면굴착)

- Hard earth condition (self-bearing)
- Small/medium-size cross sections
- Simple and fast operation with equipment
- Early stabilization(응력재배치 1-cycle 완료), clean tunnel face(막장)
- Difficult to earth risk management, delay on shortcreting/rockbolting, need big working platform



– Bench Cut (수평분할굴착)

- Large cross section
- **Long bench** (digging depth, 파들어가는 길이): $> 3D$ (or 50m), hard earth conditions
- **Short bench**: $1D$ (or 10m) $<$ bench $<$ $3D$, normal earth
- **Mini bench**: $< 1D$, soft earth
- **Multi bench**: 3 or more benches, unstable earth conditions

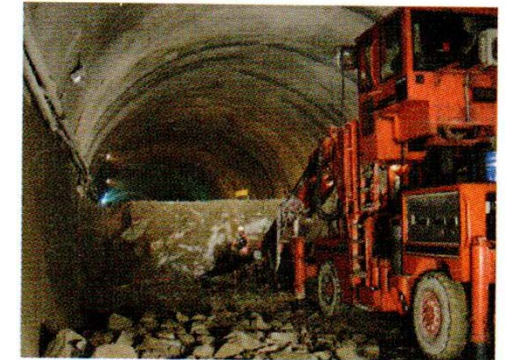

Tunnel Excavation

- Excavation Method

- Bench Cut (수평분할굴착)

- Temporary Invert** (가인버트): for medium/large cross sections, excavate long bench while temporarily shotcreting above the bench for deeper excavation (provide larger working areas), not economical considering shotcreting and curing time
 - Ring cut:** leave supporting 2-3m core to tunnel face pressure and excavate, soft/poor earth, reduced and limited working areas



굴착공법	개념도		
	횡단면	종단면	
전단면 굴착			
수평분할굴착	Long bench cut		
	Short bench cut		
	Mini-bench cut		
	Multi-bench cut		
	Ring-Cut굴착		

Tunnel Excavation

- Excavation Method

- Vertical Cut (중벽/연직분할굴착)

- When top earth condition is weak and the large cross section does not have bearing capacity, Temporary supports like rock bolts or shotcrete, 1D~2D

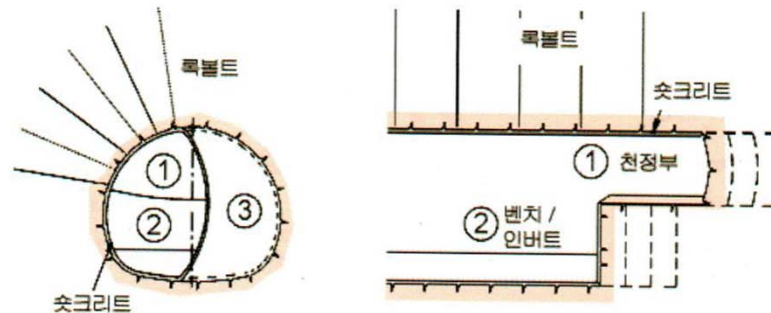

- Side Pilot Drifting (선진도갱굴착)

- For very large cross sections, excavate while checking earth and underground water conditions, Set early bearing capacity, Water drainage through side pilots

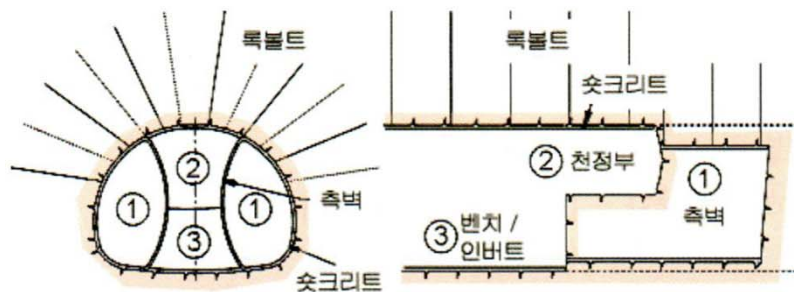

측벽도갱으로
굴착면을 미리
보강 → 터널안정
확보, 배수용이



Tunnel Excavation

- Excavation Method
 - Blasting

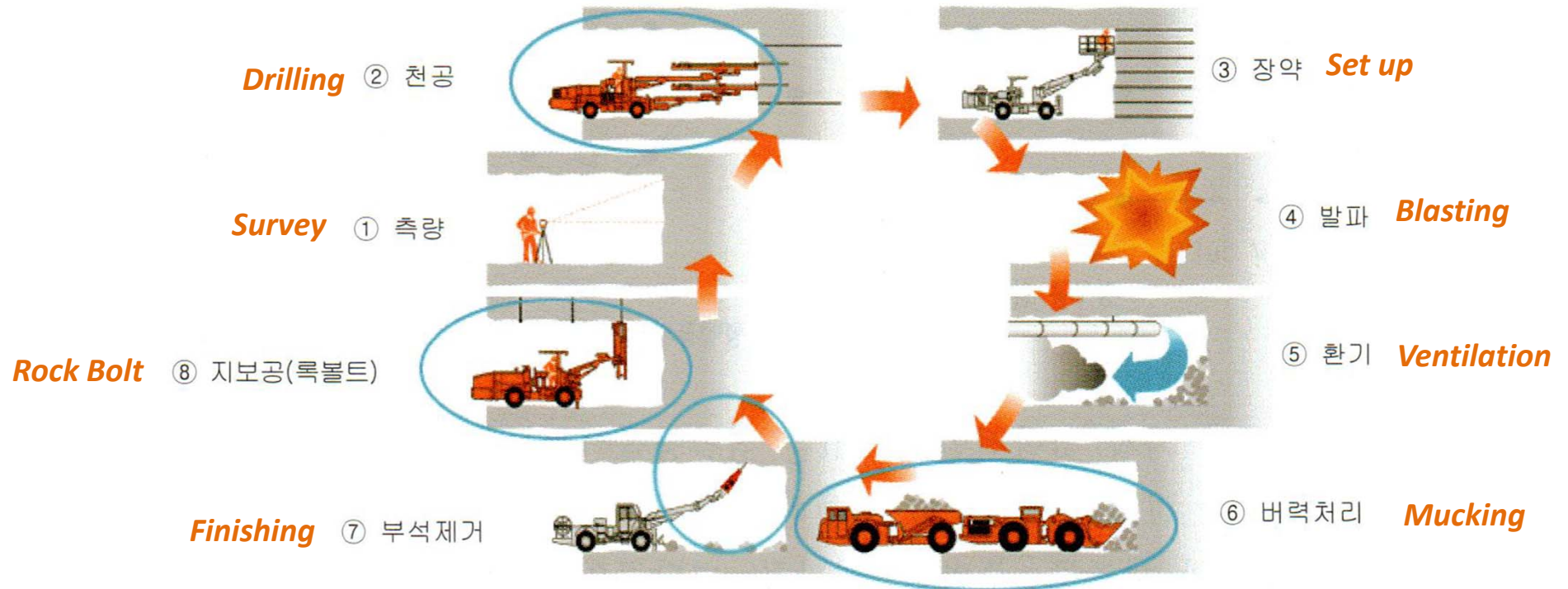

Tunnel Excavation

- Excavation Method
 - Blasting Method

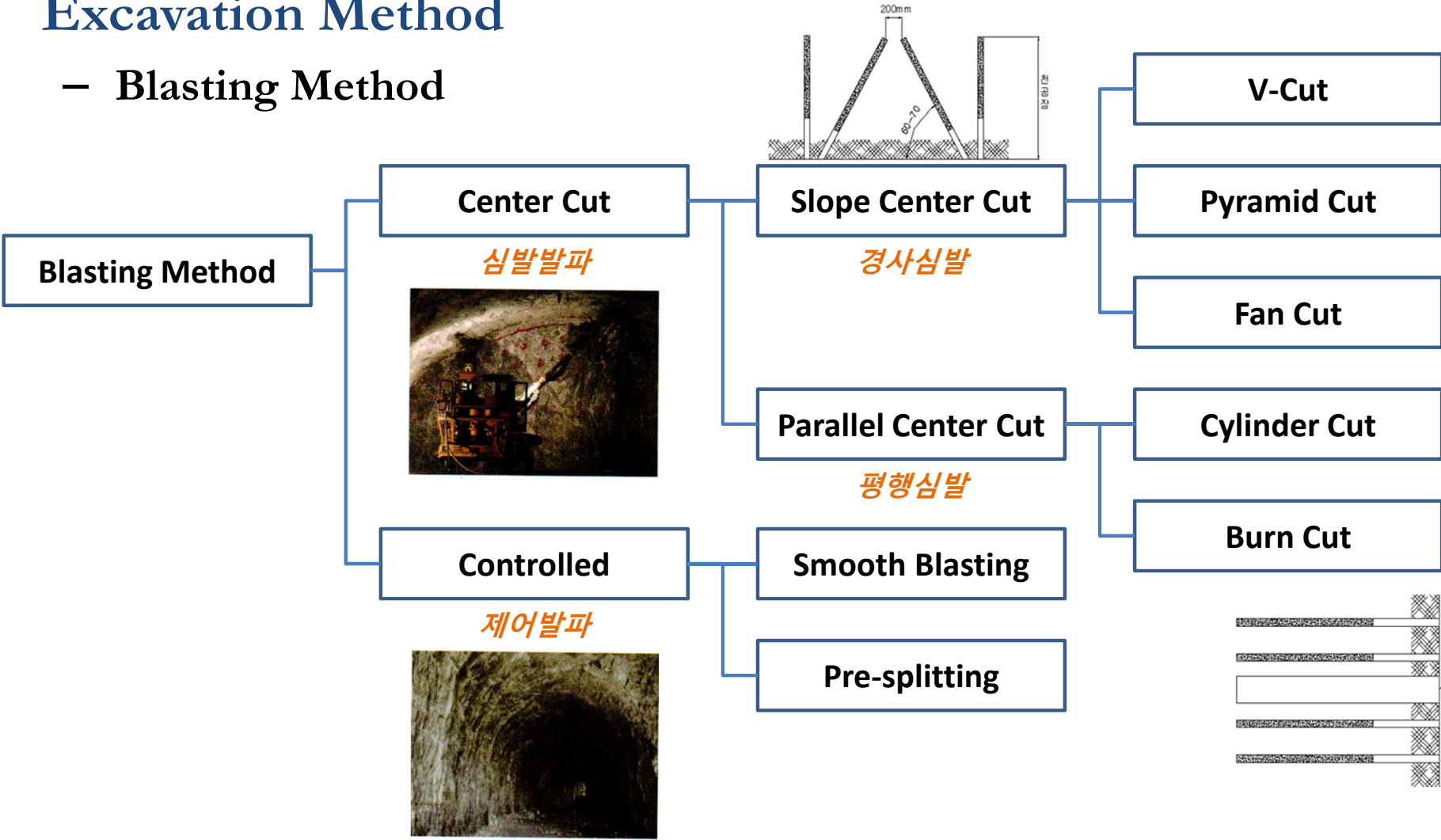

Drilling: Accurate drilling leads to accurate excavation, Should deliver correct blasting power to correct direction, Too much blasting requires additional supports, Laser point survey

Tunnel Excavation

• Excavation Method

– Blasting Method: V-Cut

- Most common method, easy set up
- Big muck size scattering less
- Noisy and large vibration
- Ideal to point to the center line to maximize blasting
- Good for large sections, but difficult for small sections

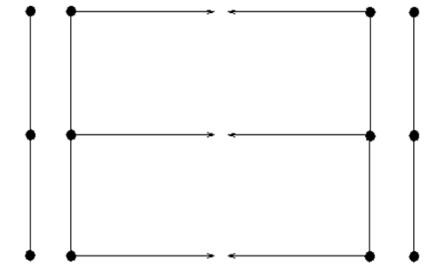
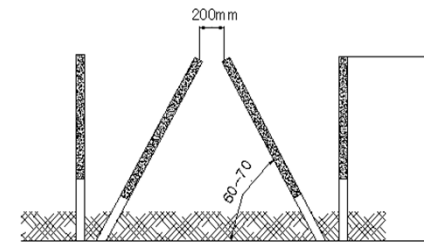
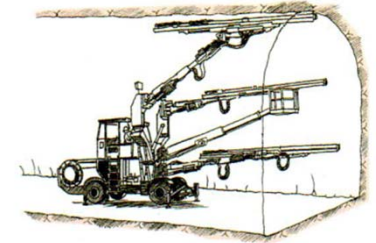
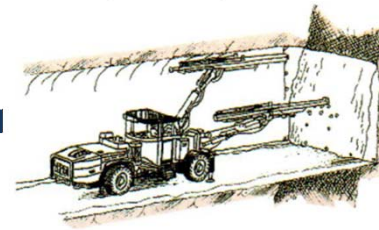

– Blasting Method: Burn/Cylinder Cut

- Drill burn hole (무장약공) at the center
- Burn cut (<75mm) < Cylinder cut (>200mm)
- Applicable to any size of the cross section
- Small vibration (accurate blasting, good for urban areas)
- Small muck scattering further, Noisy due to burn hole
- Long drilling time, require accurate drilling skills and equipment

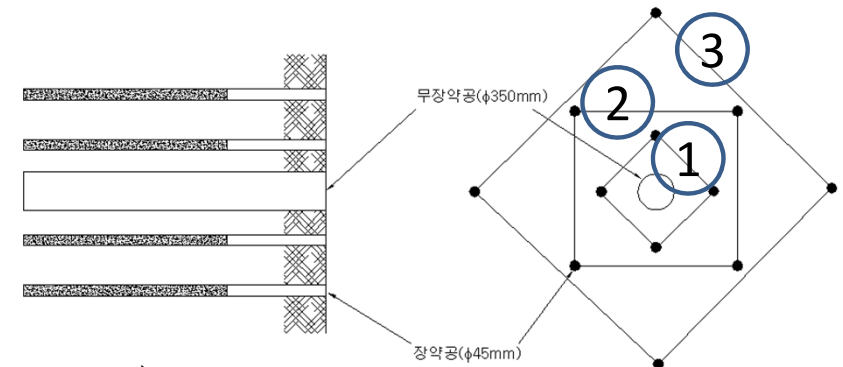

Tunnel Excavation

- **Excavation Method**

- **Blasting Method: Smooth Blasting (제어발파)**

- Difficult to expect and control blasting with common approaches → Possible cracks and overbreak(여굴)
 - Controlled blasting: very difficult, Accurate design of explosive amount and drilling intervals

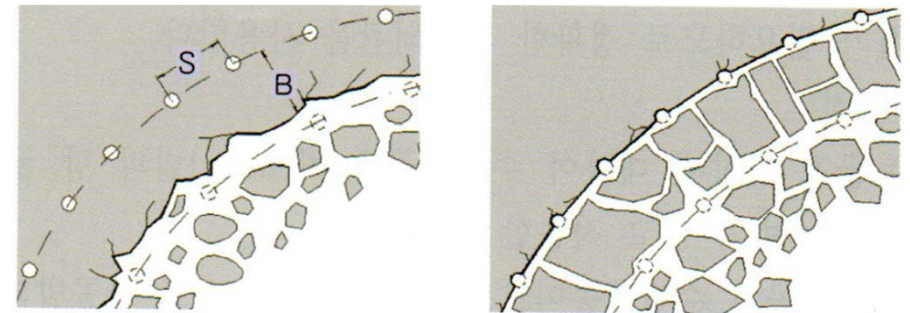
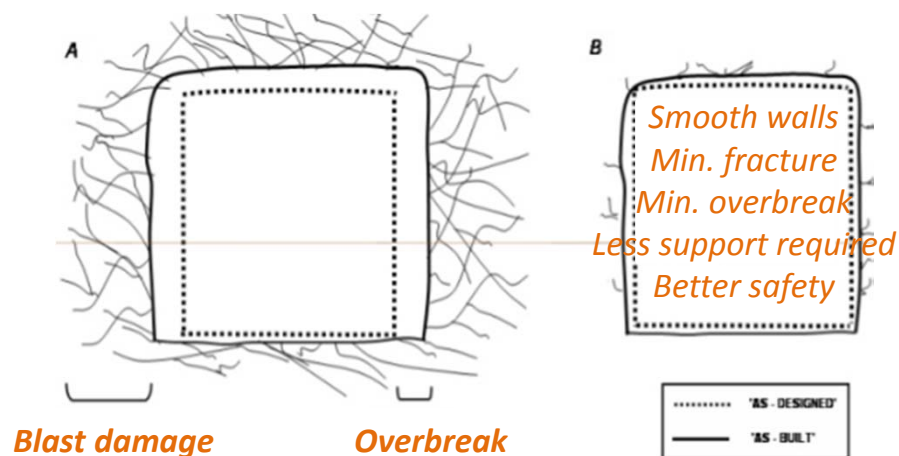

Contour holes act as a cushion to protect extra blasting by air voids and make smooth surface blasting by gas pressure (천공경보다 작은 지름의 폭약 사용)

***Pre-splitting:** blasting contour surface first then going to remaining parts*

Tunnel Excavation

- **Overbreak**

- Increase project cost (normally 15-20%) due to additional explosive, muck, shotcrete and rock bolt amounts, Impossible to eliminate, target to minimize
- Causes
 - Drilling equipment: Jumbo drill length 3.7m(about 26cm overbreak), 4.2m(29cm), 4.7m(39cm), Possible bending of the drill rod
 - Drilling position and skill: Affected by working complexity
 - Blasting method
 - Topological condition: Changeable earth condition during excavation
- Allowable standards: Arch section: 15-20cm, Wall section: 10-15cm

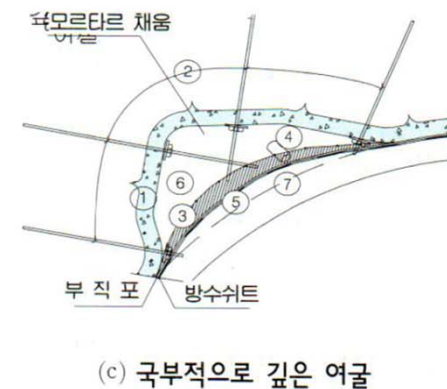
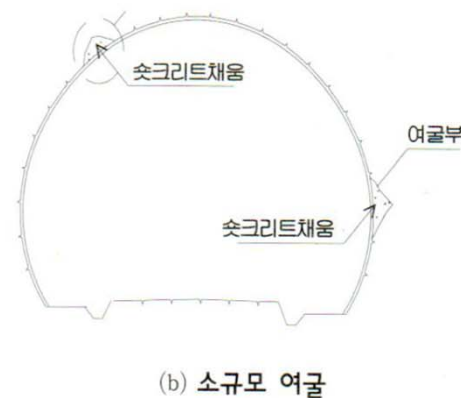
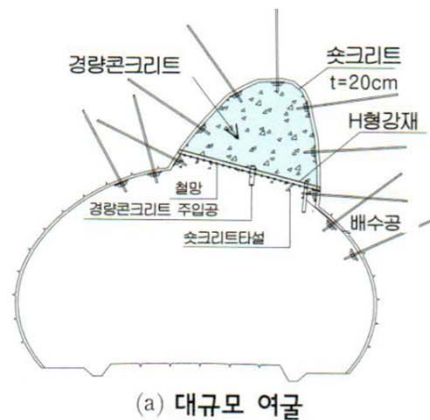

Tunnel Excavation

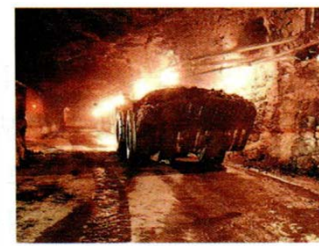

- **Mucking**

- Take 1/4 – 1/3 of total project duration
- Mucking volume = Excavation volume x (1+overbreak %) x changing factor

	Original Earth		Transportation	
	Volume	Unit Weight (kN/m ³)	Volume	Unit Weight (kN/m ³)
Normal Rock	1	22-28	1.4-1.8	14-20
Soft Rock	1	20-25	1.3-1.7	13-19
Soil	1	15-22	1.2-1.5	12-18

- Grade 12% or less for dump truck traveling
- Rail type transportation for small cross sections

Tunnel Support

Shotcrete Mixing

Portland cement, 0.1mm or less fine aggregates,
10mm or less clean and round coarse aggregates,
10MPa compressed strength for 1 day
(21MPa for 28 days),
5-10% accelerating agent



• Shotcrete

- Most important support (first) by spraying mortar or concrete
- Fast gain of strength, applicable to any cross section
- Requirement, (1) bearing capacity, (2) adhesiveness and durability, (3) high watertightness, (4) less rebound and dust, (5) waterproof and drainage



Compressed air
for delivery 압축공기

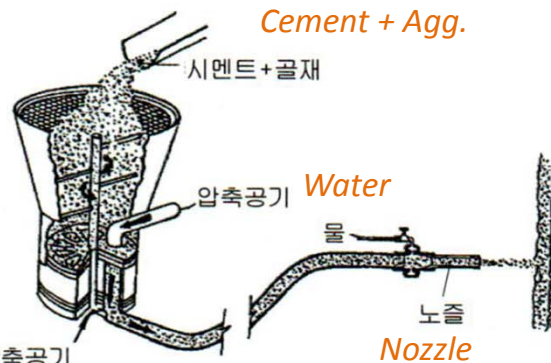

Dry-mix Process

Shotcrete quality depending on worker skills
Small-size project
Long distance delivery (200m)
Poor working condition: large dust and scattering
Large rebound (30-50%)
Small and maintainable equipment

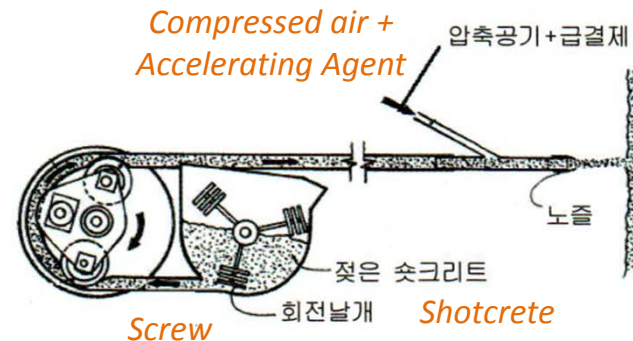

Wet-mix Process

Good shotcrete quality control
Large-size project
Shorter delivery (80m)
Better working condition
Less rebound (10-20%)
Large equipment, difficult maintenance (막힘)

Tunnel Support

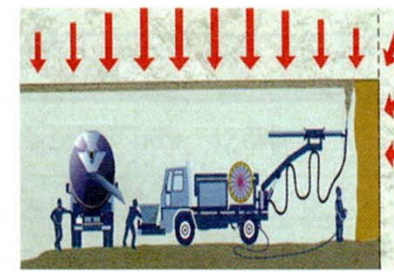
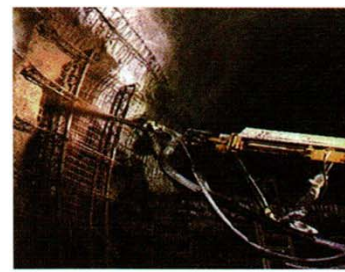

- Shotcrete 두께

단면크기	Normal/Hard Rock	Soft Rock	Weathered Rock	Soil
30 m ² or less	5cm	5-10cm	5-10cm	10-15cm
30-40m ²	5-10	10-15	15-20	about 20cm
40-80m ²	5-10	10-15	15-20	20-25cm
80-120m ²	5-10	10-20	15-20	about 25cm

For very stable and hardened earth, possible less than 5cm

If too weak, avoid too thick shotcreting and consider to use rebar or steel fiber with shotcreting

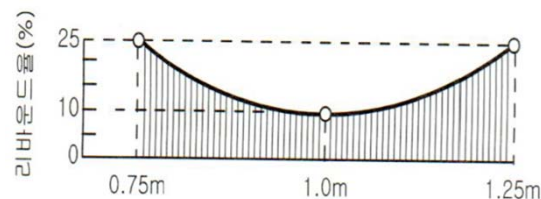

Excavation → Finishing(먼지, 부석 등에 의한 타설 후 박리 방지) → 즉시, Shotcreting 1m from the surface, vertical to surface, wall to arch(탈락한 슛크리트는 바닥면에 쌓임), 10cm or less at one time and repeat (박리방지)

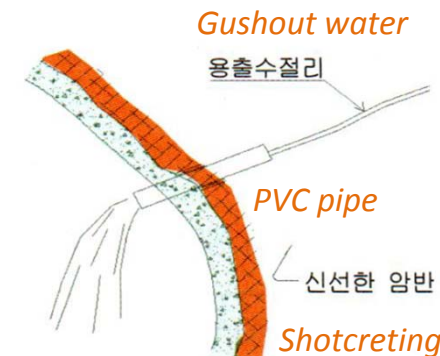

용수에 의한 슛크리트 탈락 방지 → 배수파이프 설치 후 타설 소량의 용수: 마른 상태의 슛크리트를 용수와 혼합시킨 후 타설

Tunnel Support

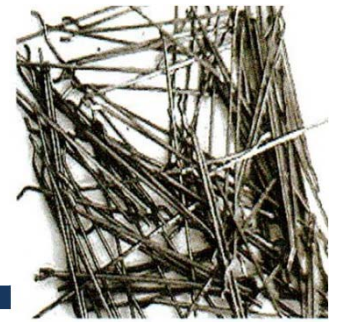

- **Steel Fiber Reinforced Shotcrete (SFERS, 섬유보강 슛크리트)**
 - Steel fiber, glass fiber, plastic fiber
 - Steel fiber: 700MPa or over tensile strength, 0.3-0.6mm diameter, 30-40mm length
 - Early reaching good bearing strength for loading, bending stress, and impact
 - Less void in shotcrete, used for wet-mix only



Wire Mesh + Shotcrete (철망을 설치하고 슛크리트 타설)

Difficult to install if large overbreak

Less adhesiveness and layer separation with vibration to the mesh during shotcreting

Decreased supporting effect considering the time for mesh installation



SFERS (스틉크리트의 인장강도를 보완하기 위해 강섬유를 혼입)

Uniform thick placement of shotcrete

Good bearing capacity with reduced thickness of shotcrete

Prompt placement and support right after excavation

Simple operation and good quality

Tunnel Support

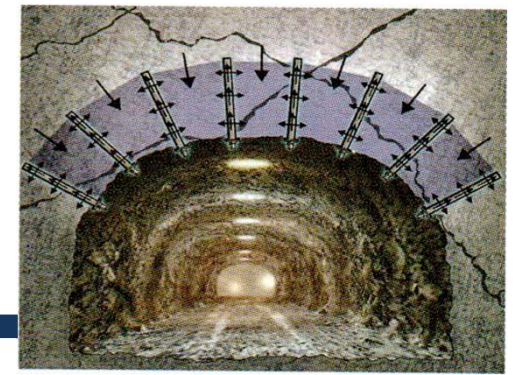

- Rock Bolt

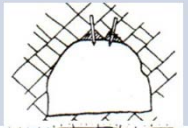
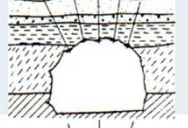
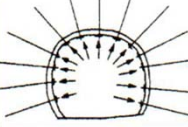
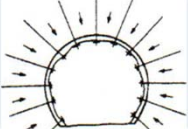
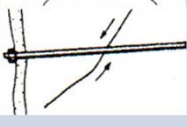
Function	Effect	Concept
봉합 또는 매달음 작용	이완된 암괴를 원지반에 고정하여 낙하를 방지하며 균열이나 절리가 발달된 지반에서 슛크리트와 병용하면 작은 균열에도 효과적	
보형성 작용	층상으로 절리가 발달된 지반에서 록볼트로 절리면 사이를 조여서 전단력을 전달하여 합성보로 거동	
내압 작용	록볼트의 인장력에 의하여 터널 벽면 내압이 발생하여 터널 주변지반을 잡아줌	
아치형성 작용	시스템 록볼트에 의해 내하능력이 커진 굴착면 주변의 지반이 내공측으로 일정하게 변형하여 내하력이 큰 아치가 형성	
지반보강 작용	록볼트를 타설하면 지반의 전단저항력이 증대하여 지반 내하력과 항복후의 잔류강도가 증가	

Head bolting (선단정착형), Whole surface bolting (전면접착식), Combination (혼합식), Friction bolt (마찰형)

Tunnel Support

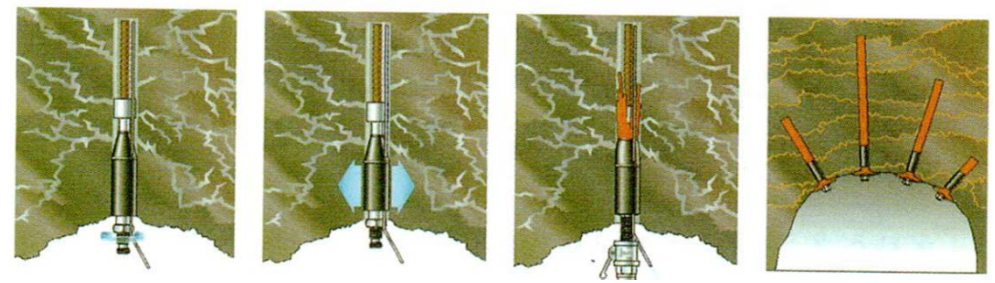

- **Rock Bolt Type**

- **선단정착형** (선단을 암반에 정착)
 - By equipment: wedge type, expansion type
 - By capsule: resin type
 - Good for ground sealing, normal/soft rocks

- **전면접착형** (전체길이를 암반에 정착)
 - Fix total rock bolt to the earth with filler(충진재)
 - Soft/weathered rocks
- **혼합형**
 - Head bolting + Cement grouting

Resin Type

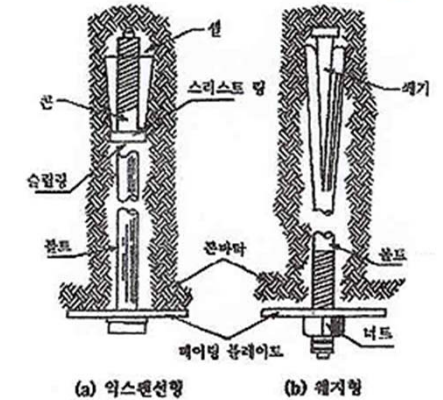

(a) 익스팬션형 (b) 쐩지형

Expansion Wedge

- **마찰형**

- Whole surface bolting starts bearing once the filler is hardened, the friction bolt immediately supports once placement (수압으로 볼트를 팽창)

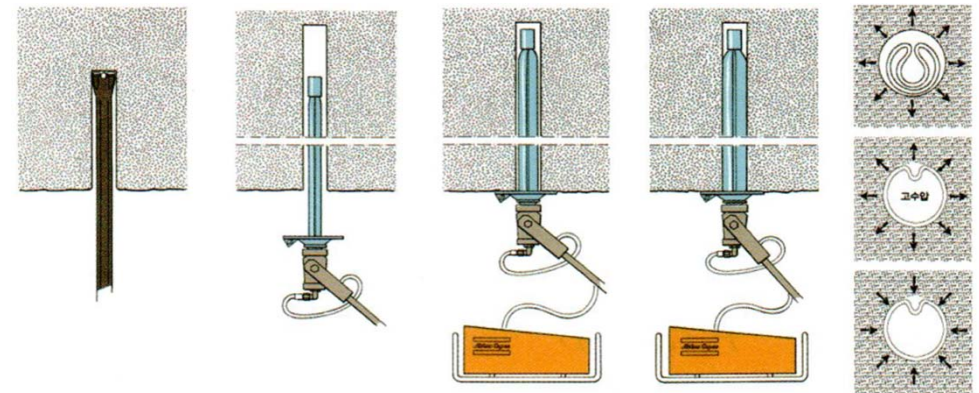
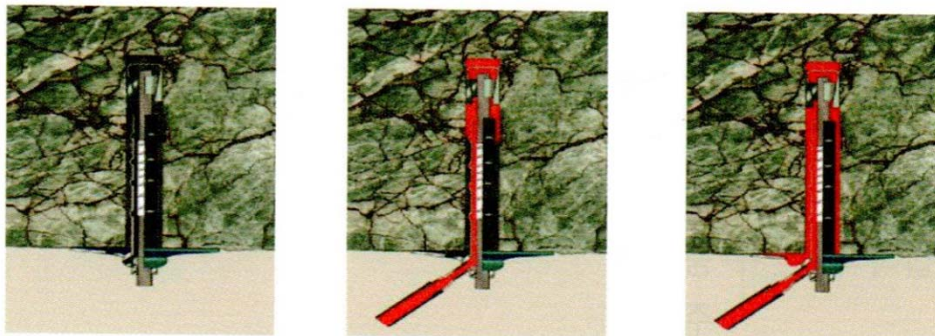

Tunnel Support

- Rock Bolt

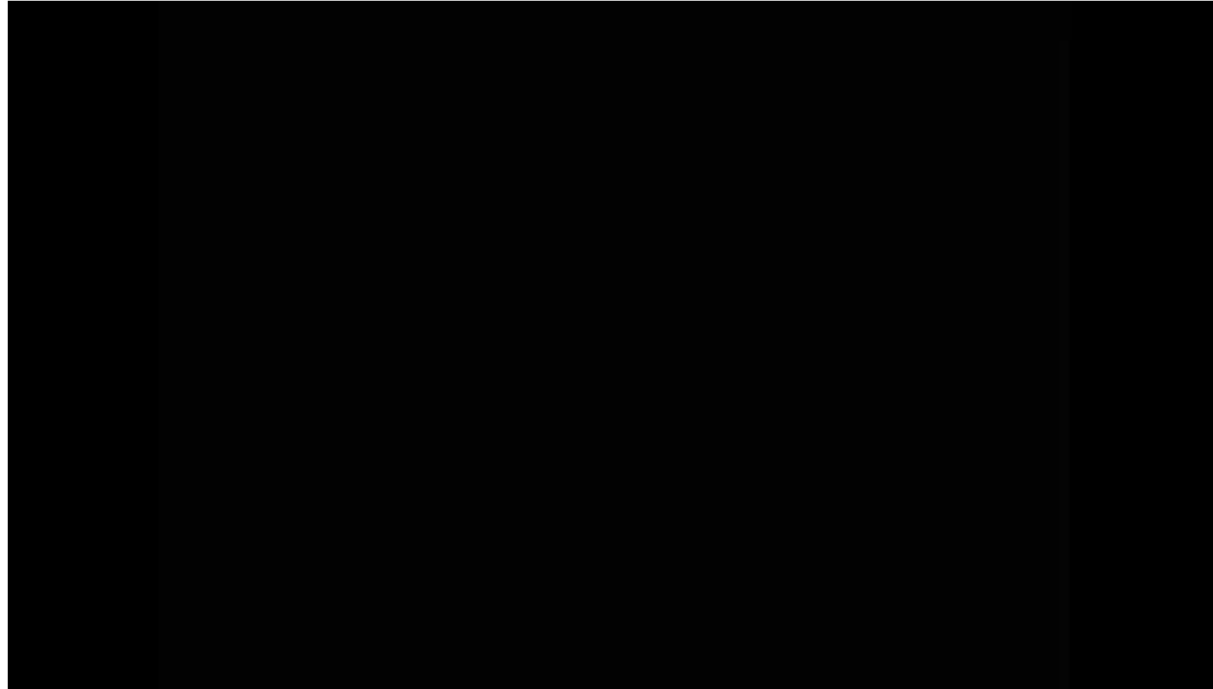

Tunnel Support

- Rock Bolt

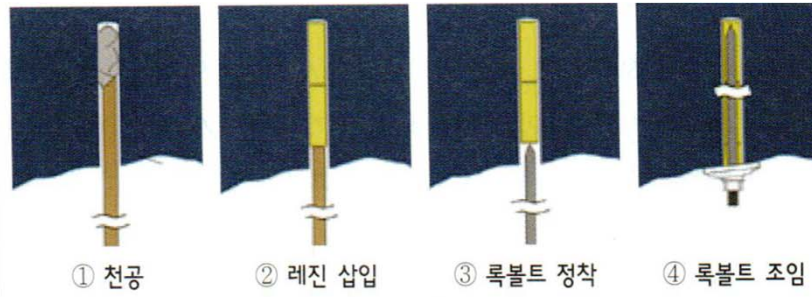
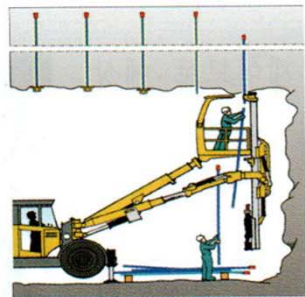

Instant installation when earth pressure is big
If not (for hardened earth), install every 2-3 cycles

Resin Type

Drilling: (1) if the hole is too small, difficult to insert bolt and adhesive; if the hole is too big, difficult to reach enough settlement; (2) Drill little bit deeper than the rock bolt length for expansion type, shorter for wedge and resin types (지압판 부착을 위해서)

Earth Type	Function	Installation	Concept
연암 - 중경암	봉합효과	암괴를 봉합하여 붕락 방지 아치부에 배치	
풍화암 - 연암	내압 및 아치형성	시스템 록볼트로 내압 및 보 형성 효과를 기대, 터널 아치부와 측벽부에 배치, 팽창성 지반은 인버트에도 배치	
토사	전단저항	연약한 지반의 터널 측벽부에 발생하는 전단파괴를 방지하도록 배치, 아치 천단부를 제외한 아치 및 측벽부에 배치	

Tunnel Support

- **Rock Bolt**

- **Anchor Plate (지압판)**

- Unification of rock bolt and shotcrete
 - Normally 150x150mm with 6mm thickness (9mm for expandable earth)
 - If vertical rock bolting is difficult, use a circular anchor plate

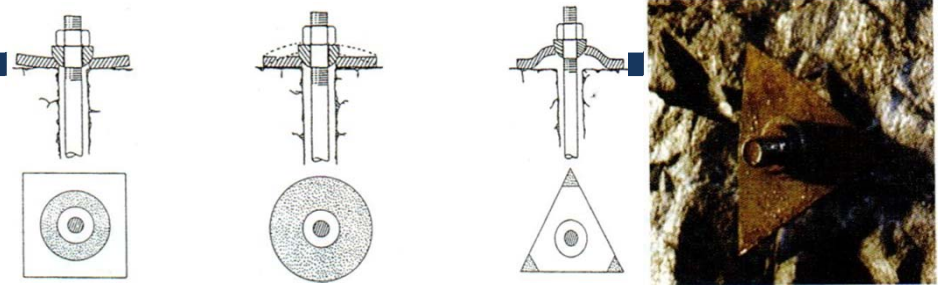

Self Drilling Rock Bolt (자천공 록볼트)

When difficult to maintain holes after drilling especially for very weak earth, drill by 2-5m rock bolt with bit and do grouting

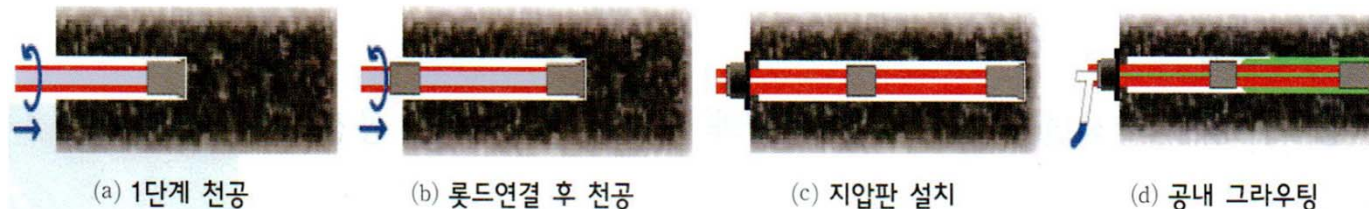

Tunnel Support

- **Steel Support**

- Directly support earth until the shotcrete reach the required bearing capacity, distribute loads to shotcrete, and shape the tunnel cross section

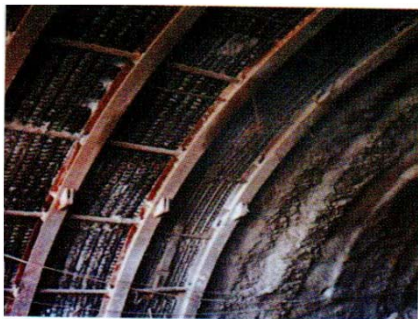
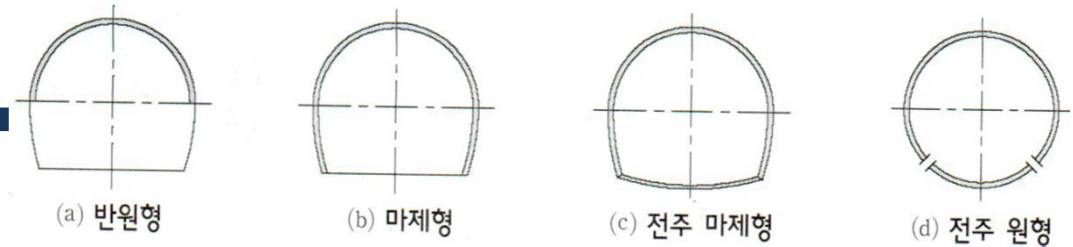

H-type steel support (H형 강지보재)

Good strength and bearing capacity usually used for weathered or soil earth

Heavy

Possible voids between earth surface and the steel support where shotcrete is difficult to reach

If the thickness of shotcrete is thin structural integrity b/w them becomes poor



Lattice Girder (격자지보재)

Triangular or rectangular steel structure

Lighter than other supports → easy to deliver and install

Forepoling can be placed through lattice spaces → high construction efficiency

Less strength than H-type

Very good adhesiveness with shotcrete, less rebound of shotcrete, good quality control

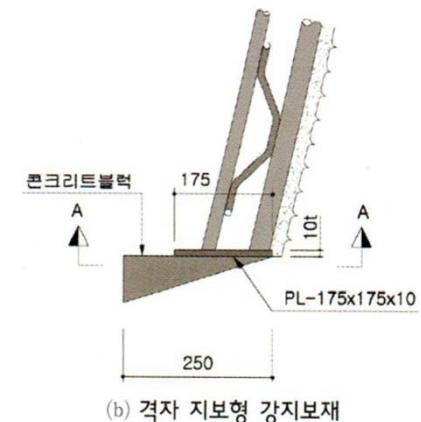
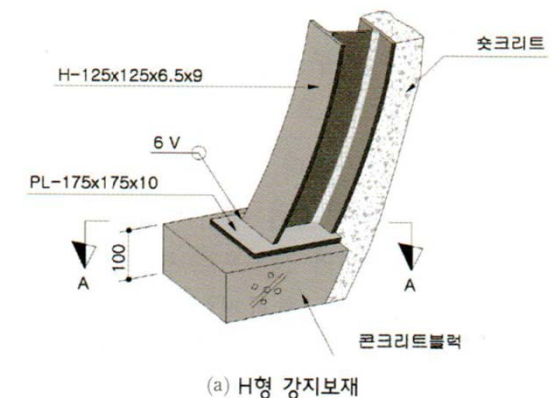

“For weak earth, install wood, concrete, or steel baseplate and supporting concrete”

Additional Supports

- 굴착보조공법

- Thin earth surface and weakened earth
- Preventing any possible deflection that affects adjacent structures
- The earth having a large amount of gushout water

Purpose		Method	Earth		
			Normal	Soft	Soil
지반강화 및 구조적 보강	천단안정	Pipe Roof (파이프루프)		△	△
		Sloping Rock Bolt (경사록볼트)		△	
		Forepoling (휘폴링)		△	△
		Reinforced Protective Umbrella (대구경 강관 다단그라우팅)		△	○
		Liquid Injection (약액주입)			○
	막장면/바닥면 안정	Tunnel Face Shotcrete (막장면 슛크리트)		△	○
		Tunnel Face Rock Bolt (막장면 록볼트)		△	△
		Ring Cut (코어핵)		△	△
	Temporary Invert (가인버트)		△	△	
용수대책	지수/배수	Liquid Injection (약액주입)	△	○	○
		De-watering (물빼기공)	△	○	○
		Well Point (웰포인트)			○
		Deep Well (딥웰)			○

Additional Supports

- Top Surface Stabilization

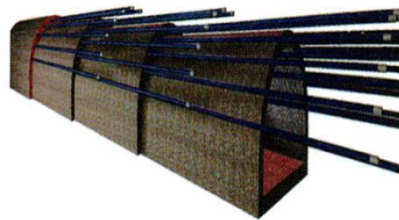

Forepoling(굴착 전 터널 천단부에 종방향으로 철근이나 강관을 설치)
 Strengthen/tighten top and top front surface and prevent spalling and falling
 D25 supporting rebar or 30-40mm steel pipe in 2-3 times length of excavated earth length
 Every 0.3-0.8m (횡방향), every 막장 (종방향)
 From the top point 30-60 degree to left and right sides
 To prevent overbreak drill less than 15 degree and mortar grouting after placement

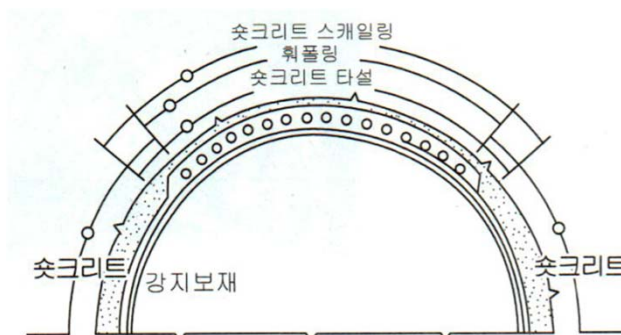
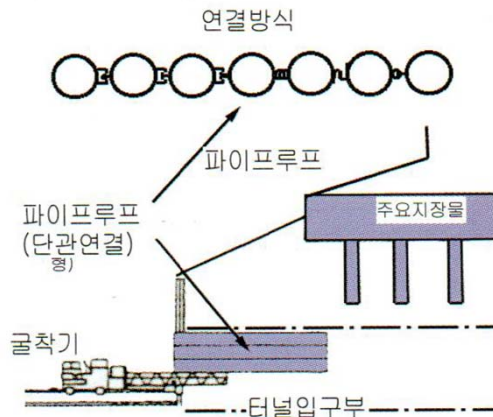

Pipe Roof

When the tunnel passes under the adjacent structure, support weak top earth
 Expensive and require spaces for working platform and various installation equipment
 6-15m length, 3-4mm thickness, 50-300mm diameter, every 2-2.5 times than diameter
 Horizontally (less than 5 degree) install



Additional Supports



- **Top Surface Stabilization**



R.P.U.M (Reinforced Protective Umbrella Method, 대구경 강관 다단 그라우팅)
Place long umbrella-shape tubes (steel pipe or Fiber Reinforced Pipe) to the tunnel front areas and insert grouting
Soil, weathered, or broken earth, minehead, and thin earth

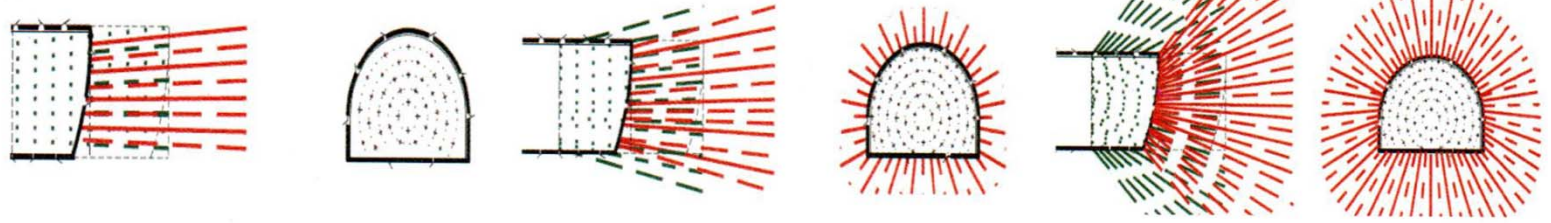

(a) Core의 보강

(b) 터널 반경방향의 보강

(c) 반경 및 길이방향의 보강

- **Tunnel Face Stabilization**

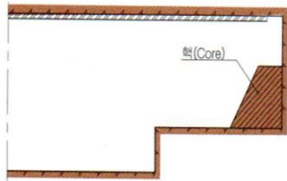

Ring Cut

Leave 2-3m core at the tunnel face to resist to pressure

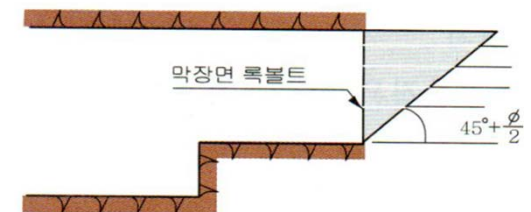
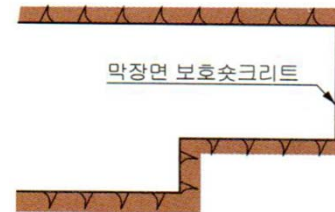

Tunnel Face Shotcrete or Rock Bolting

For protecting possible collapse within one cycle of operation

Concrete Lining

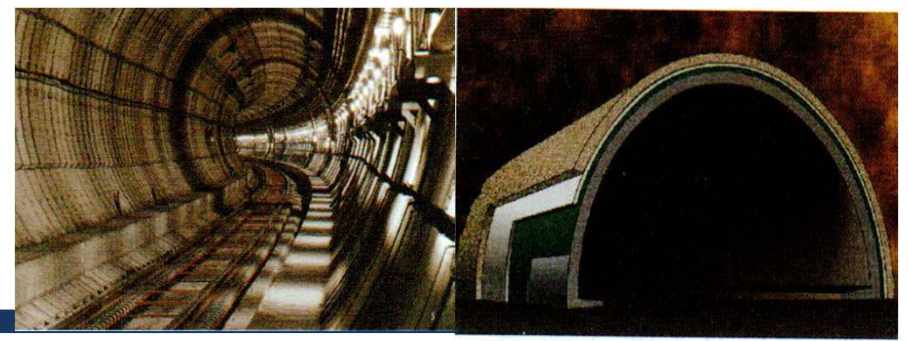

- **Function**

- Structurally stable: Should bear long-time earth pressure without cracks, deformation and collapse and enough durable to resist to settlement
- Less leakage and good watertightness
- Maintain convenience for ventilation, lightening, and other O&M

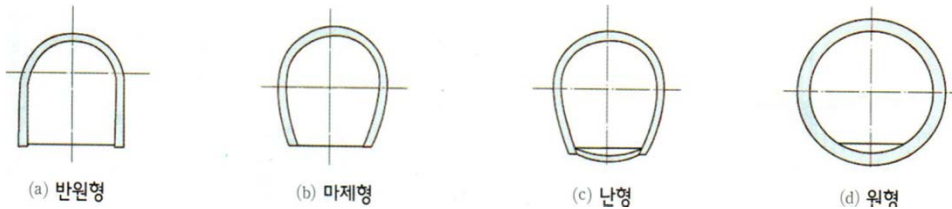

More unstable earth and earth pressure → more circular shape

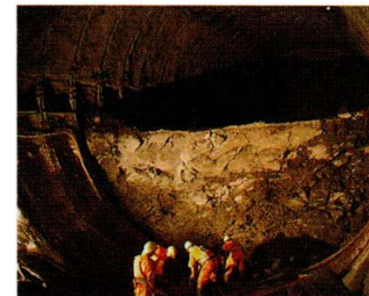

Invert

When uneven earth pressure is expected or for poor earth conditions, install inverts immediately as connection to side walls for better bearing capacity

Less deflection of tunnel structure

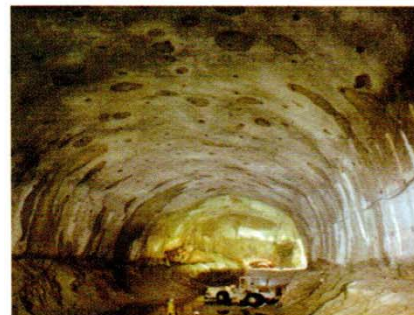

(a) Invert 굴착



(b) 인버트 굴착 후 strut 설치

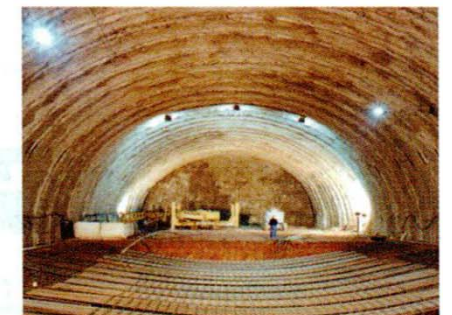

(c) 인버트 콘크리트 타설

Concrete Lining

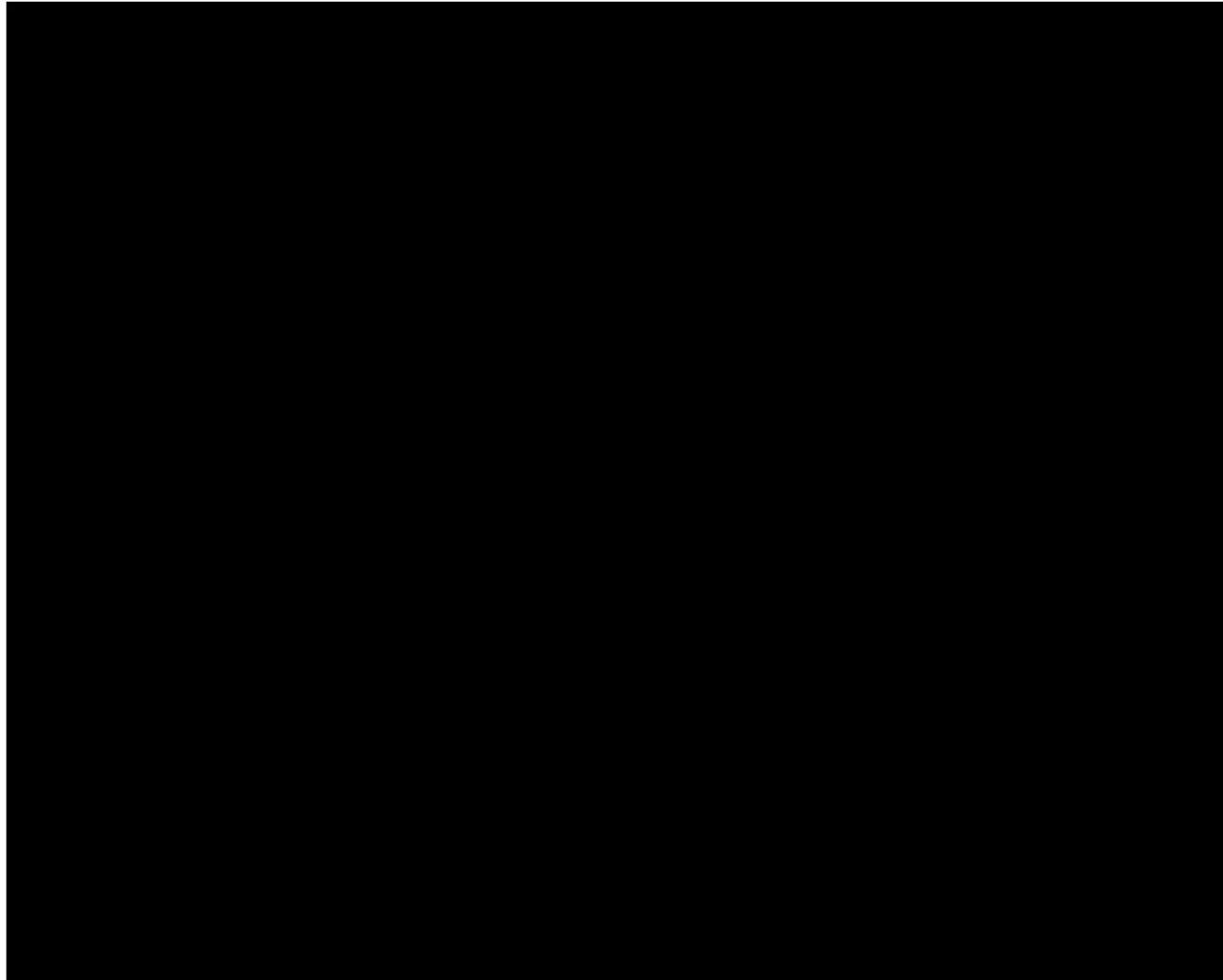

Concrete Lining

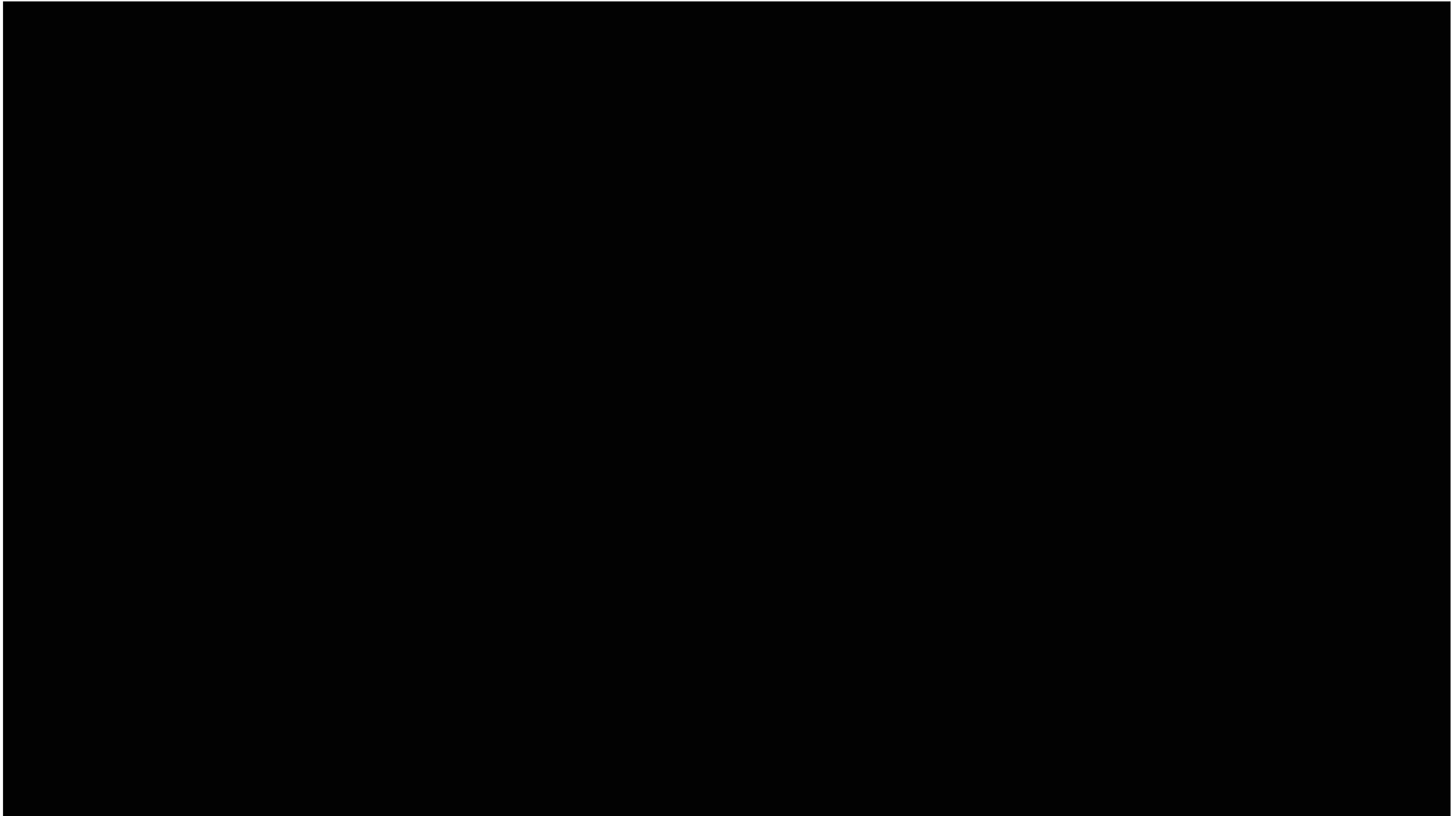

Concrete Lining

- Place after all tunnel structure is settled without further deformation or settlement and waterproofing/drainage is finished.
- Portland cement with AE agent and high-range water reducing agent
- 12-18cm slump, 21MPa designed strength, 20-40cm thickness for less bending moment



그림. 방수슈트와 라이닝 콘크리트 거푸집 설치

- **Forms (조립식, 이동식)**

- Normally use a whole section movable form (nontelescopic form), 9-12m form length

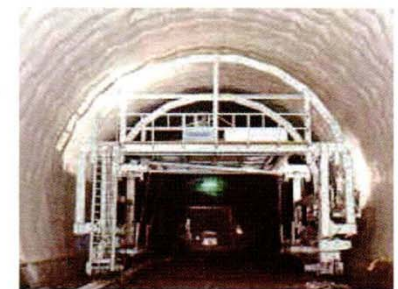
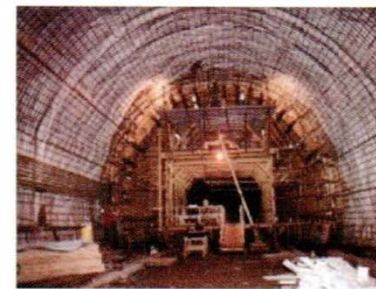
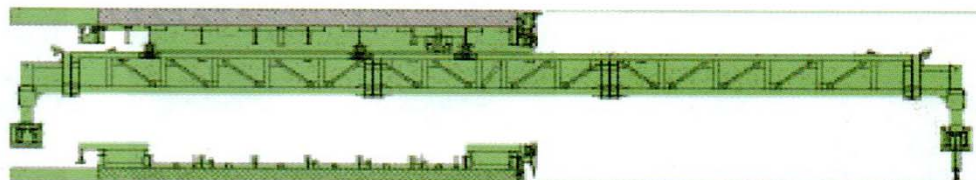
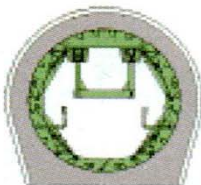

(b) 터널 외부 조립



(c) 터널내 조립

Concrete Lining



- **Lining Cracking**

- Reduce strength and watertightness that cause leakage, icecele, or freezing
- Special monitoring for areas having a large amount of gushout waters and short tunnels/갱구부 where can be easily affected by outside weather
- Crack more due to drying and shrinkage than increased tensioning

Cause (1) Concrete Materials

Cement abnormal expansion/freezing
 Concrete settlement/bleeding
 Cement hydration heat
 Aggregates quality
 Concrete stiffening/drying shrinkage

Cause (2) Loading

Actual loading over designed loading
 Earthquake
 Lack of cross sections and rebar
 Earth differential settlement

Cause (2) Construction Process

Too long concrete mixing
 W/C ratio changes during pumping
 Wrong concrete placement
 Too fast curing and lack of compaction
 Moved rebar positions
 Non-tight connection b/w parts
 Deformation of forms and supports
 Leakage
 Form earth removal
 Vibration and loading before stiffening
 Rapid drying during curing

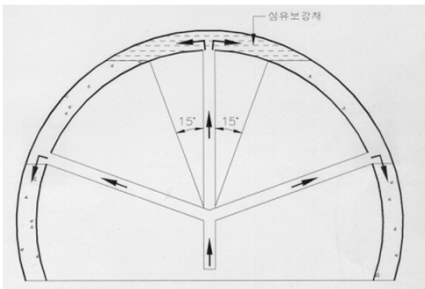

Fiber Reinforced Concrete

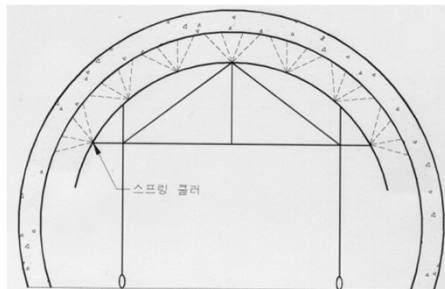

Wet Curing with Sprinkler

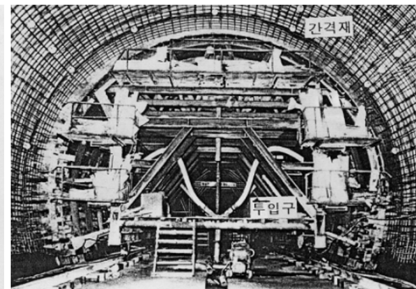

Use of Spacer

갱구부 및 터널 중간 계곡부의 개착부분, 터널과 터널 사이의 길이가 짧을 경우에 터널로 연장시키고자 할 때

Open Cut Tunnel (개착터널)

- Excavation → Tunnel Construction → Refilling

Open Cut through Precase Concrete Assembly

Foundation + Prefabrication (반아치형 세그먼트) simultaneous construction

→ Fast

Good quality, light, durable → less cracking, good watertightness and efficient maintenance

Thin thickness of the segment → economical, easy transportation and construction

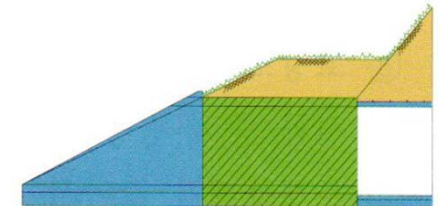

돌출형 갭문의 개착터널



(a) PC부재의 현장 운반

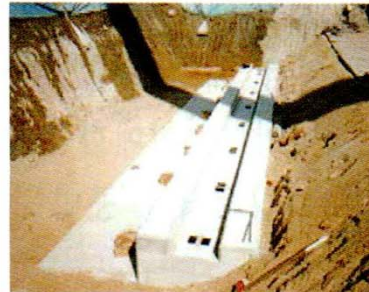

(b) 기초부 시공



(c) 아치형 세그먼트 조립

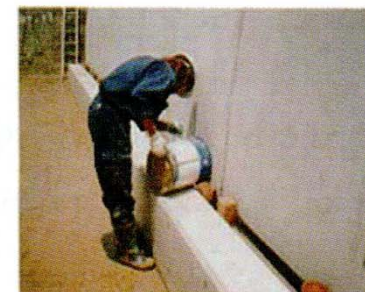

(d) 하단기초 모르타르 채움

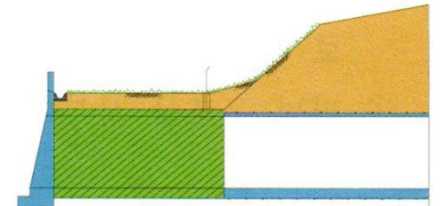

면벽형 갭문의 개착터널



(e) 연결부 방수처리



(f) 뒤채움 다짐



(g) Crown beam 거치/ 방수처리

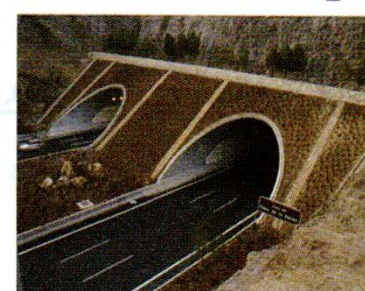

(h) 조립식 터널 시공 완료

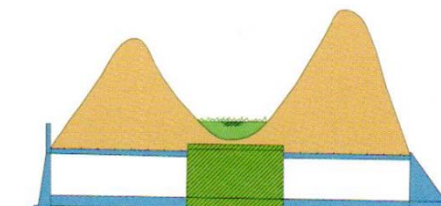

계곡 통과 시 개착터널

Immersed Tunnel (침매터널)



Immersed Tunnel

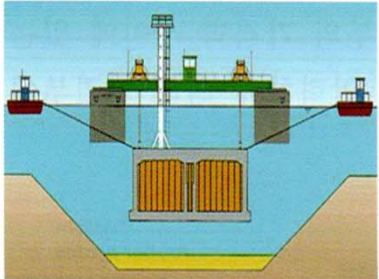

(a) 트랜치 굴착+침매함체 침설+접합

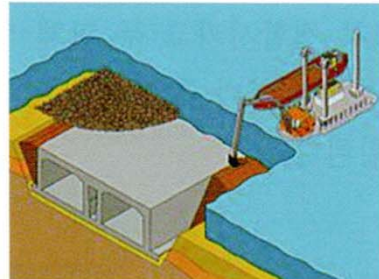

(b) 침매함체의 되메우기

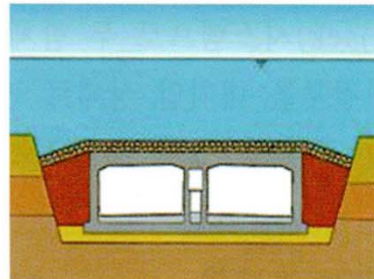

(c) 침매함체의 보호공

Transport prefabricated immersed tunnel segments and sink them by filling waters into the ballast tank in the segments

“Joint” is the most important part to determine life and performance of the tunnel, allow very limited movement

Rectangle: better space use, thicker cross section due to larger bending moment

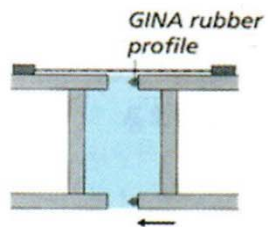
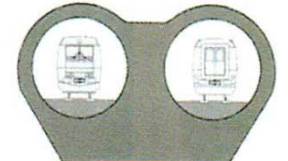
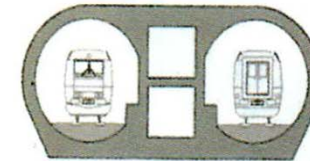
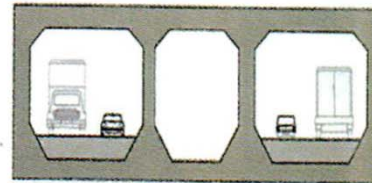
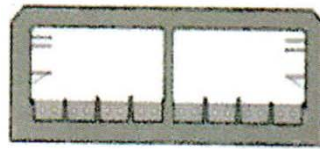

(a) 함체의 1차접합

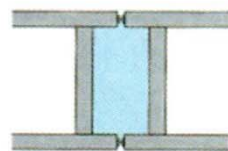

(b) 함체연결부의 배수

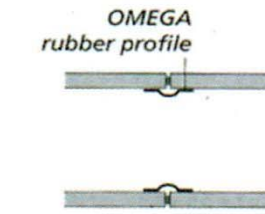
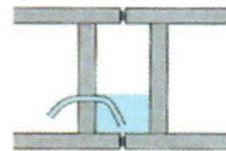

(c) 고무 침설조인트 접합



Immersion Joint: 침설 조인트는 침설된 선행함체와 연결되는 부분의 접합을 위한 조인트로서 고무재질로 제작되어 침매함체의 양단에 설치. 풀링잭 시스템으로 두 함체를 1차 접합시키고 두 함체 연결부의 가격벽 사이에 있는 물을 배제시켜서 연결부를 대기압 상태로 만들면 연결부와 침설함체 양단의 압력차에 의해 연결부에 기 설치된 고무 침설 조인트가 2차 수압으로 접합

Segment Joint: connect segments with rubber waterstops

Immersed Tunnel



(a) 침매함체의 제작



(b) Trench 굴착



(c) 침매함체의 진수



(d) 침매함체의 인양 및 이동



(e) 침매함체의 침설 거치



(f) 침매함체 주변의 되메우기

Gravel bed → Sink tunnel → Locking fill to prevent movement → Backfill and rock protection → Internal finish

DCM/SCP 등
기초보강 중요

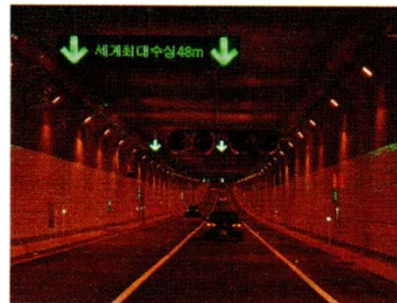

**거가대교: Busan-Gerjae Do 8.2km,
48m depth Immersed tunnel**

TBM (Tunnel Boring Machine)

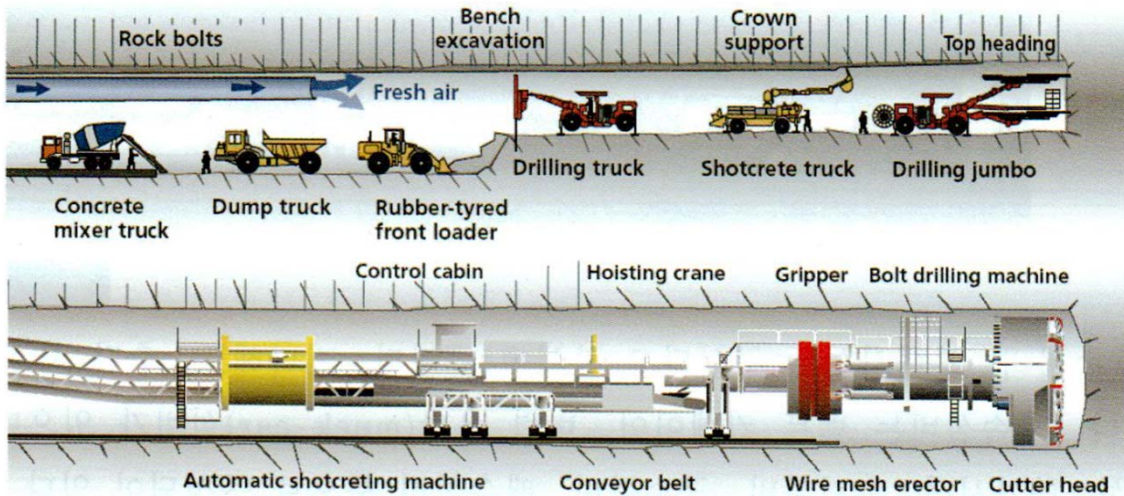

*Manual → Big Tunneling Machinery
Better safety, Reduce blasting pollution, Less
public complaint*

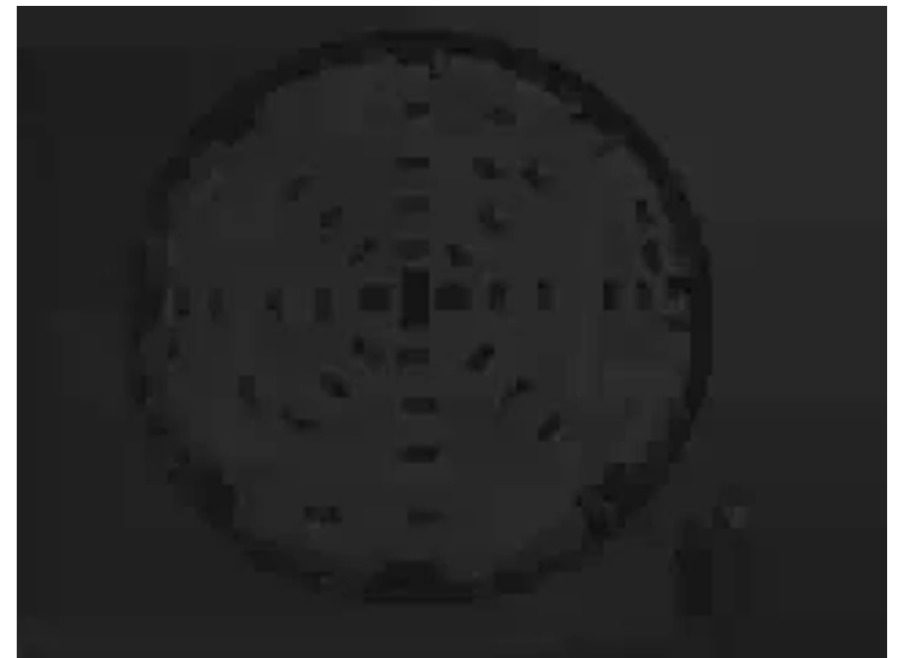

Open TBM

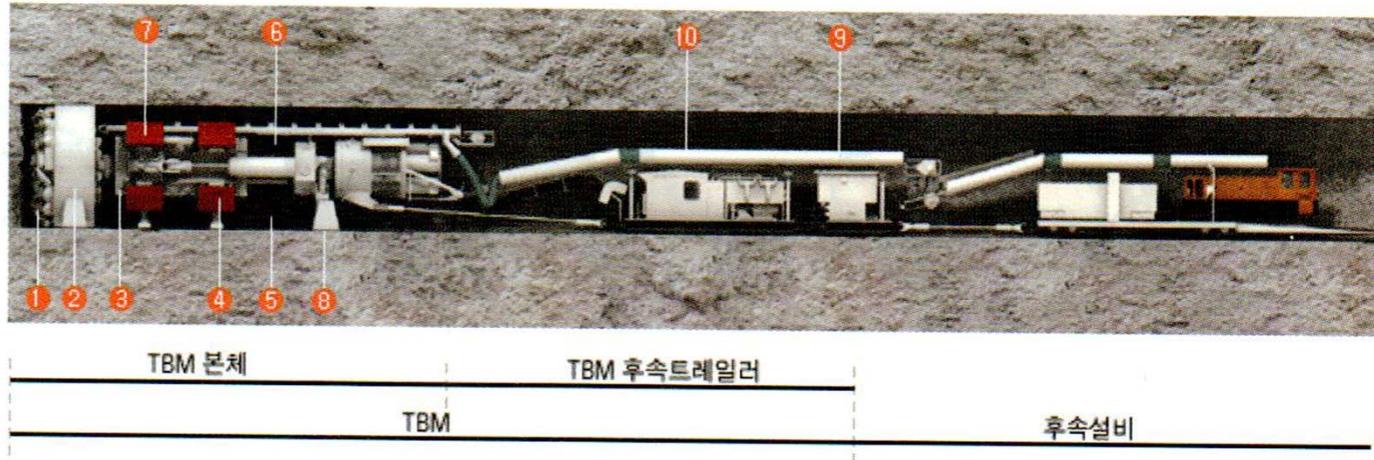

- ① Cutter Head ② Cutter Head Jacket ③ Inner Kelly ④ Outer Kelly ⑤ Advance Cylinder ⑥ Cutter Head Drive ⑦ Clamping Pad
- ⑧ Rear Support ⑨ Belt Conveyor ⑩ Dust Collector

Cutter Head: 커터의 압축력과 회전력에 의해 암석을 압쇄시켜 굴착하고 버력을 설치된 벨트 컨베이어에 적재하여 후방으로 배출시키며 내부켈리의 작동으로 전진

Cutter Head Jacket: 커터헤드를 둘러싸고 있어서 터널 벽면으로부터 떨어지는 낙반을 방지하며 클램핑 및 리셋팅시에 본체 전방 지지대의 역할과 굴진 중에 커터헤드를 지지하여 본체의 진동을 감소

Inner Kelly: 유압작동으로 커터헤드를 회전/전진시킴(커터헤드 드라이브)

Outer Kelly: 내부켈리를 감싸며 굴착运行时 본체를 지지하는 클램핑 패드장치가 있어 터널 벽면에 압착 지지하여 TBM이 전진하면서 굴착

Trailer: 유압시스템, 버력처리시설로 구성

Open TBM

Cutting style
Rotating button
cutter, weathered
ground

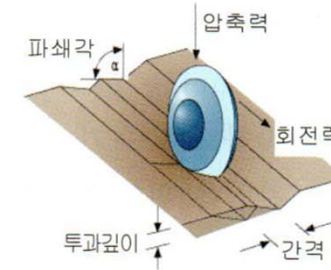
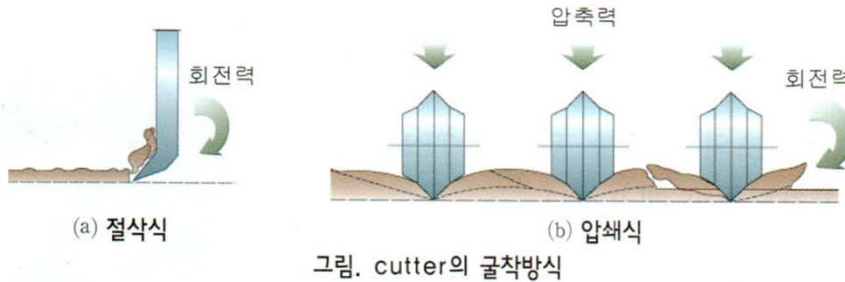

Crushing style
Rotating disk cutter,
harder ground than
cutting style

①		<ol style="list-style-type: none"> 클램핑 패드를 터널 벽면에 압착 기계지지대를 위로 오므림 커터헤드가 작동 시작
②		<ol style="list-style-type: none"> 1-stroke 굴진 완료 내부 켈리의 전진상태
③		<ol style="list-style-type: none"> 기계지지대를 지상으로 내림 클램핑 패드를 터널벽면에서 풀음
④		<ol style="list-style-type: none"> 외부 켈리를 1-stroke 전진 기계지지대로 터널의 굴진방향을 조정

Open TBM

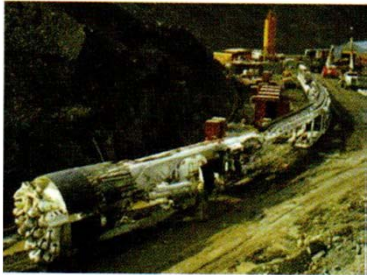

Manufacturing Site

Width = Main TBM width + crane operation width
 Length = Main TBM length + trailer length



Pilot Tunnel (발전터널)

For the first placement not using clamping pad, excavate or blast access having 30cm extra width

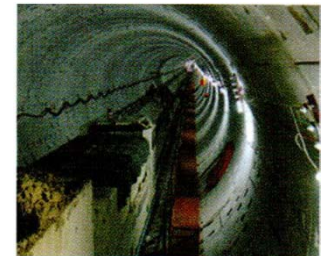

Loss time 이 적어 효율적, 연속적
 버력처리 가능
 고가 초기투자비, 디젤기관차
 환기용량 증가

연속적 버력처리 가능, 가장 효율적
 고가 초기투자비, 벨트의 재사용 곤란, 인원 및 자재
 수송에 별도 시설이 필요

초기투자비 저렴
 환시설비 용량 증가, 연속적인 버력처리가 불가능,
 인원대피 및 덤프트럭 운영을 위한 시설이 필요



(a) Locomotive + 광차(muck car)를 사용하는 경우

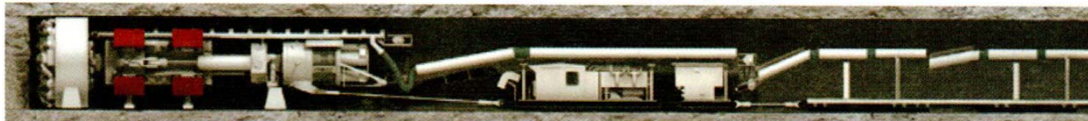

(b) Belt conveyor를 사용하는 경우

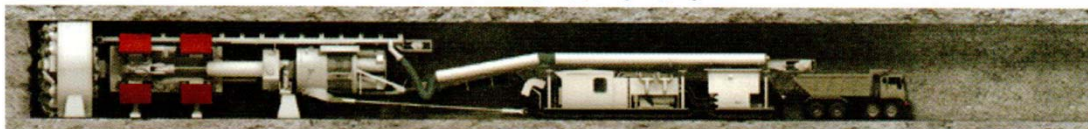

(c) 덤프트럭과 hopper를 사용하는 경우

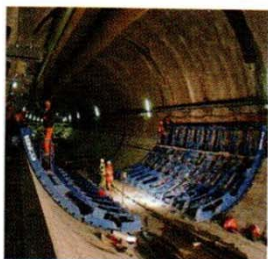

Concrete Lining

Needle beam form: 9-12m, 유압잭에 의해서 이동

Telescopic full round form: 30-36m, 작업대차를 사용하여 이동 및 조립

Shield TBM



Shield TBM

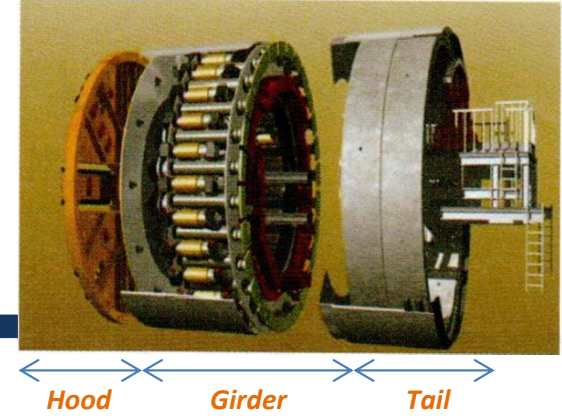

- Hood



- Girder

- 외부 토압 지지, 후드와 테일을 연결, 본체는 테일부 세그먼트의 반력으로부터 거더부 잭의 추진력을 받아서 추진

- Tail

- **스킨 플레이트:** 실드 본체는 굴착, 추진장치를 보호하기 위하여 외곽에 작용하는 토압에 견디도록 스킨 플레이트로 둘러싸고 링 거더 등으로 보강
- **테일 씰:** 스킨 플레이트 내측과 세그먼트 외측의 사이로 뒤채움재, 지하수, 이토사 등이 유입되지 않도록 고무 등의 재료로 설치
- **중절장치:** 급곡선 시공에서는 2단, 3단의 중절장치를 사용하여 곡선부 여굴량을 적게 하고 중절에 의해서 구부리기 쉽도록 함

Shield TBM

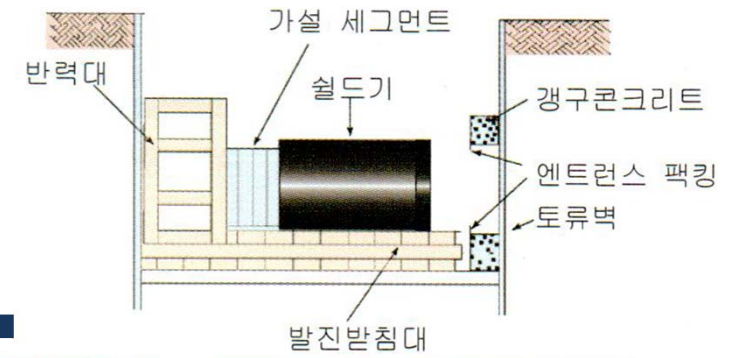

Take off (발진)

Reaction system to push enough and protect adjacent environment and structures

Entrance packing to prevent injection of underground water and soils

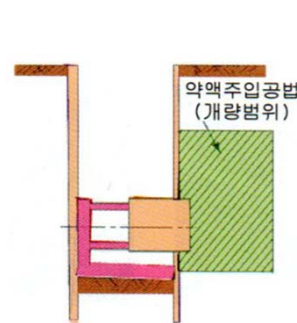

(a) 약액주입공법

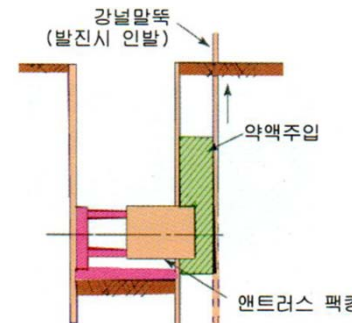

(c) 이중강널말뚝공법

Stabilization of ground for taking off

Segment Placement

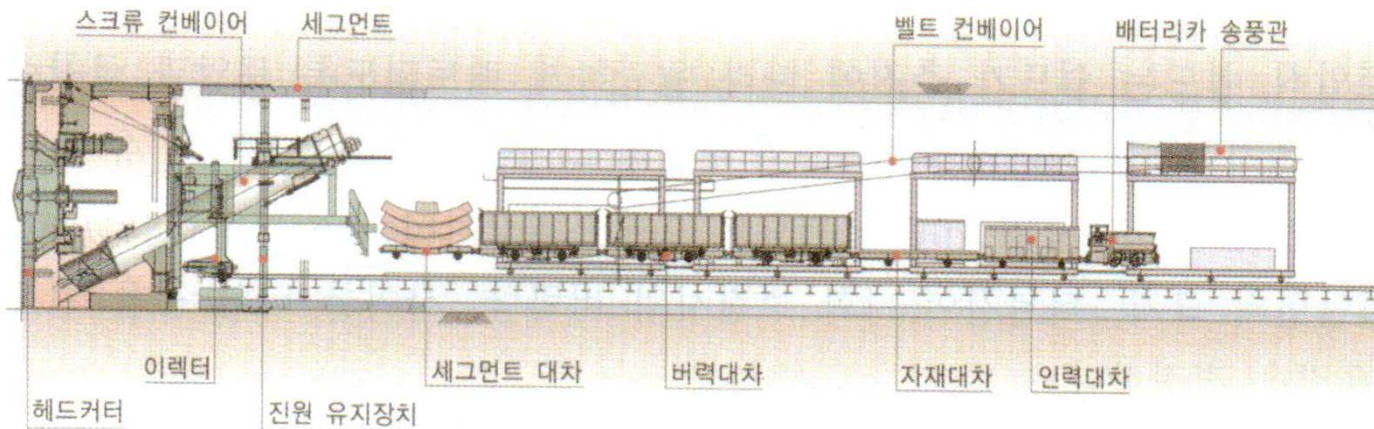

Erector

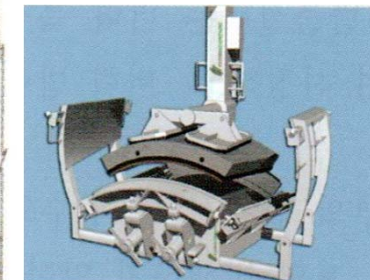

Shield TBM

- Segment Placement

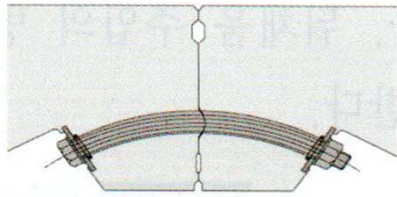

Curved Bolt
Structurally effective

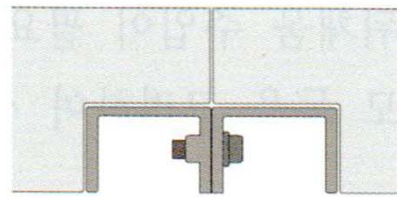

Bolt Box
Corrosion/Loose, Big possible leakage

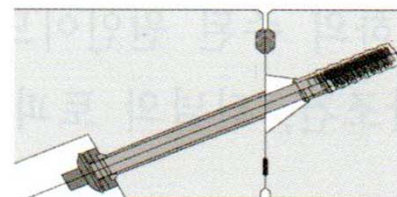

Sloped Bolt
Not fully connected, Weak to twisting, Possible leakage

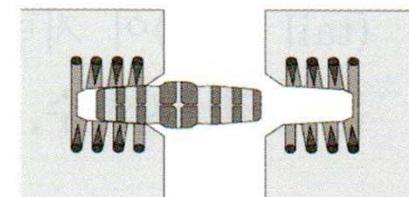

Connection Bar
No corrosion, Possible leakage with time, Impossible to take apart

Backfilling(뒤채움 주입): 세그먼트와 굴착한 지반 사이에서 필연적으로 발생하는 공극을 채움

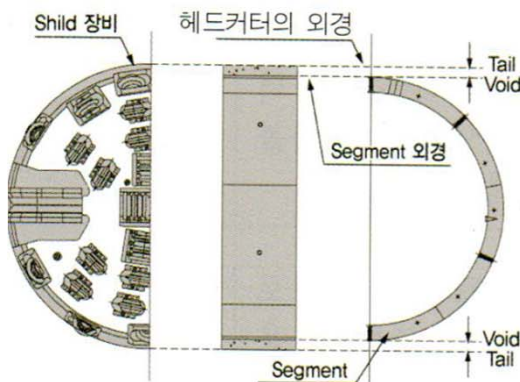

(a) tail void

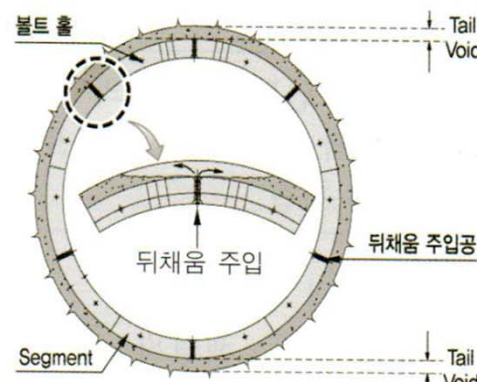

(b) 뒤채움 주입

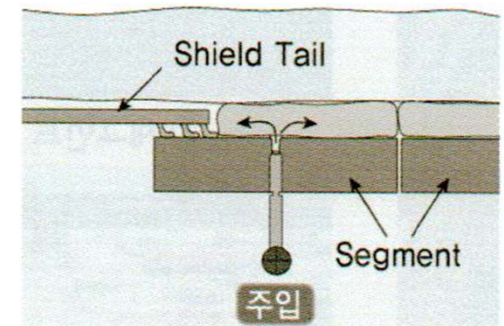

Shield TBM



① 발진작업구



② 실드 조립



③ 후방시설 조립



④ 반력대 설치



⑤ 엔트런스 팩킹 설치

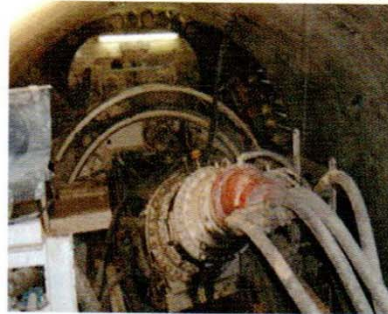

⑥ 실드 굴진



⑦ 세그먼트 조립



⑧ 버력처리



⑨ 뒤채움 주입



⑩ 실드 도달



⑪ 실드기 반출



⑫ 완성단면

Shield TBM

