

[1] Figure shows three systems. System I is a positional servo system. System II is a positional servo system with PD control action. System III is a positional servo system with velocity feedback. Compare the unit-step, unit-impulse, and unit-ramp responses of the three systems. Which system is best with respect to the speed of response and maximum overshoot in the step response?

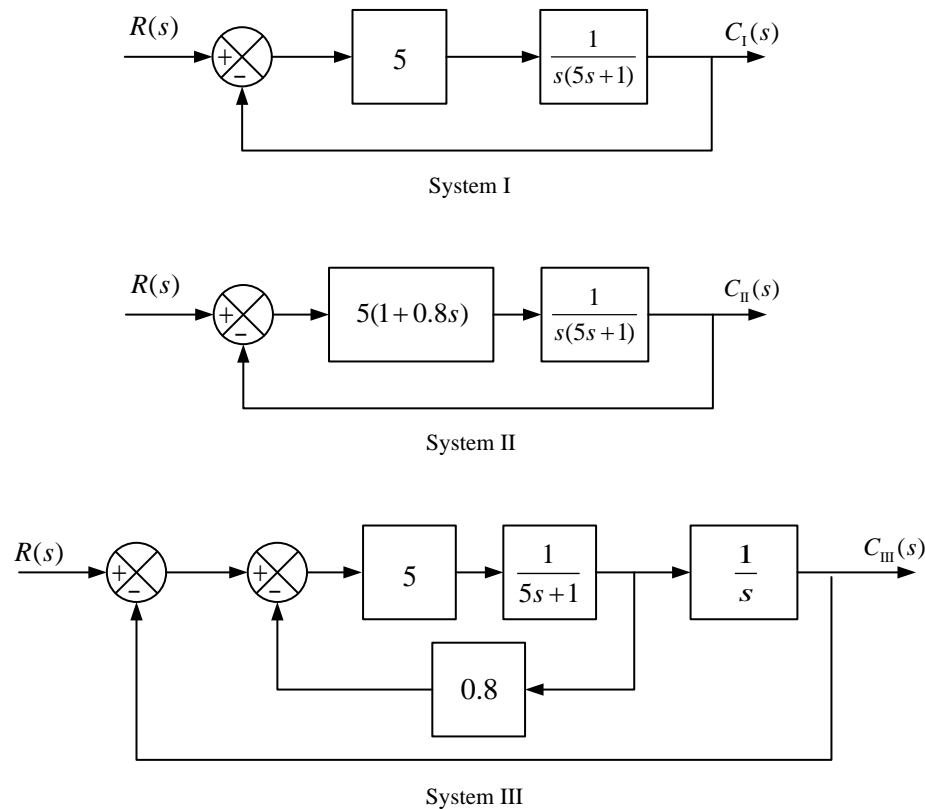

Figure : Positional servo system (System I), positional servo system with PD control action (System II), and positional servo system with velocity feedback (System III).

[2] Consider the closed-loop system shown in Figure below. Determine the range of K for stability. Assume that $K > 0$.

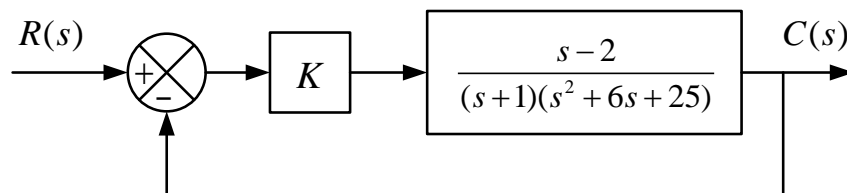

Figure: Closed-loop system.

[3] Consider a unity-feedback control system with the closed-loop transfer function

$$\frac{C(s)}{R(s)} = \frac{Ks + b}{s^2 + as + b}$$

Determine the open-loop transfer function $G(s)$.

Show that the steady-state error in the unit ramp response is given by

$$e_{ss} = \frac{1}{K_v} = \frac{a - K}{b}$$