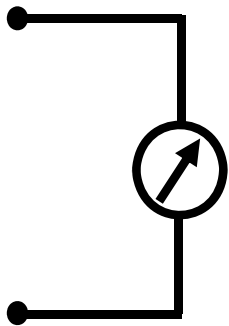

Fig. 1 Schematic draw of d'Arsonval meter



Note) The d'Arsonval meter is expressed as a resistor.

Fig. 2 Symbol of d'Arsonval meter

[1] d'Arsonval meter는 그림 1과 같이 흐르는 전류에 비례하여 바늘(pointer)이 회전한다. D'Arsonval meter를 기본 유닛으로 하여 전압계와 전류계를 제작하여 전압 또는 전류를 측정한다. 바늘이 최대 눈금 (full scale)을 가리킬 때 정격전류가 흐르고 있고 그때 d'Arsonval meter에서의 전압강하를 정격전압이라 한다. 이 값들로부터 d'Arsonval meter의 저항을 알 수 있고, 그림 2와 같은 기호를 쓴다. (20점)

- (a) D'Arsonval meter의 정격전압이 50 mV 이고, 정격전류가 1 mA일 때 d'Arsonval meter의 저항을 구하라. (4점)
- (b) 분압 회로를 이용하여 저항과 d'Arsonval meter를 직렬로 연결하여 전압계를 구성할 수 있다. (b-1) 20 V를 full scale로 읽으려 할 때 그 회로도를 그려라. (2점) (b-2) 직렬로 연결되는 저항을 구하라. (2점) (b-3) 이때 전압계의 내부저항은 몇 옴인가? (2점)
- (c) (b)와 같이 d'Arsonval meter로 전압계를 구성할 경우, 100 V를 full scale로 읽으려 할 때 (c-1) 직렬로 연결되는 저항을 구하라. (2점) (c-2) 이때 전압계의 내부저항은 몇 옴인가? (2점)
- (d) 분류 회로를 이용하여 저항과 d'Arsonval meter를 병렬로 연결하여 전류계를 구성할 수 있다. 100 mA를 full scale로 읽으려 할 때 (d-1) 그 회로도를 그리고 (2점) (d-2) 병렬로 연결되는 저항을 구하라. (2점) (d-3) 이때 전류계의 내부저항은 몇 옴인가? (2점)

답안 작성 방법 : 답안지에 계산과정을 쓰고 답을 구한 뒤, 아래의 표와 같이 정리하고 단위도 정확히 기입할 것. (b-1), (d-1) 문제는 회로도를 그릴 것.

[1] In d'Arsonval meter, the rotation of pointer is proportional to the current flowing through the device (Figure 1). Using d'Arsonval meter, one can configure voltmeter or ammeter. When the pointer indicates at the full scale, the current flow and the voltage drop of the device is called to be rated current and rated voltage, respectively. From these rated values, one can identify the resistance of d'Arsonval meter. Figure 2 show the circuit symbol of d'Arsonval meter. (20 pts)

- (a) Given that the rated voltage and rated current are 50 mV and 1 mA, respectively, find the resistance of d'Arsonval meter. (4 pts)
- (b) One can implement voltmeter by constructing voltage-dividing circuit, which is a combination of d'Arsonval meter in series with a resistor. Assume that one wants to read 20 V at the full scale of d'Arsonval meter. (b-1) Draw the circuit. (2 pts) (b-2) Find the value of the series resistor. (2 pts) (b-3) Find the internal resistance of the voltmeter. (2 pts)
- (c) One wants to implement voltmeter using d'Arsonval meter and a series resistor as in (b). Assume that one wants to read 100 V at the full scale of d'Arsonval meter this time. (c-1) Find the value of the series resistor. (2 pts) (c-2) Find the internal resistance of the voltmeter. (2 pts)
- (d) One can implement ammeter by constructing current-dividing circuit, which is a combination of d'Arsonval meter in parallel with a resistor. Assume that one wants to read 100 mA at the full scale of d'Arsonval meter. (d-1) Draw the circuit. (2 pts) (d-2) Find the value of the parallel resistor. (2 pts) (d-3) Find the internal resistance of the ammeter. (2 pts)

How to fill in the answer sheet : Write down calculation processes and the answers in the answer sheet and summarize answers as shown below. Units also should be specified. Draw circuits for question (b-1) and (d-1).

(a) 4 pts	(b-2) 2 pts	(b-3) 2 pts	(c-1) 2 pts	(c-2) 2 pts	(d-2) 2 pts	(d-3) 2 pts

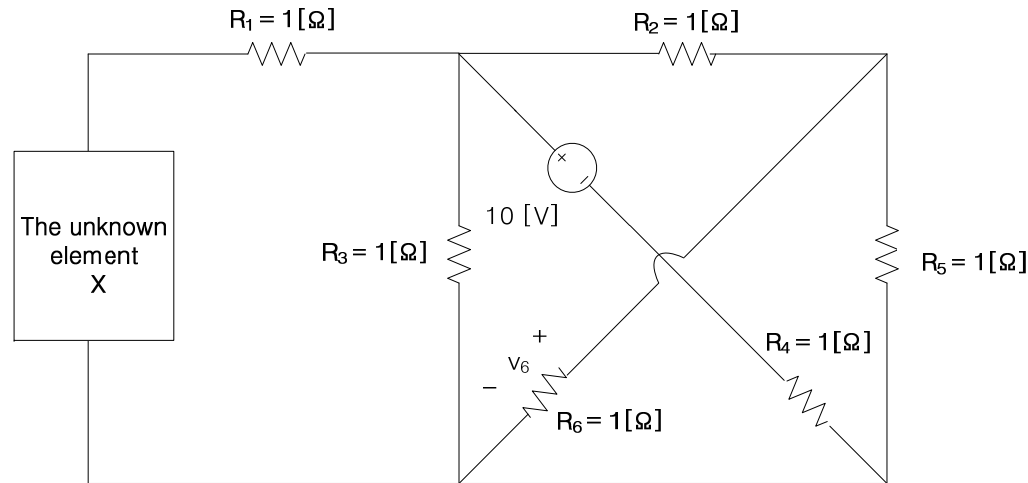
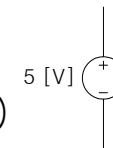

Fig. 1 A circuit containing an unknown element X

[2] 각각의 경우에 Mesh analysis 를 이용하여  $R_6$  저항에 걸리는 전압을 구하십시오. (20점)

(a) The unknown element X 가 5 [V] 독립 전압원 이다. 단, +단자가  $R_1$  쪽을 향한다. (6점)



(b) The unknown element X 가 3 [A] 독립 전류원 이다. 단, 전류의 방향이  $R_1$  쪽을 향한다. (6점)



(c) The unknown element X 가  $i_x = 5v_6$  의 관계를 갖는 종속 전류원 이다. 단, 전류의 방향이  $R_1$  쪽을 향한다. (8점)



[2] Determine the voltage across the resistor  $R_6$  using Mesh analysis. (20 pts)

(a) Given the unknown element X is an independent 5 [V] voltage source. i.e. positive side contacts  $R_1$ . (6 pts)

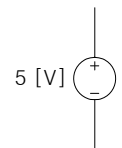

(b) Given the unknown element X is an independent 3 [A] current source. i.e. current into  $R_1$ . (6 pts)



(c) Given the unknown element X is a dependent current source whose current is  $i_x = 5v_6$ . i.e. current into  $R_1$ . (8 pts)



[3] Fig. 1, 2, 3 의 회로에서 a-b terminal 오른쪽 소자는  $i = \frac{v^2}{8}$  의 관계를 갖는 소자이다. 아래의 질문에 답하시오. (20점)

- (a) Fig. 1 의 회로에서  $v$ 와  $i$ 를 구하시오. (6점)
- (b) Fig. 2 의 회로에서  $v$ 와  $i$ 를 구하시오. (5점)
- (c) Fig. 3 의 회로에서  $v$ 와  $i$ 를 구하시오. (5점)
- (d) (a), (b), (c) 의 결과에서 superposition method 가 성립하는지 여부를 확인하시오. 또, 그 이유는 무엇인지 설명하시오. (4점)

[3] The devices to the right of terminals a-b in Fig. 1, 2, and 3 are devices characterized by  $i = \frac{v^2}{8}$ . Answer the following questions. (20 pts)

- (a) At Fig. 1, find  $v$  and  $i$ . (6 pts)
- (b) At Fig. 2, find  $v$  and  $i$ . (5 pts)
- (c) At Fig. 3, find  $v$  and  $i$ . (5 pts)
- (d) From the results of (a), (b) and (c), check if superposition method is valid. Explain why. (4 pts)

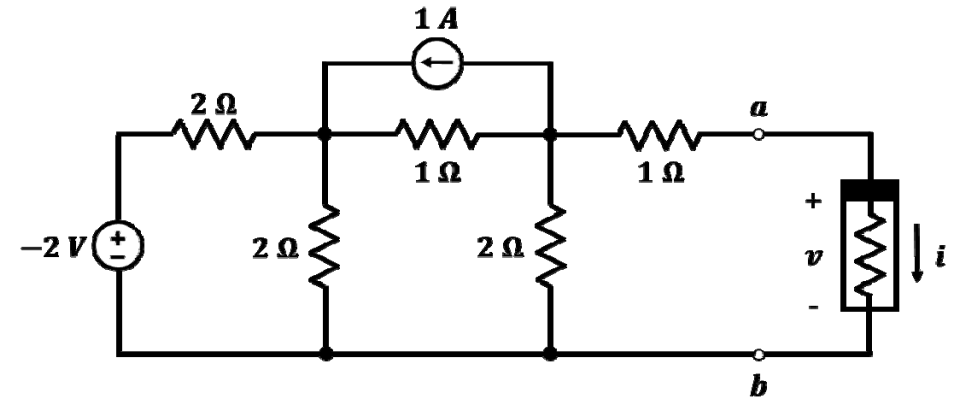

Fig. 1 A circuit for (a)

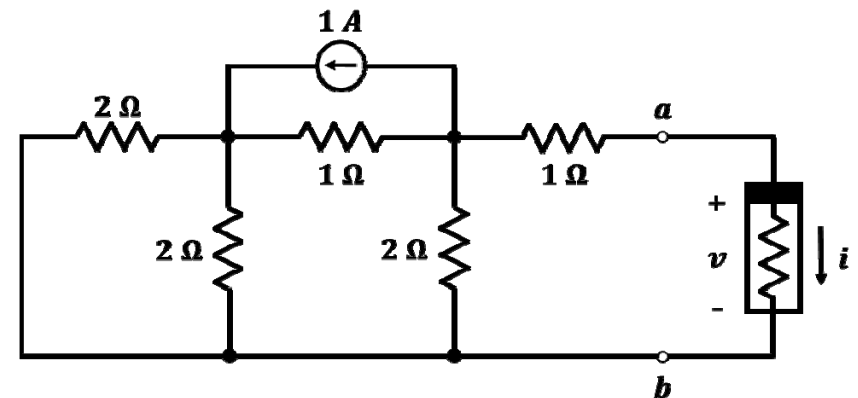

Fig. 2 A circuit for (b)

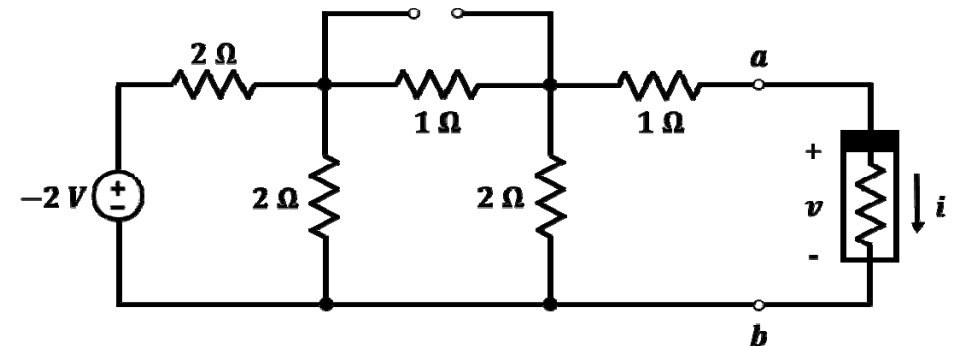

Fig. 3 A circuit for (c)

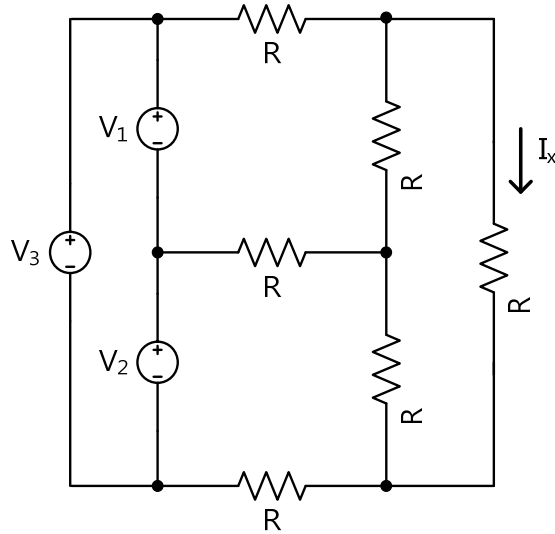

Fig. 1 A Circuit with 3 Sources.

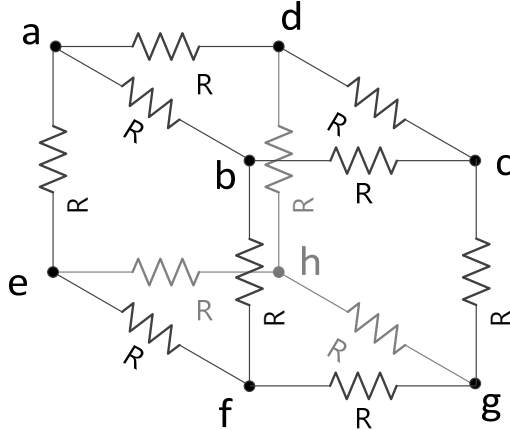

Fig. 2. A Cubic Circuit.

[4] 다음의 회로에서 각 질문에 답하십시오. (20점)

- (a) Fig. 1에서  $R=1\text{ohm}$ ,  $V_1=1\text{[V]}$ ,  $V_2=2\text{[V]}$ ,  $V_3=3\text{[V]}$  일 때,  $I_x$ 를 구하십시오. 단, Superposition을 이용하지 않고 풀 것. (6점)
- (b) Fig. 1에서  $R=1\text{ohm}$ ,  $V_1=1\text{[V]}$ ,  $V_2=2\text{[V]}$ ,  $V_3=3\text{[V]}$  일 때,  $I_x$ 를 구하십시오. 단, Superposition을 이용하여 풀 것. 힌트, 전원의 독립성을 고려하십시오. (7점)
- (c) Fig. 2에서  $R=1\text{ohm}$  일 때, Node a 와 Node c 사이의 등가 저항을 구하십시오. Hint: 평면화와 대칭성을 이용한다. (7점)

[4] Answer the following questions. (20 pts)

- (a) At Fig. 1, find  $I_x$  when  $R$  is  $1\text{ohm}$ ,  $V_1=1\text{[V]}$ ,  $V_2=2\text{[V]}$ ,  $V_3=3\text{[V]}$ . Do not use superposition method. (6 pts)
- (b) At Fig. 1, find  $I_x$  when  $R$  is  $1\text{ohm}$ ,  $V_1=1\text{[V]}$ ,  $V_2=2\text{[V]}$ ,  $V_3=3\text{[V]}$ . Use superposition method. Hint : consider the independence of voltage sources. (7 pts)
- (c) At Fig. 2, find the equivalent resistance between node a and node c when  $R$  is  $1\text{ohm}$ . Hint : Use planarization and symmetry. (7 pts)