

# **Overview of Earthquake Engineering**

**Hong-Gun Park**  
**Seoul National University**

# contents

1. Causes and damages
2. Principles of earthquake design
3. Design considerations
4. Earthquakes in Korean Peninsular

# 1. Causes and damages

## Recent earthquakes

- Kobe EQ
  - Magnitude 7.2
  - 1995. 1.17
  - Death 5500
  - Injury 40,000
  - loss 9,600 billion yen
- Turkey EQ
  - M 7.8
  - 1999. 8. 17
  - Death 12,000
  - Injury 6,000
- Taiwan 921 EQ
  - M 7.3
  - 1999. 9. 21
  - Death 2,000
  - Injury 3,000



# Recent major earthquakes

Date	Location	Death	Magnitude	major damage
1906.04.18	US, San Fransico	3000+	7.8	fire
1923.09.01.	Japan, Tokyo	100000	8.3	
1976.07.27.	China, Tangsan	655000	7.9	biggest damage in recent years
1985.09.19.	Mexico, Mexicocity	10000	8.1	soft soil effect
1988.12.07.	Armania, 스피탁	25000	7.0	
1990.06.20.	Iran, 카스피해연안	40000	7.3	
1995.01.17.	Japan, Kobe	25000	7.2	epicenter at city center Vertical vibration
1999.08.17	Turkey, 이즈미	12000	7.8	
1999.09.21	Taiwan	2000	7.3	
2000.01.26	India, 구자트라	25000		
2003.12.26	Iran, 동남부	26000	6.5	
2004.12.26	Indonesia, Sumatra	234000	9.0	Tsunami
2005.10.08	Pakistan, 동북부	18000	7.6	
2008.05.12.	China, Sichuan	80000	7.8	Intraplate EQ
2010.01.12.	Haiti, 포르토프랭스	150000	7.2	
2011.03.11	Japan, Tohoku EQ	27000	9.0+	Biggest in history NPT damages Long duration vibration

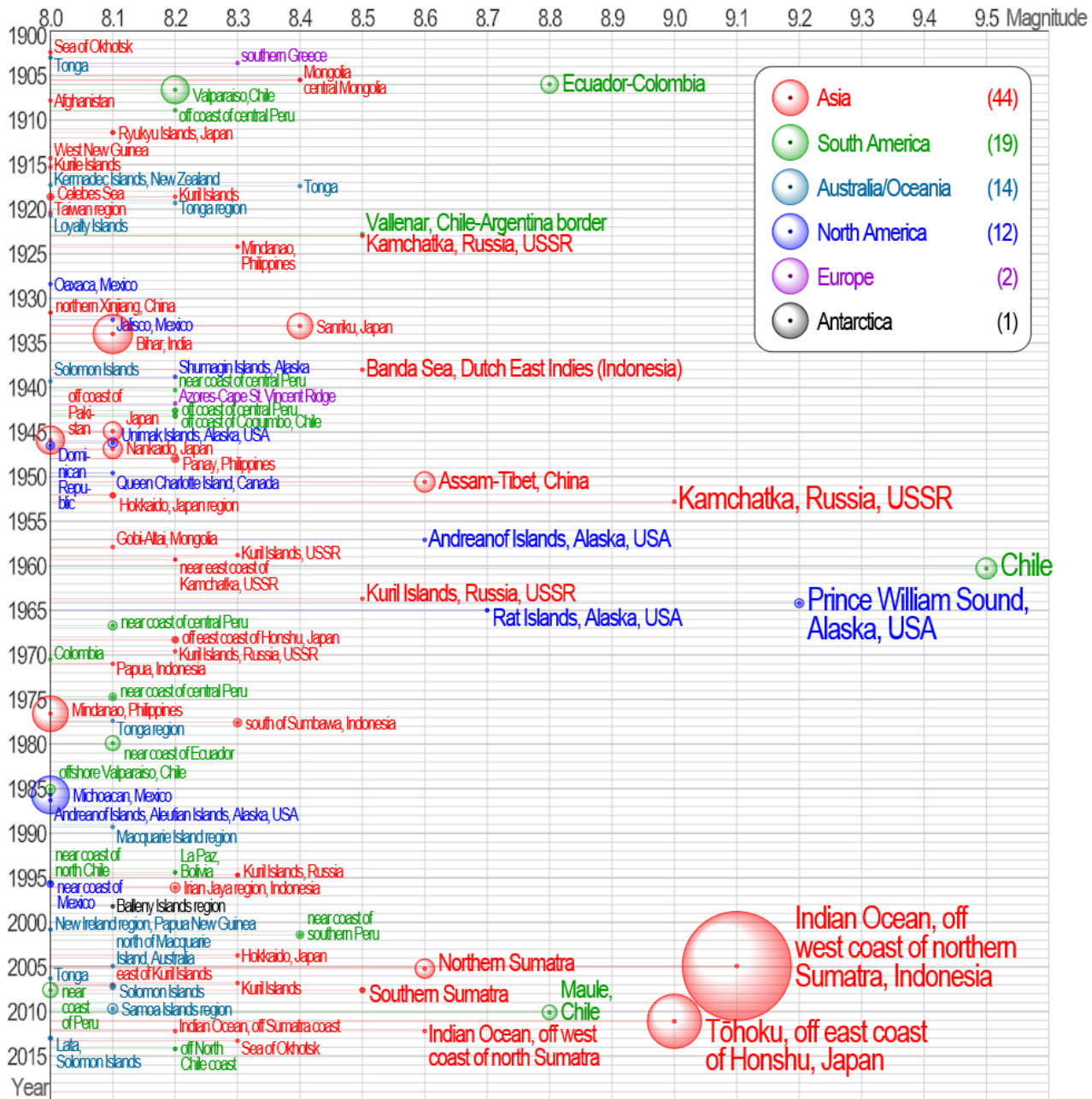

# Losses per EQ

Nations	Total Death toll	Number of EQ greater than M6	Ave. death per EQ
China	1.9 million	9	210,000
India	0.33 million	3	110,000
Iran	0.11 million	14	8,000
Japan	0.17 million	17	10,000
USA	0.001 million	14	70

Losses : EQ Magnitude



population density



industry development



preparation is important  
earthquake design  
and strengthening

# Movement of earth crusts (tectonic plate movement)

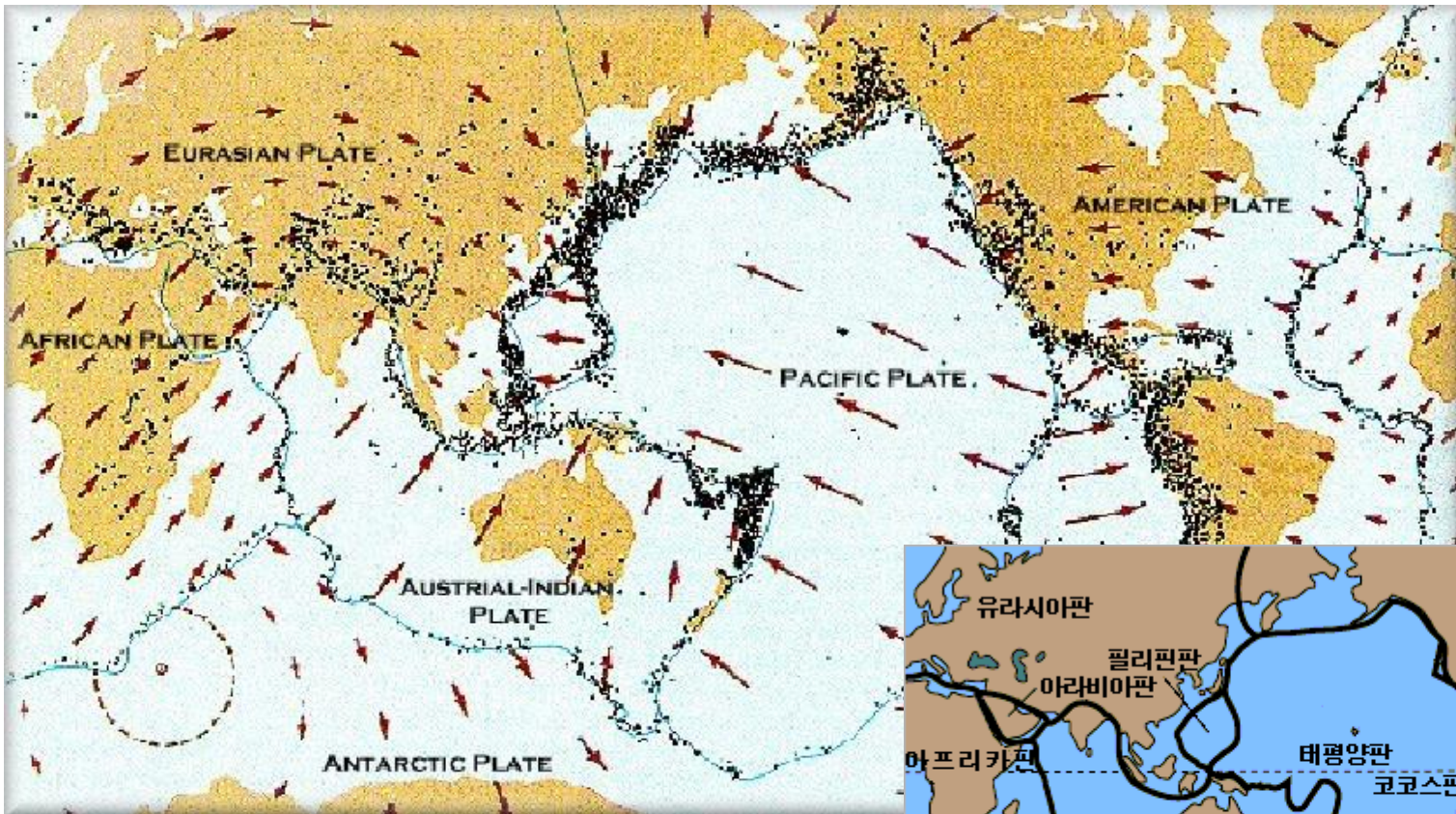

Convection of melted magma

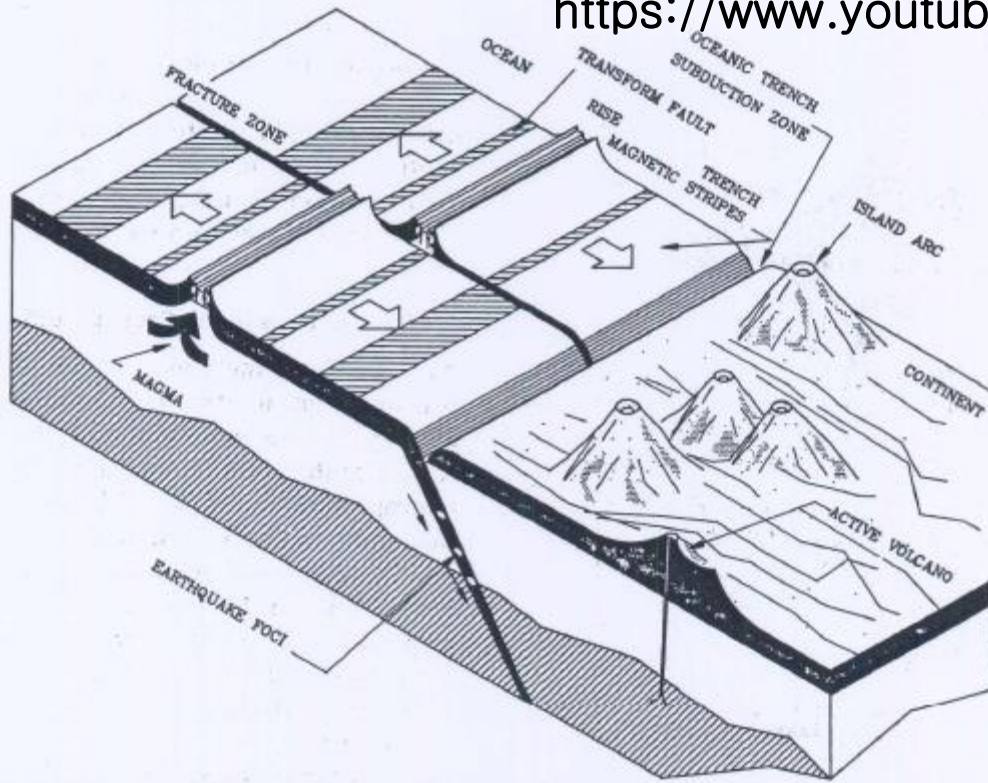

Subduction zone

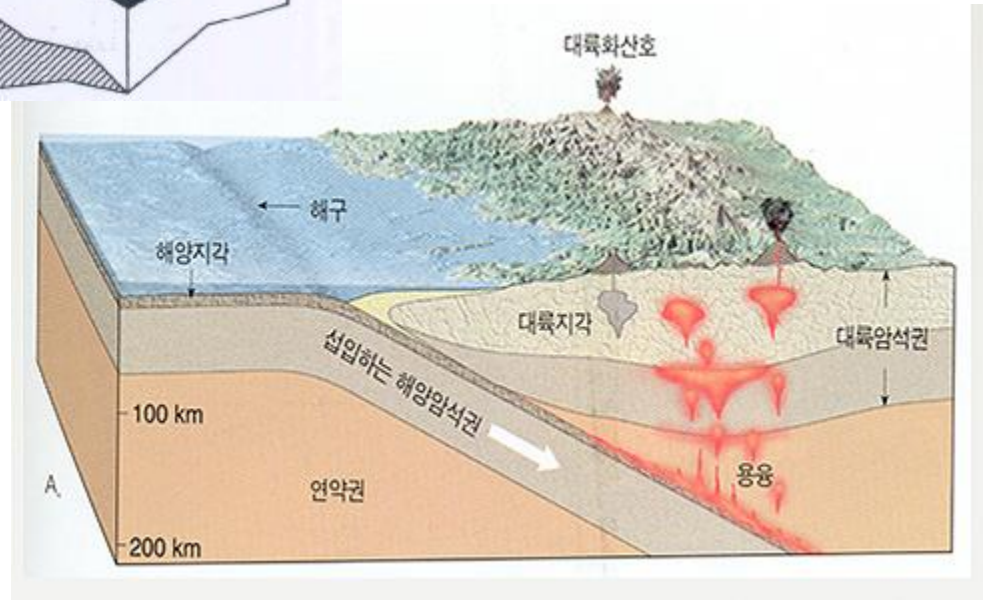
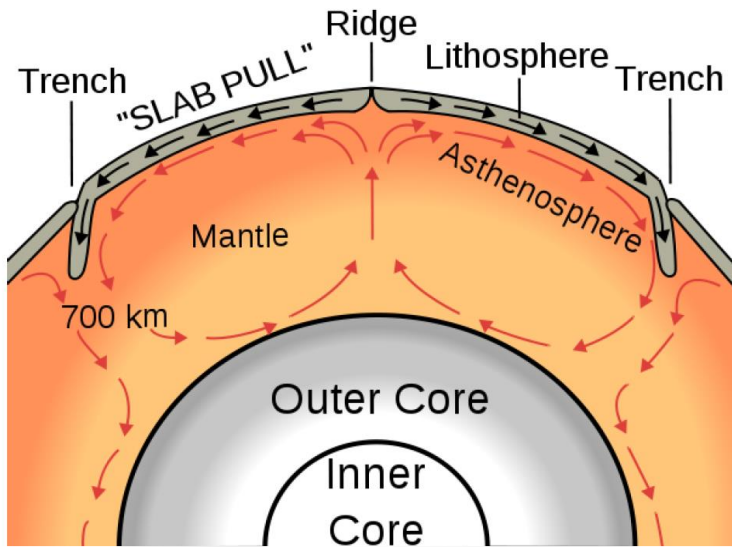



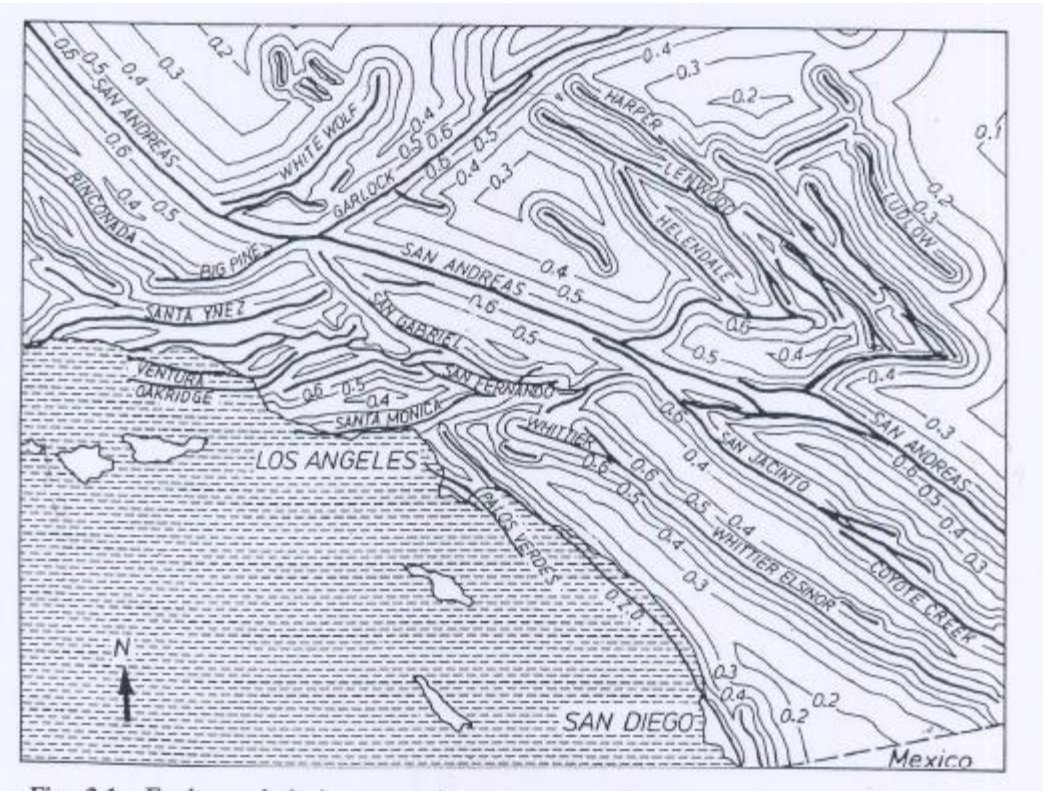
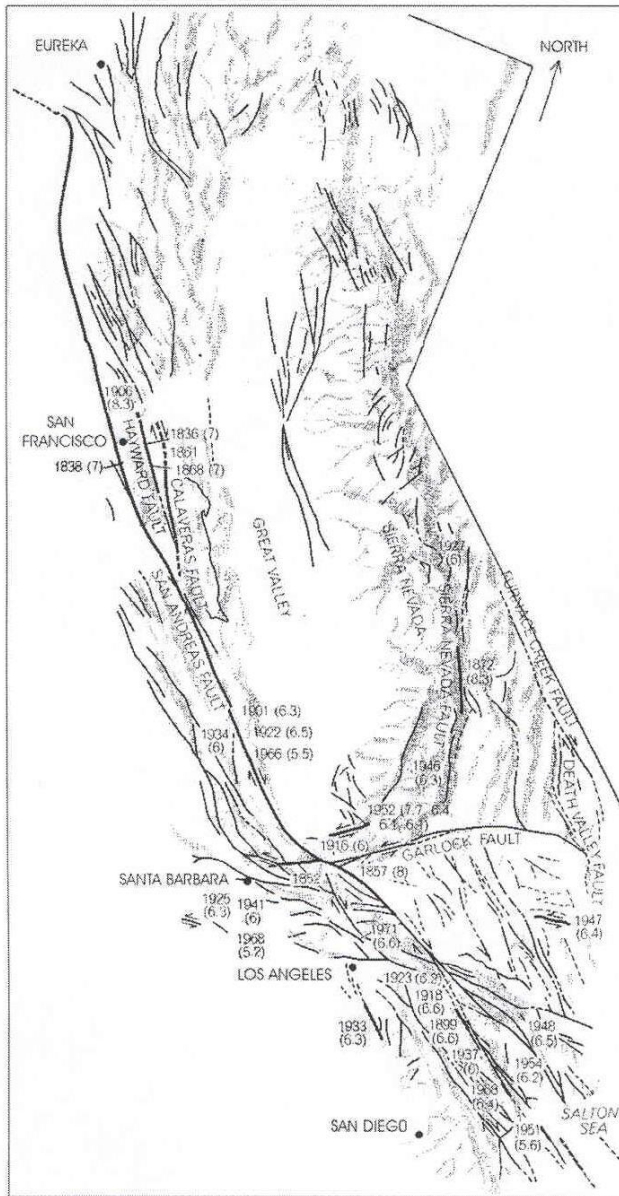

California in US

Lateral faults, transform boundary

Figure 1-7. A simplified fault map of California. (From *The San Andreas Fault*, by Don L. Anderson. Copyright 1971 by Scientific American, Inc. All rights reserved.)

FAULT LINE

DIP

FOOTWALL

HANGING WALL

(a)

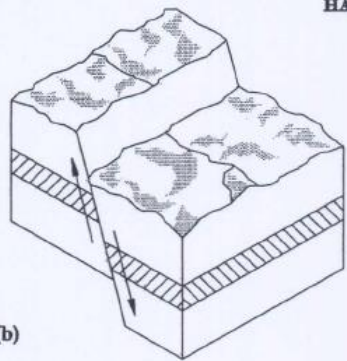

(b)

**NORMAL FAULT**

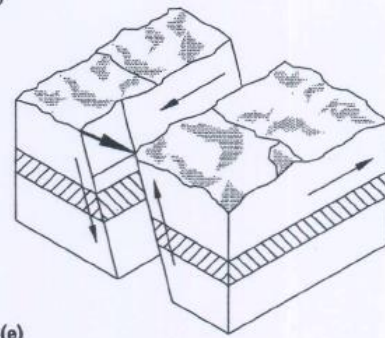

(e)

**LEFT LATERAL NORMAL FAULT  
(LEFT OBLIQUE NORMAL FAULT)**

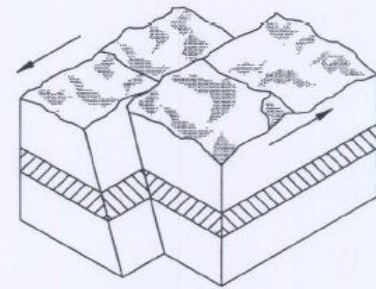

(d)

**LEFT LATERAL FAULT**

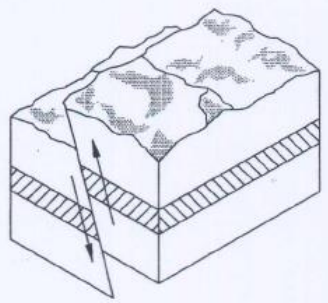

(c)

**REVERSE FAULT**

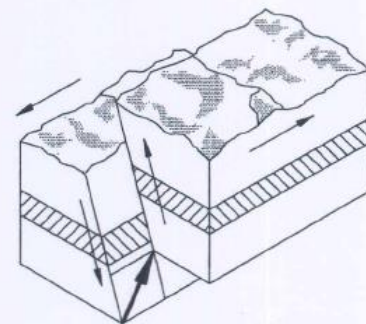

(f)

**LEFT LATERAL REVERSE FAULT  
(LEFT OBLIQUE REVERSE FAULT)**

# earthquake

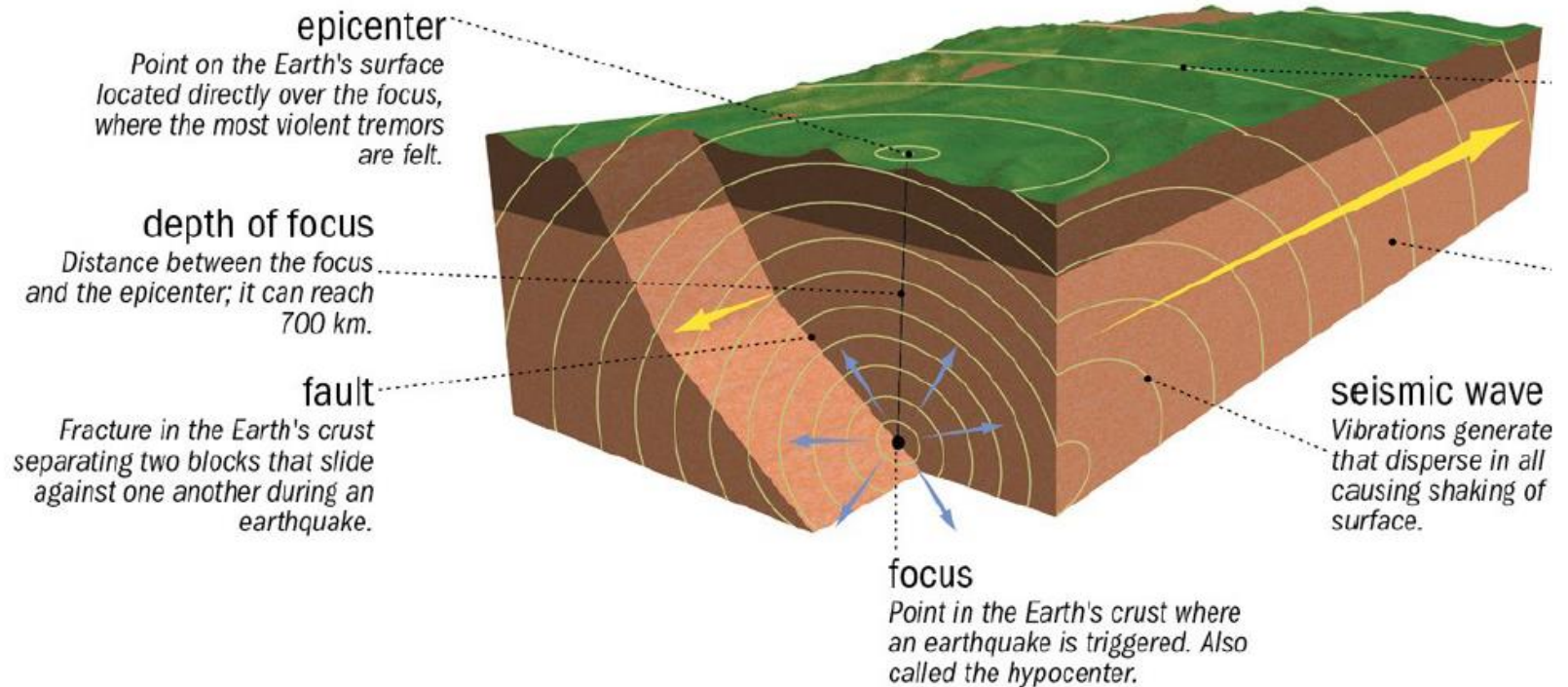

# Seismic waves : body waves and surface waves

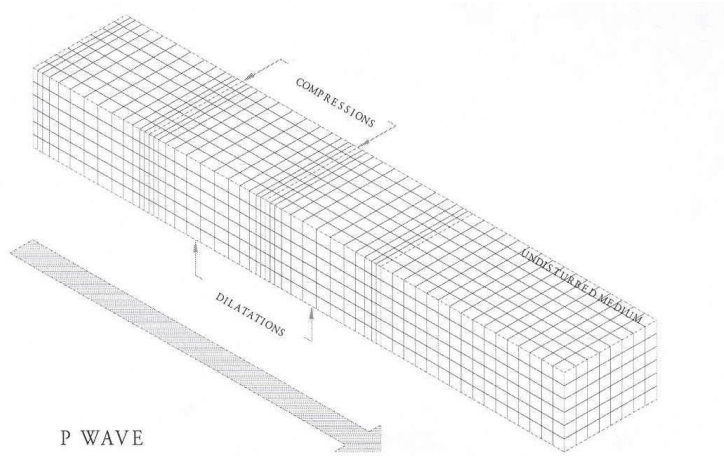

Figure 1-11. Ground Motion near the ground surface due to P waves. (From *Nuclear Explosions and Earthquakes*, by Bruce A. Bolt. Copyright 1976 W. H. Freeman and Company. Used with Permission.)

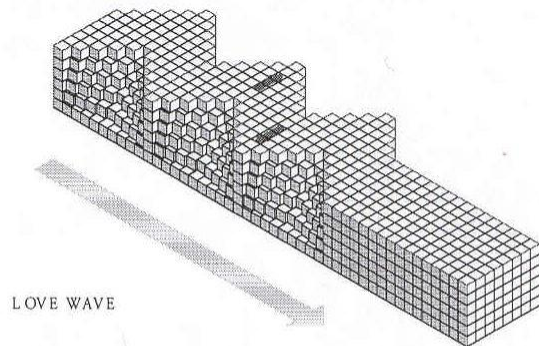

Figure 1-13. Ground motion near the ground surface due to Love waves. (From *Nuclear Explosions and Earthquakes*, by Bruce A. Bolt. Copyright 1976 W. H. Freeman and Company. Used with Permission.)

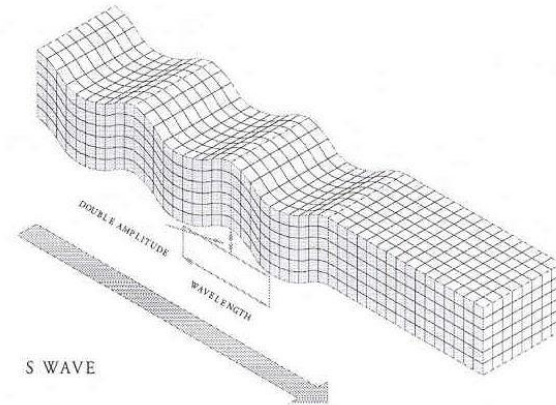

Figure 1-12. Ground motion near the ground surface due to S waves. (From *Nuclear Explosions and Earthquakes*, by Bruce A. Bolt. Copyright 1976 W. H. Freeman and Company. Used with Permission.)

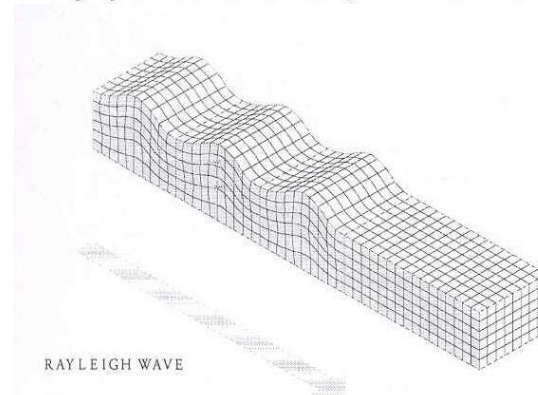
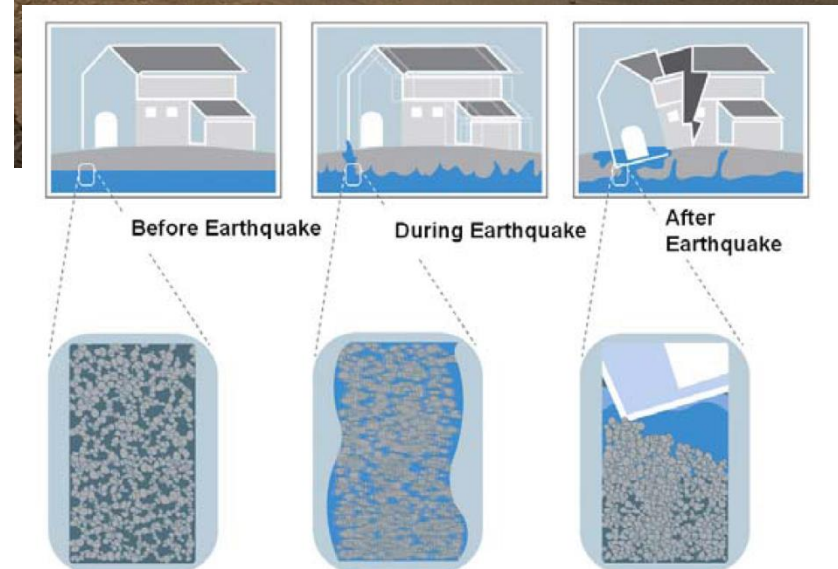

Figure 1-14. Ground motion near the ground surface due to Rayleigh waves. (From *Nuclear Explosions and Earthquakes*, by Bruce A. Bolt. Copyright 1976 W. H. Freeman and Company. Used with Permission.)

# Direct damage : soil failure



지반의 액상화(liquefaction)  
Liquefaction occurs when  $M > 6.0$

Fig. 4. Soil liquefaction process

# Direct damage : land slide, snow slide

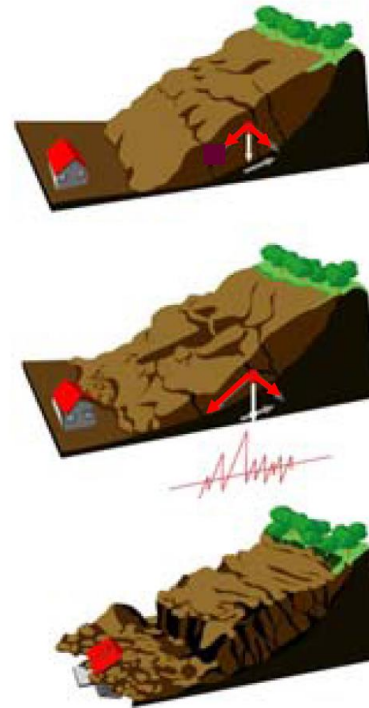
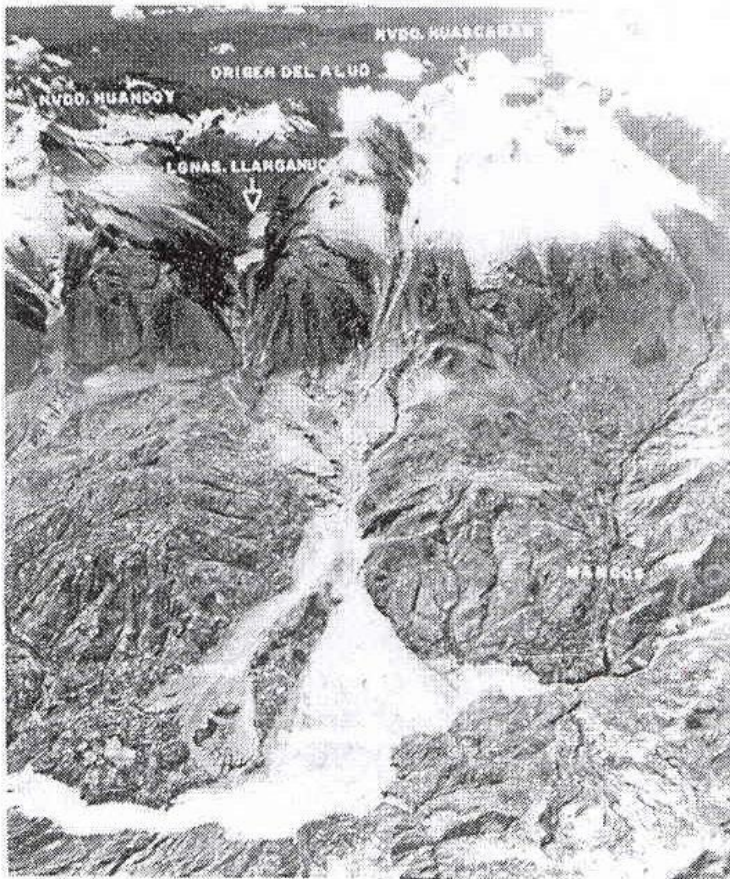

Fig. 1. Landslide caused by earthquake

Figure 1-19. Aerial view of Mt. Huascarán and the debris avalanche that destroyed Yungay and Ranrahirca in May 1970 Peru earthquake. (Photo courtesy of Servicio Aerofotografico National de Peru and L. Cluff.)

# Direct damage : ground uplift, distortion

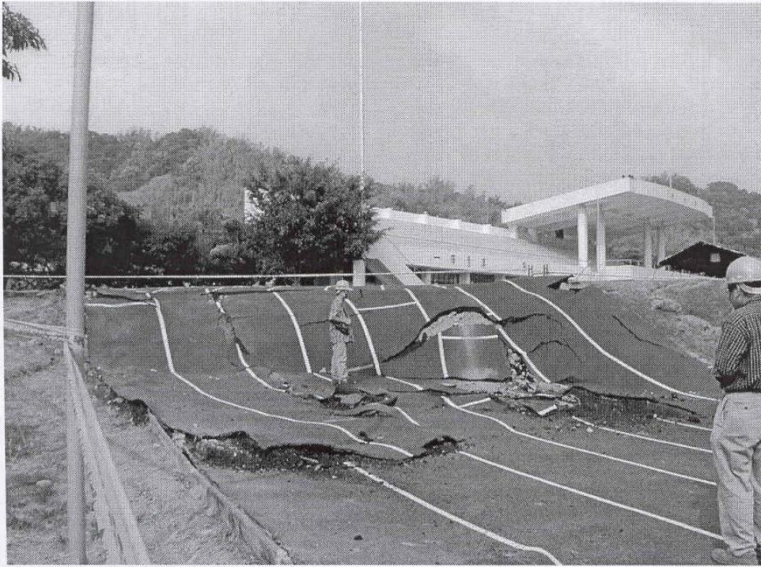
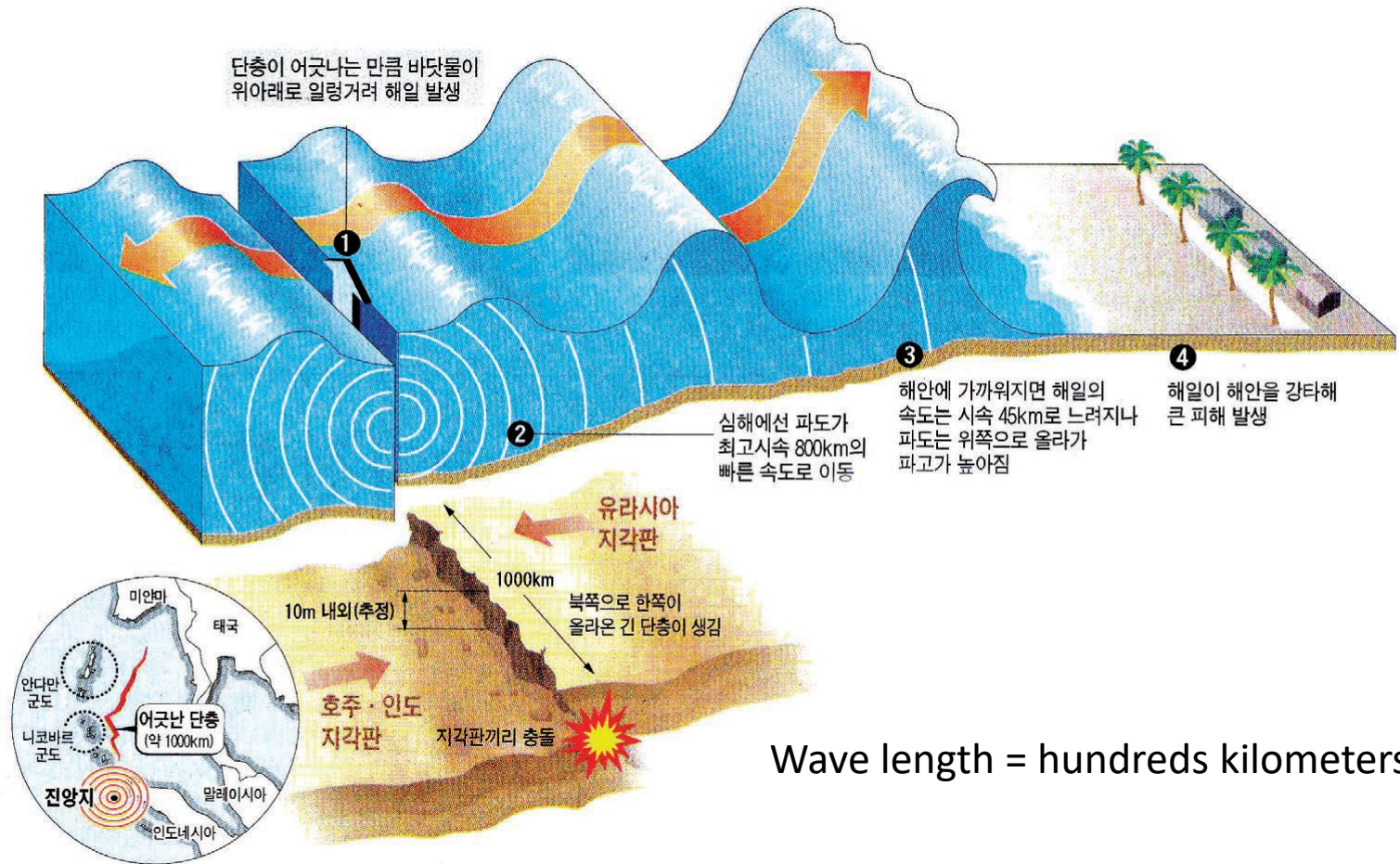

Figure. 1-20 Ground uplift along the fault in the 1999 Chi-Chi Earthquake (Photo by Dr. Farzad Naeim).



# Indirect damage : Tsunami





## Tsunami Damage in Hawaii caused by 1960 Alaska EQ



Before tsunami



After tsunami

*Figure 1-21* Damage at Hilo, Hawaii, due to tsunami of May 23, 1960. (Photos courtesy of R. L. Wiegel.)

# Tsunami in 2004 Indonesia Sumatra



# Tsunami in 2004 Indonesia Sumatra



**BANDA ACEH SHORELINE**  
6/23/2004



**BANDA ACEH SHORELINE**  
12/28/2004

# Tsunami in 2011 Japan Tohoku EQ

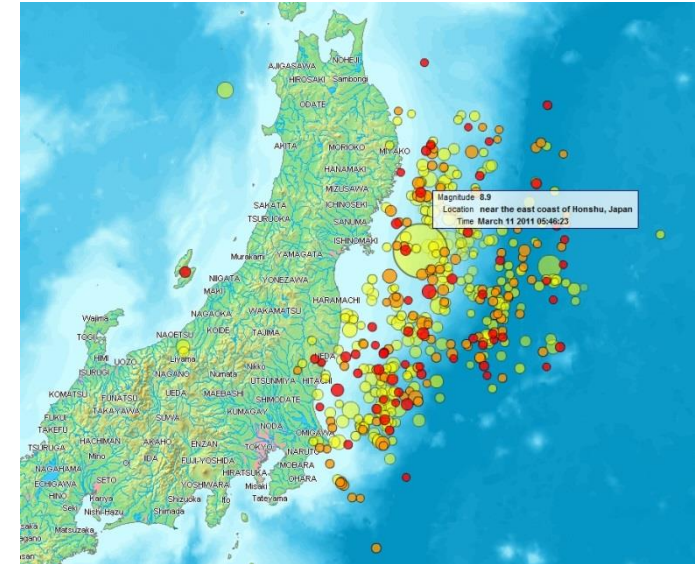

## Tsunami Travel Times

Tsunami travel time contours in hours, beginning from the earthquake origin time.

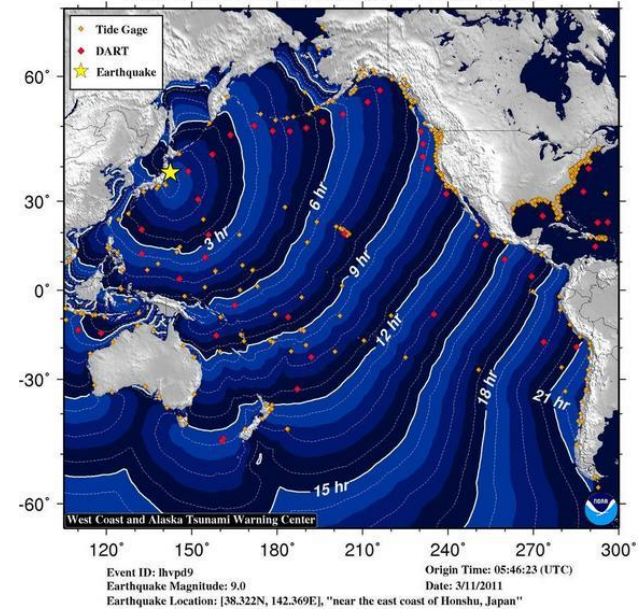

Nuclear power plants were destroyed.  
Not by EQ but by tsunami  
Diesel engine for cooling down the nuclear  
power heat was flooded.

# Indirect damage : fire



**San Francisco, 1906, M=7.8**



**Northridge, 1994**



breakdown of Gas pipes, Electric lines, and water lines



# Direct damage : vibration of buildings

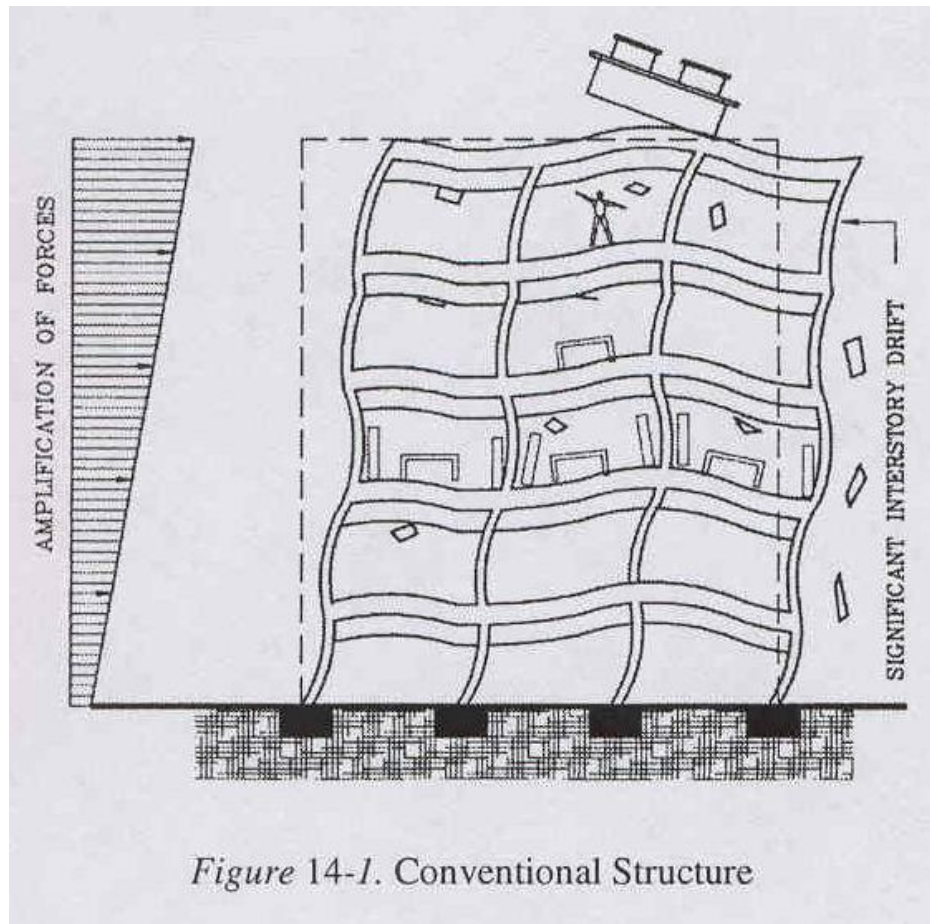

- Chile Earthquake, 2010 M=8.8



# ■ Nepal Earthquakes, 2015.04, M=7.8

- In Nepal, there were many prominent cultural heritages. And some of them were registered as UNESCO world heritage.
- Several temples on Kathmandu Durbar Square, a UNESCO World Heritage Site, and also Dharahara tower, built in 1832, collapsed

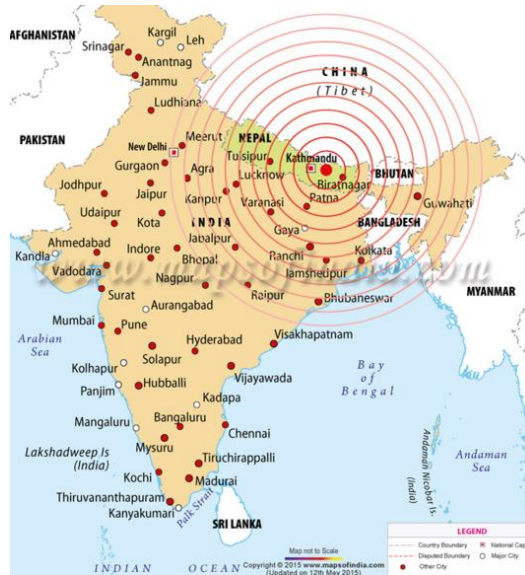



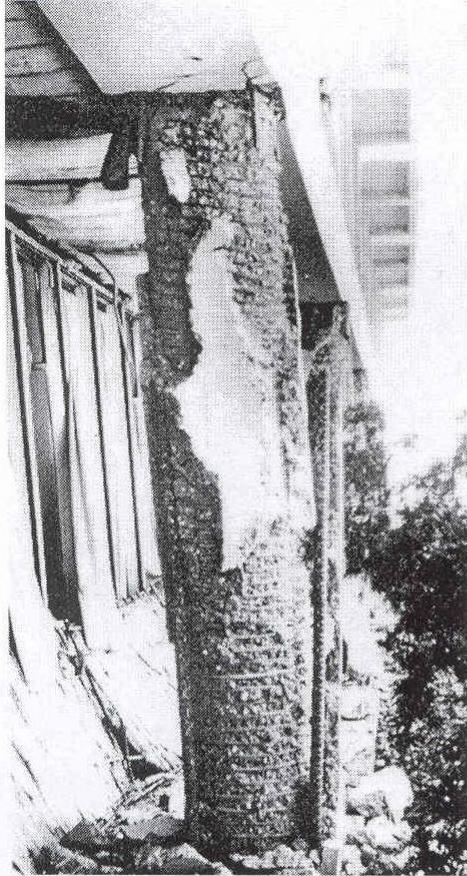

(b)

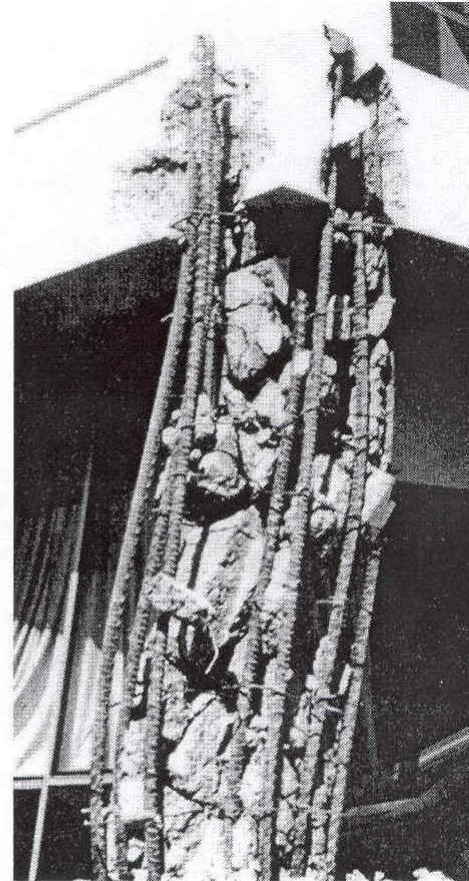

(c)

*Figure 10-18.* Damage to columns of the 4-story Olive View Hospital building during the February 9, 1971 San Fernando, California, earthquake. (From Ref. 10-38.) (a) A wing of the building showing approximately 2 ft drift in its first story. (b) Spirally reinforced concrete column in first story. (c) Tied rectangular corner column in first story.

## 2. Principles of earthquake design

Earthquake load = inertia force caused by ground vibration

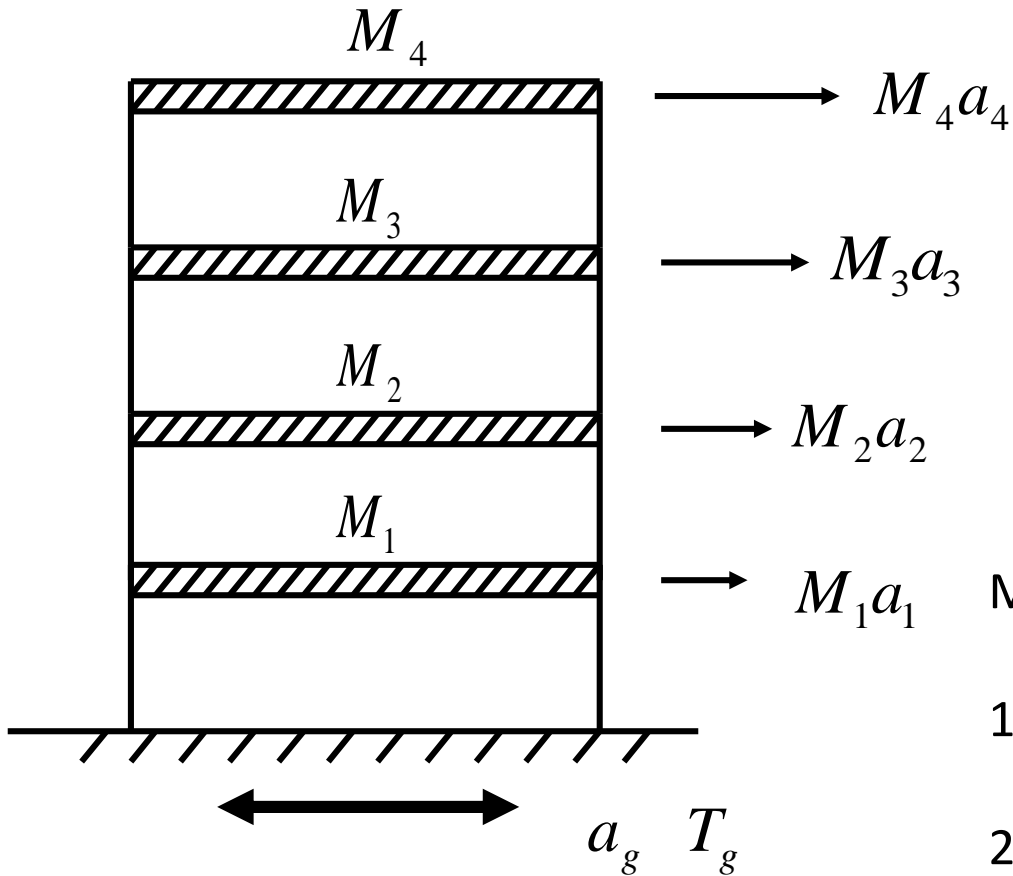

$$F = ma$$

$$m(a + a_g) + cv + ku = 0$$

$$ma + cv + ku = -ma_g$$

$$T = 2\pi \sqrt{\frac{M}{K}}$$

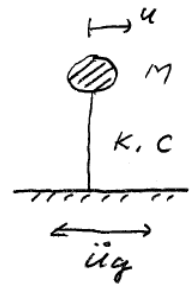

Major parameters

1. Ground accel. (regional effect)  $a_g$

2. resonance (cyclic effect)  $T_g$  vs  $T$

# inertia force

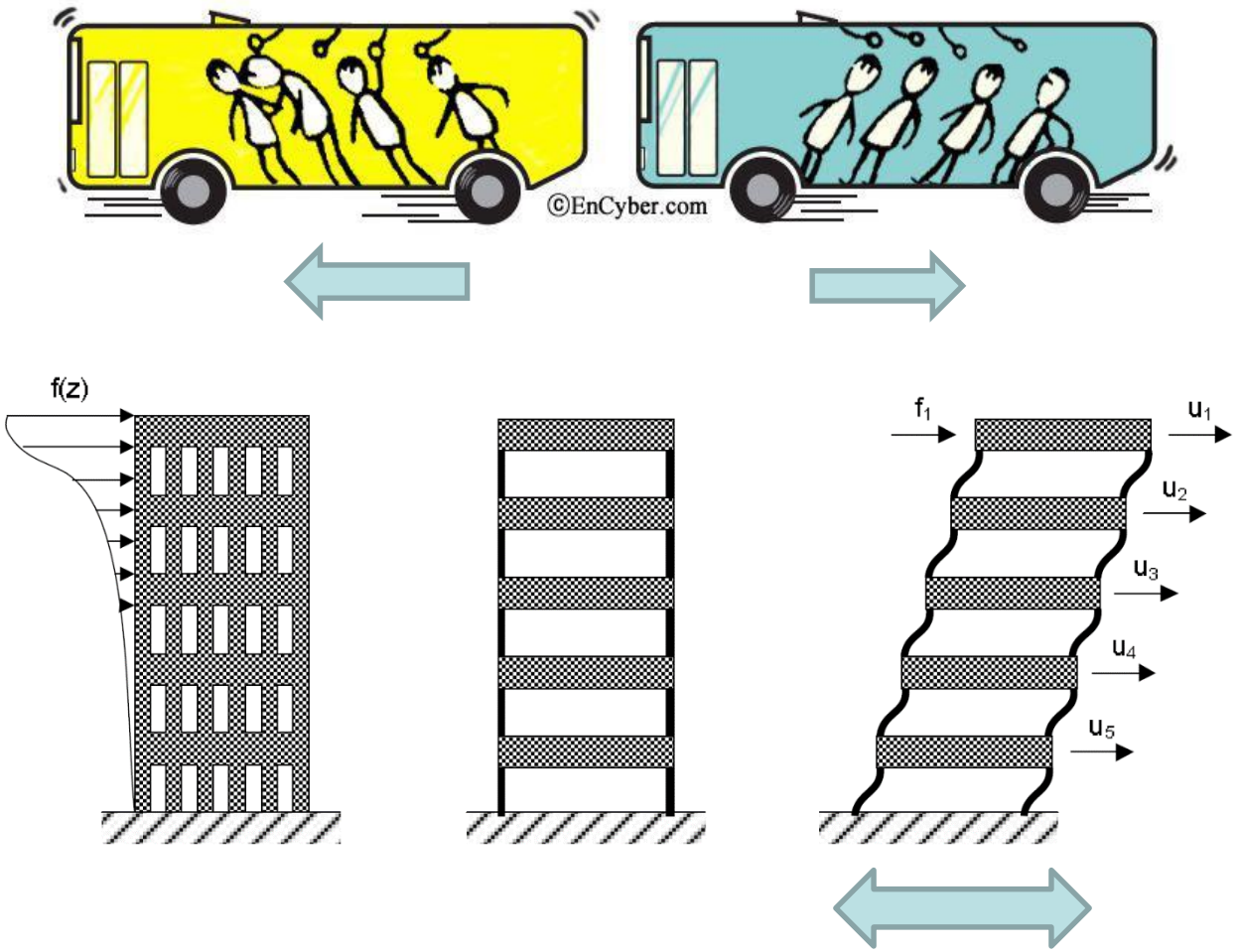

Variation of maximum accelerations of structures according to the dynamic period : 응답스펙트럼 (elastic response Spectrum)

Response spectrum – key feature of modern earthquake design codes

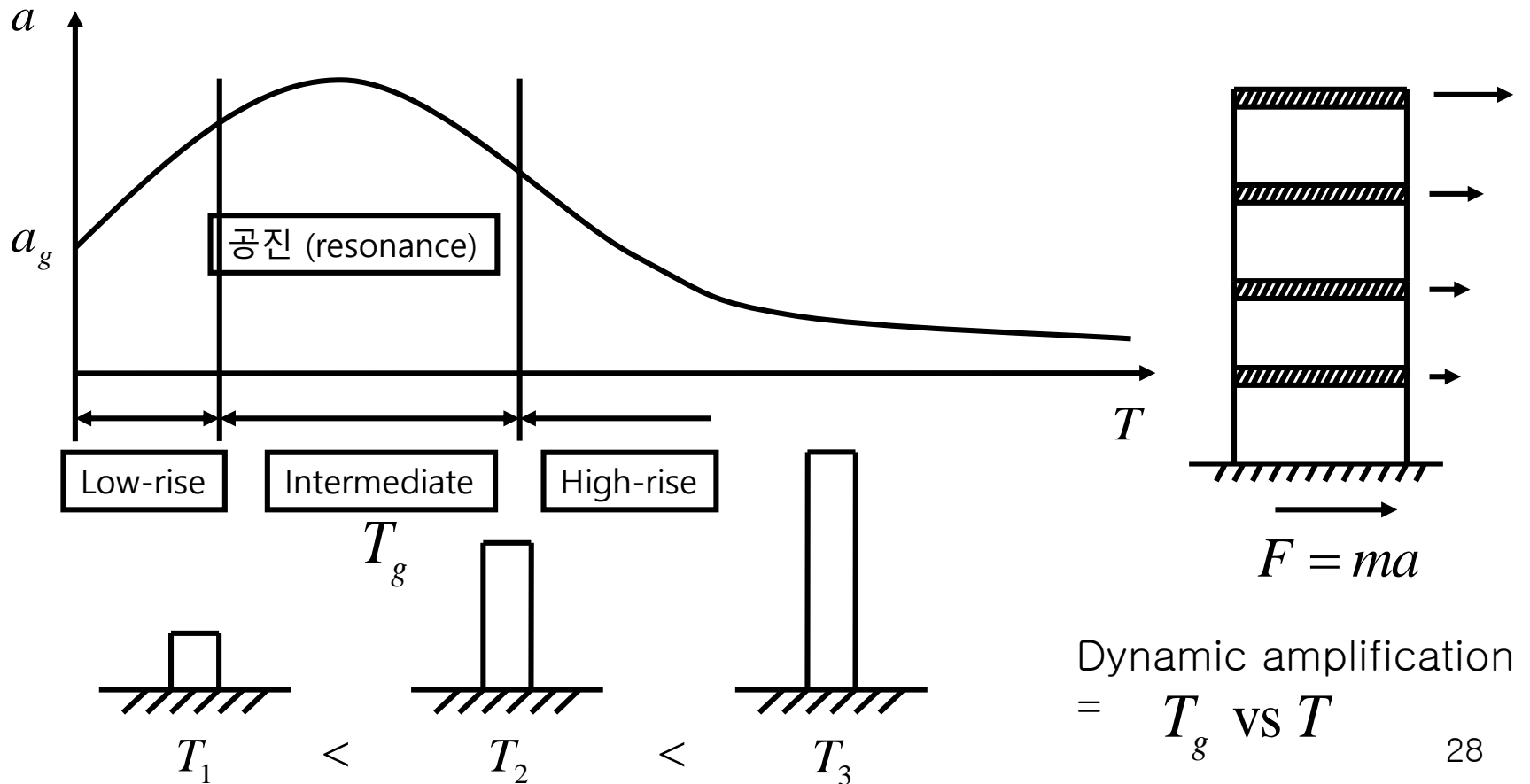

## 설계스펙트럼 (Design Response Spectrum)

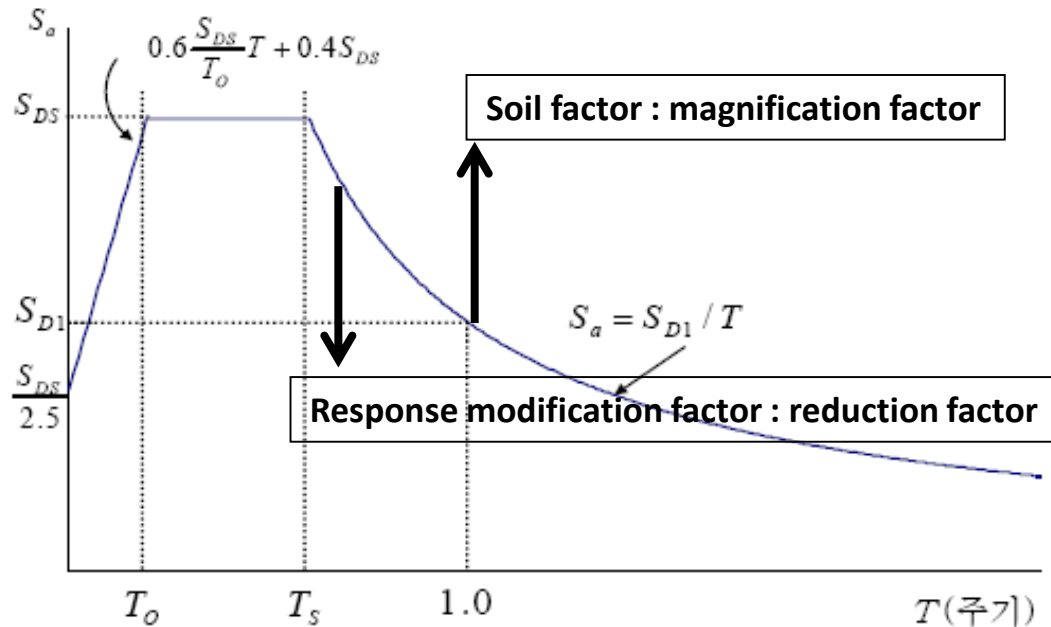

Response modification factor (반응수정계수) : decrease of earthquake load when ductility (inelastic deformation) of the structure is good. A reduction factor

Soil factor : increase of earthquake load for soft soil deposit

# Nature of EQ loading : EQ is not load but displacement

Thus, Eq load is not uniform, but varies with ductility of structures.

The purpose of EQ design is not to endure the force but to sustain the displacement.

$$m(a + a_g) + cv + ku = 0$$

$$ku \leq F$$

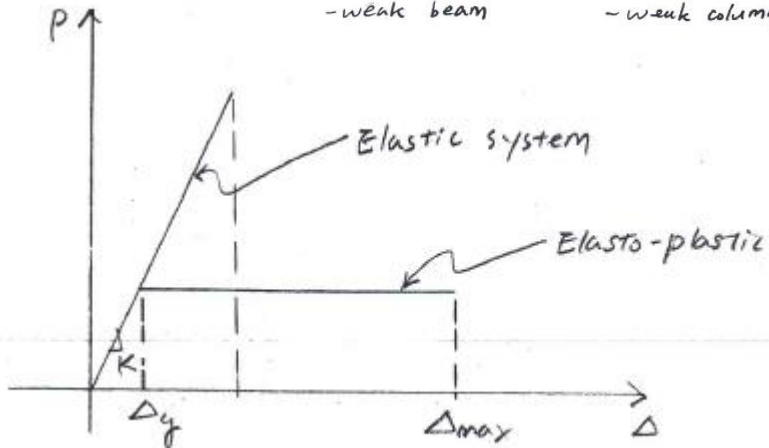
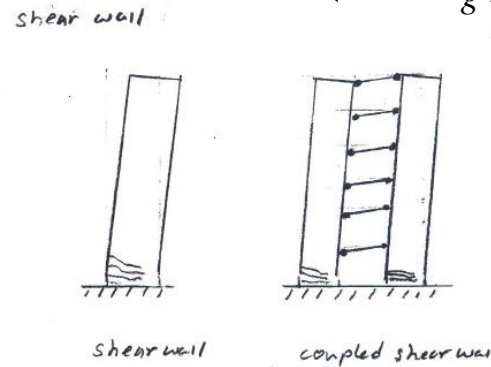
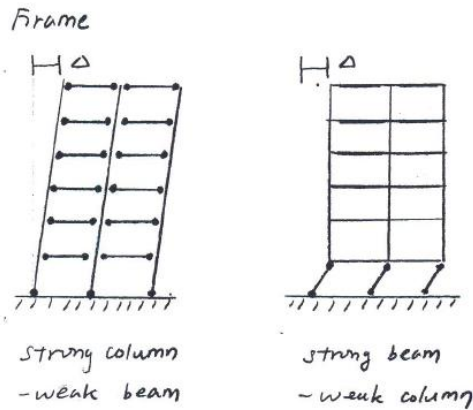

$$\mu = \Delta_{max} / \Delta_y$$

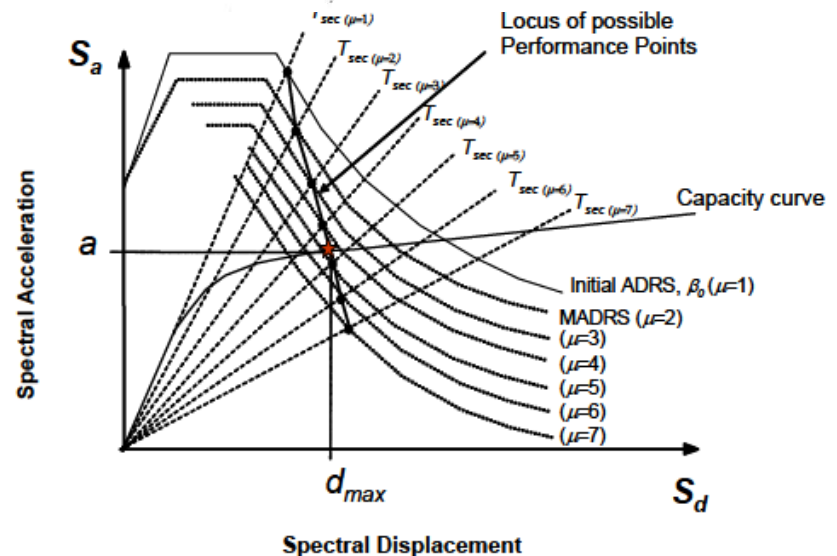

## 면진구조 (Base – Isolation)

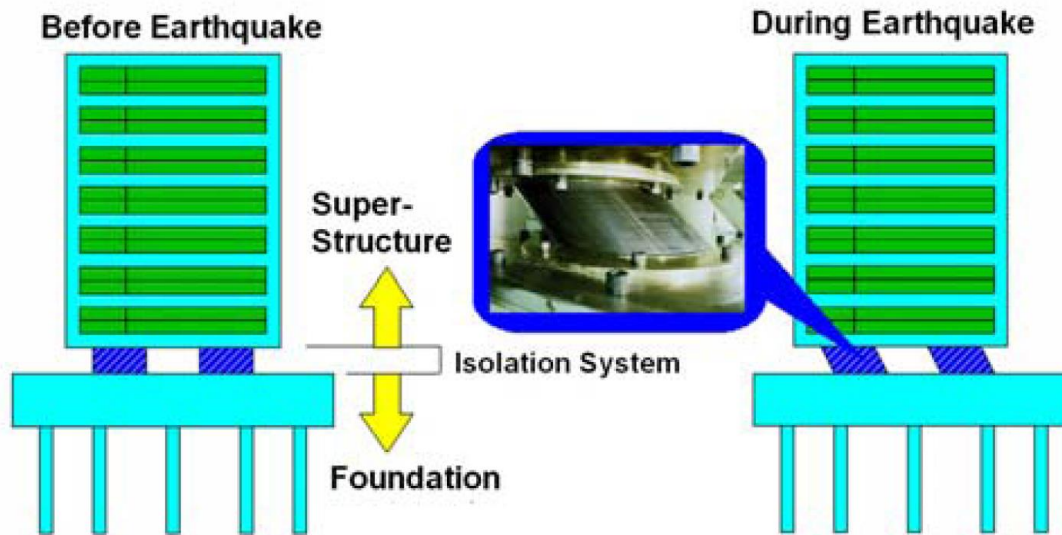

Fig. 17. Schematic diagram of a building with vibration isolation

$$m(a + a_g) + cv + ku = 0$$

By base-isolation,  $ku$  (resistance) is limited to very small value.

### 3. Design considerations

- Lessons from significant earthquakes led to the incorporation of more advanced codes for the construction of new buildings
- Big change in design codes
  - Old design codes : focused on increasing strength of structures
  - New design codes : increasing ductility capacity of structures

Earthquake occurrence and design codes in US

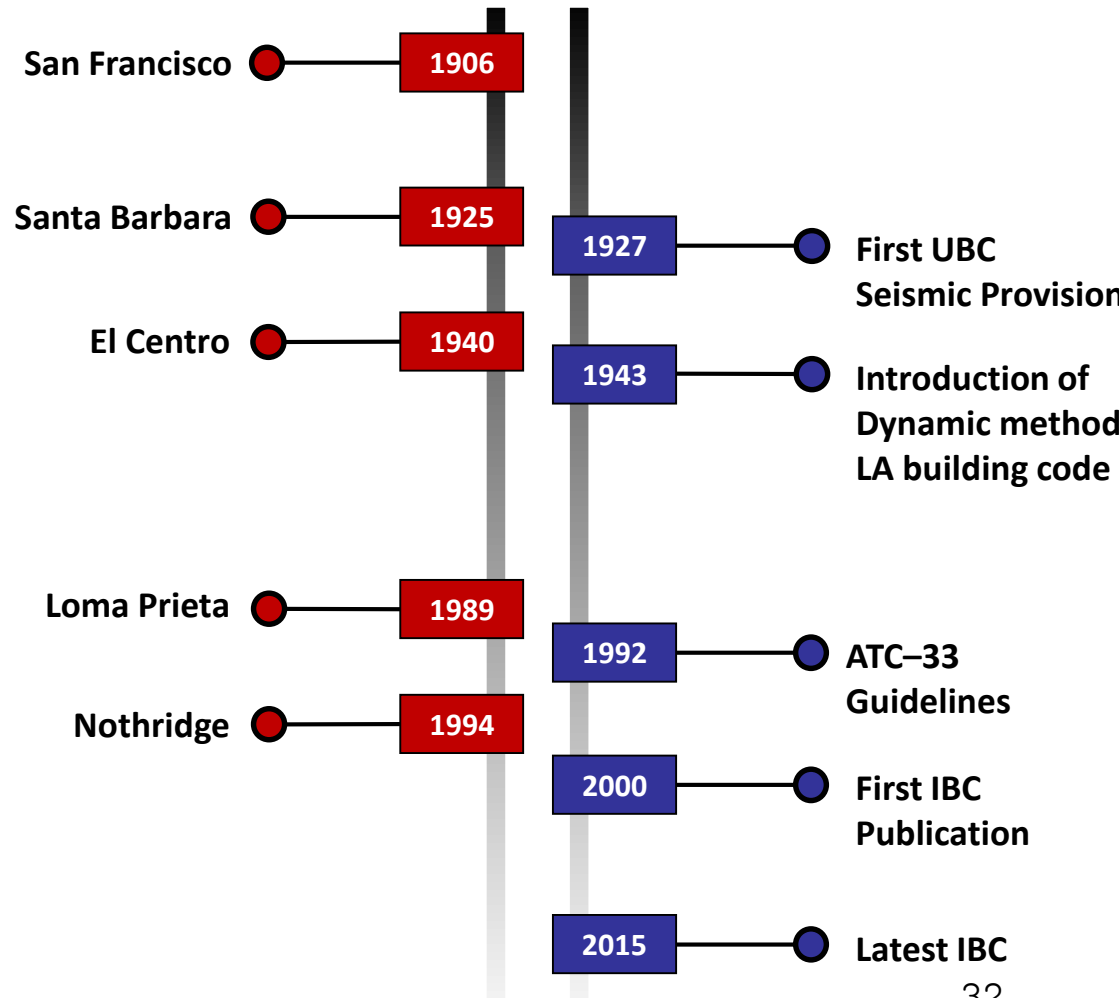



### 3. Design considerations

#### Mexico Earthquake

- Soil effect

Mexico city sitting on  
Soft soil deposit

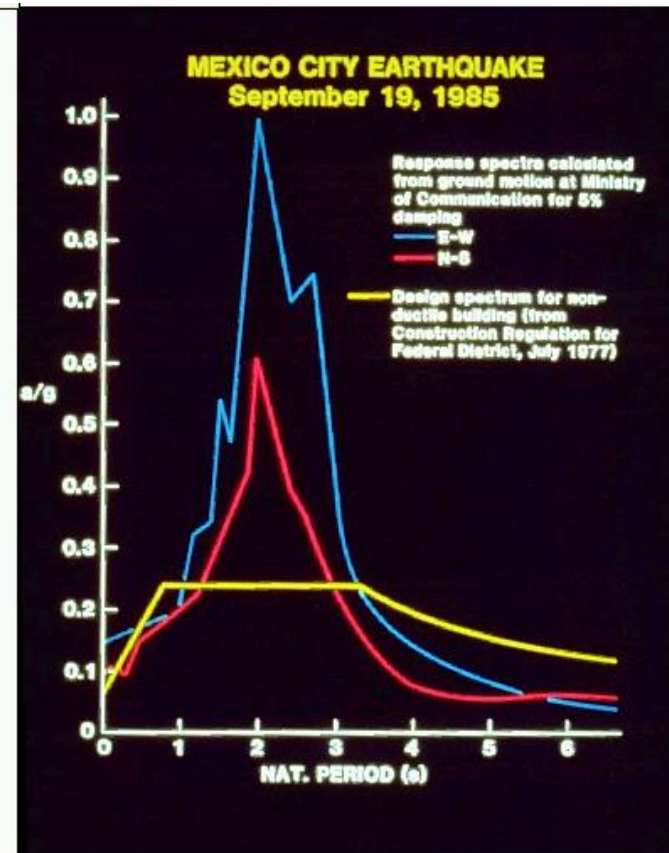
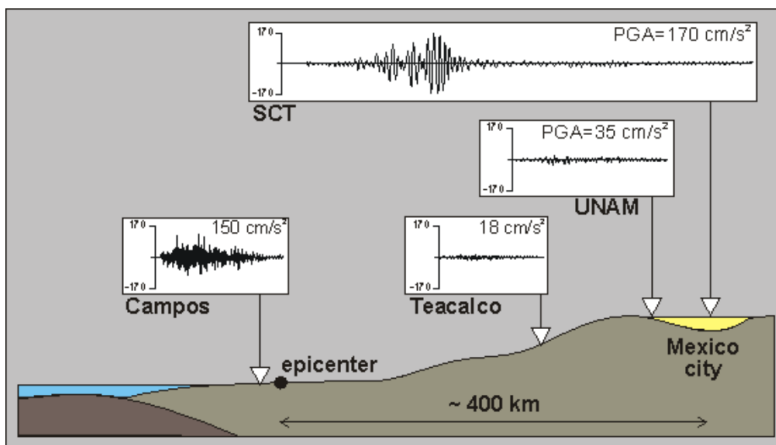

#### SCT Response Spectra

Prepared 10/85

East-west component response spectra for the SCT site, September 19, 1985 quake.

# Effect of soft soil Damage to High-rise buildings

-Resonance between soft soil deposit and high-rise buildings with long dynamic periods

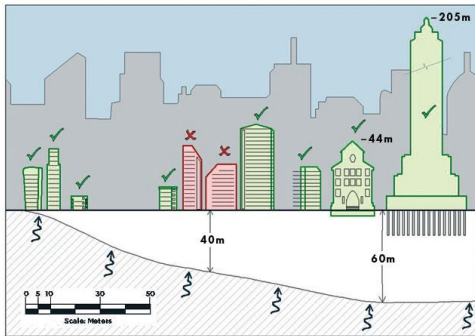

William Stone (NBS)

**Aerial view of Nuevo Leon Looking Northwest**

*Time and Location of Slide: 9/26/85*

Aerial view looking northwest of the collapsed Nuevo Leon Building. Hundreds died in the collapse.

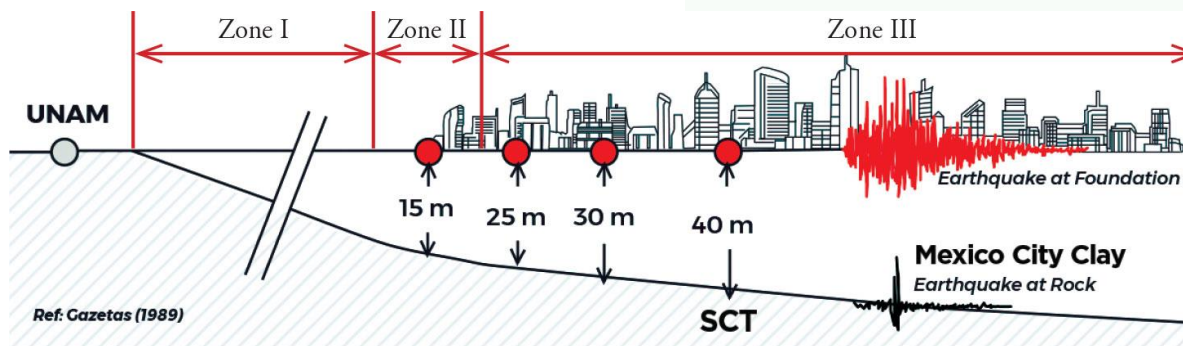



Edgar V. Leyendecker

## **Pino Suarez Towers Looking North**

*Time and Location of Slide: 9/27/85*

View looking north of the Pino Suarez Towers. Originally there were five structures at this site. Three central 21-story buildings and two flanking 14-story buildings. These government office towers were one of the few steel frame

# Collision between adjacent Buildings

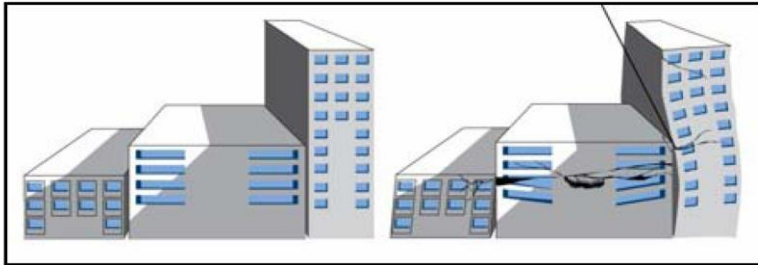

Fig. 12. Influence of the distance between adjacent buildings



William Stone (FBI)

## Aerial View of Continental Hotel

*Time and Location of Slide: 9/26/86*

Aerial view of the Continental Hotel, where different sections of the building collapsed when pounding or hammering occurred at nonstructural Joints. .



## Hammering of Unequal Height Buildings

*Prepared 10/85*

Building hammering was widespread in Mexico City. This slide depicts collision between two buildings of unequal height.



Chris Arnold

## **Pounding Damage**

*Time and Location of Slide: Hotel De Carlo, October 1, 1985*

Damage caused by pounding results in intermediate floor collapse. Note that in spite of severe structural distortion, much glass is unbroken.



# Soft story failure mechanism

- When the stiffness or strength of a story is relatively small, the majority of inelastic deformation can be concentrated to the story.



Chris Arnold

## Lower Floor Collapse

*Time and Location of Slide: Downtown Mexico City, October 1, 1985*

Collapse of a number of lower floors of a commercial building. Upper floors remain intact. Note open first floors contrasted to upper floor with the consequent stiffness differential probably leading to the failure.

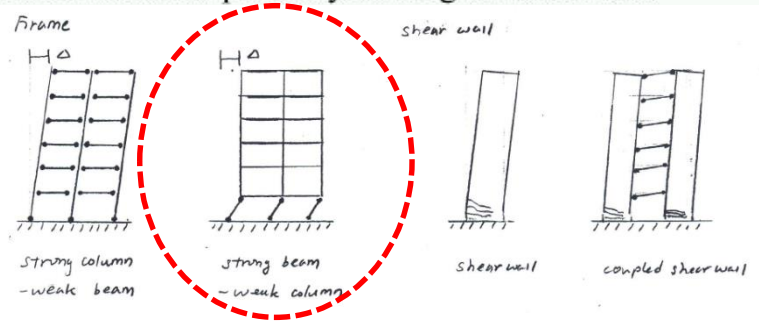
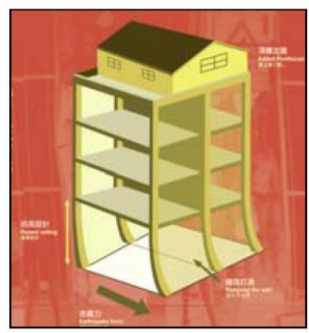

Fig. 7. Elevation of base floor, removal of partition wall, illegal penthouses on roof



# Effect of Irregular shapes

- when torsion occurs in a plan, the deformation of corner columns is significantly greater than those of interior columns.
- In this case, three-dimensional dynamic analysis should be performed to consider the torsional effect.
- Shape of buildings is a crucial factor for earthquake safety



## Building Distortion

*Time and Location of Slide: Downtown Mexico City, December 15, 1985*

Severe distortion of building that is triangular in plan to fit the site requirement at a multiple street intersection. Form of building results in the torsional behavior shown.

Chris Arnold

### Symmetry In Plan

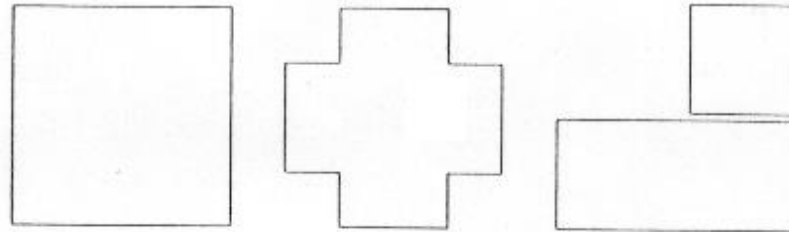

### Asymmetry in Plan

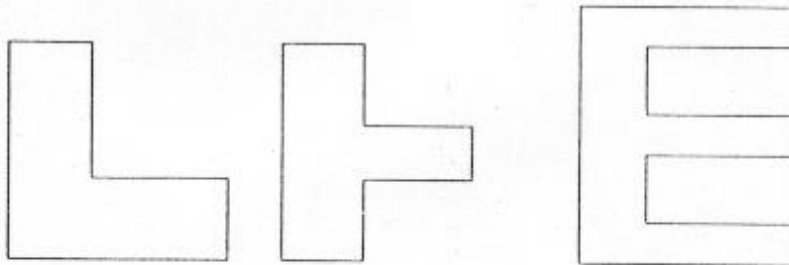

### Irregularity in Elevation

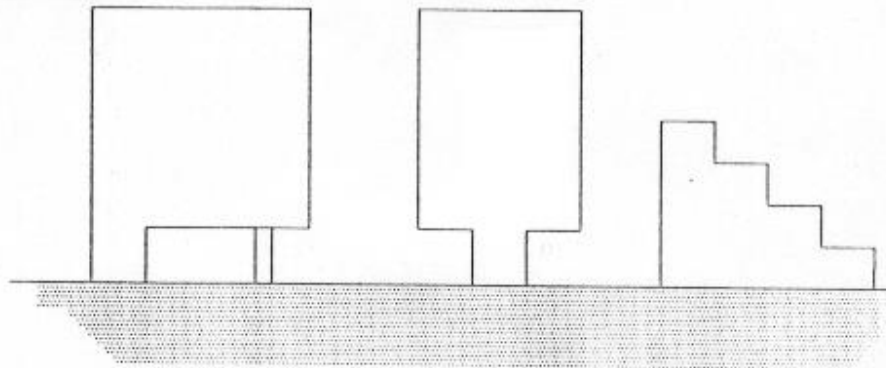

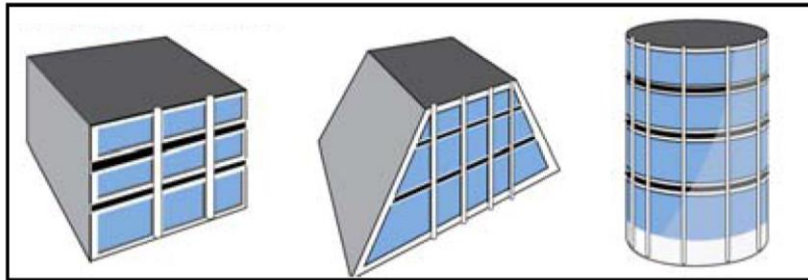

Fig. 9. Good elevation shape

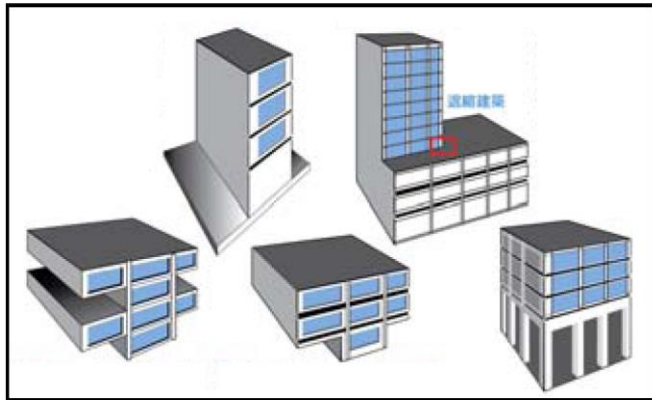

Fig. 10. Poor elevation shape

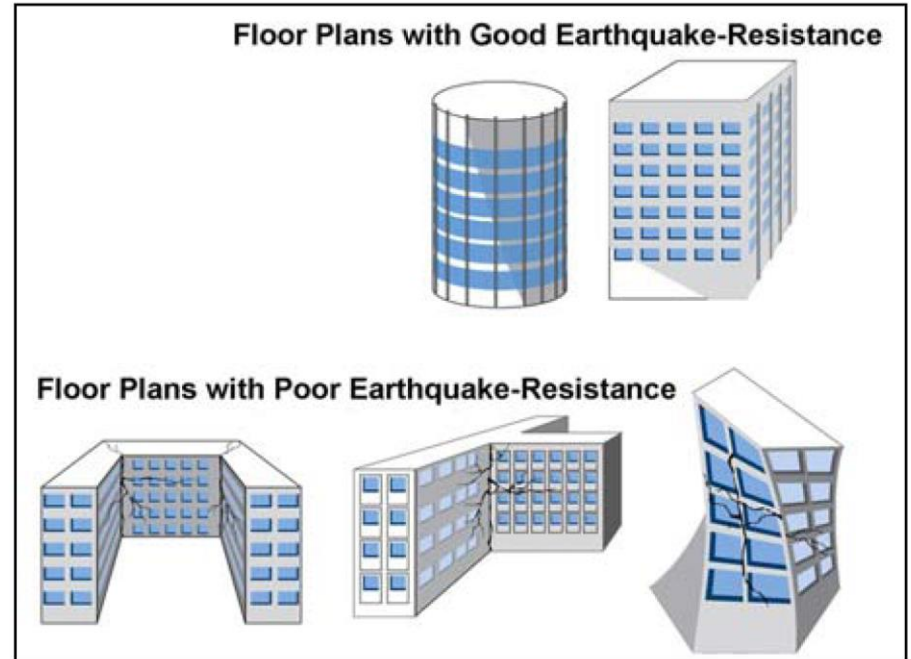
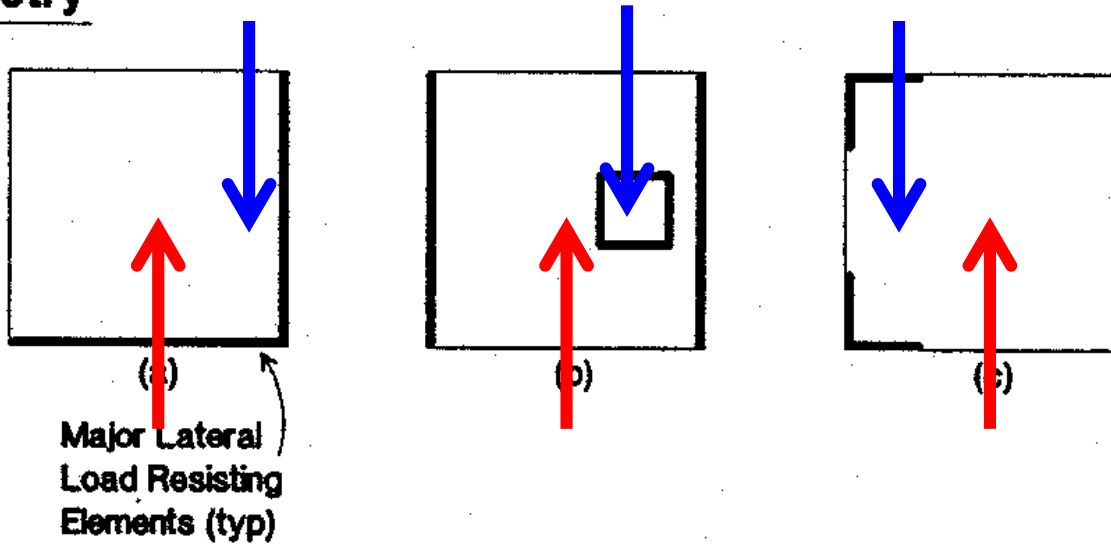

Fig. 11. Influence of plane shape on seismic resistance

Two crucial effects  
Additional force due to torsion  
Large deformation at corner columns

**Asymmetry**



**Symmetry**

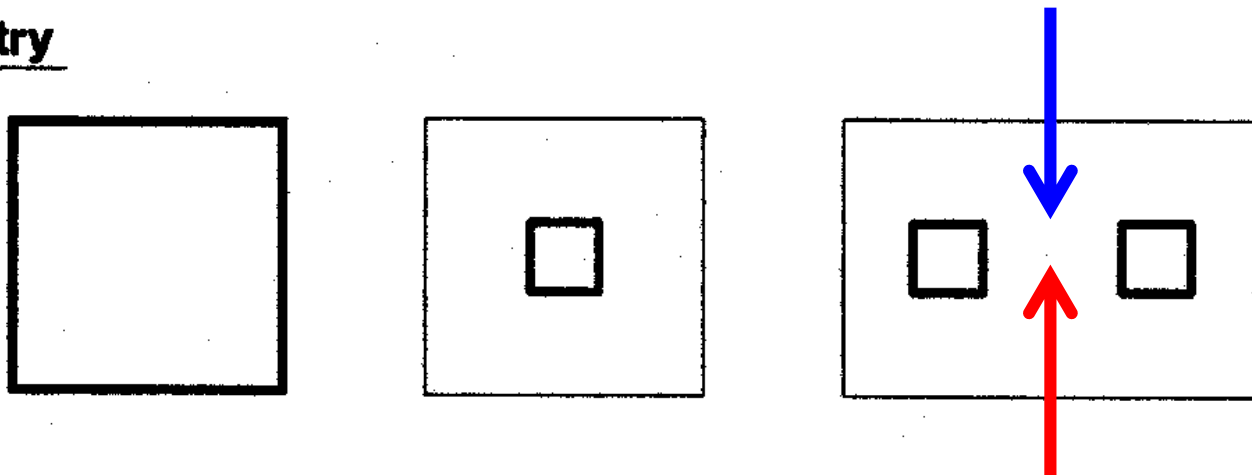

## Damage of nonstructural elements

- non-structural elements can cause more loss of lives and Economy than structural elements.



Chris Arnold

### **Infill Wall Damage**

*Time and Location of Slide: Downtown Mexico City, December 15, 1985*

Typical patterns of damage in unreinforced masonry infill wall. Note damage concentration towards bottom of walls.

## Damage of nonstructural elements

- secondary effect

Falling of nonstructure elements, fire can cause additional casualties and economic loss.

-Fixing nonstructural elements

가구를 비롯한 비구조재의  
적절한 고정이 필요



16. Prevent furniture from falling down during an earthquake

# Armenian Earthquake



## MAP OF THE AFFECTED AREA

This slide shows the portion of Armenia affected by the magnitude 6.8 earthquake of December 7, 1988. Cities that were most seriously impacted were **Spitak** (a city of about 25,000 inhabitants located in the epicentral region), **Leninakan** (a city of about 290,000 inhabitants located 40 km (24 miles) from the epicenter), **Kirovakan** (a city of about 225,000 located about 35 km (21 miles) from the epicenter), and **Yerevan** (the capital, with 1.2 million people, located about 100 km (60 miles) from the epicenter).

## Damage of masonry structures

- Unreinforced masonry
- Weakest structure under EQ.
- Heavy structure without connections

### Limitations in masonry structures

- height limitation
- connection between slab and brick wall
- cross walls are required.



Photographed by H. S. Lew; National Institute for Standards and Technology

### **DAMAGE TO LOAD BEARING STONE MASONRY WALL BUILDING IN SPITAK**

There are no ties between the floor planks and the wall. The ground shaking in the epicentral region was too great for this ineffective lateral force resisting system.



## Damage of Precast concrete structures

- Joints and details of PC  
조립식구조인 프리캐  
스트 콘크리트 구조는  
적절한 상세를 사용하  
지 않을 경우 붕괴를 초  
래할 수 있다.



Photographed by H. S. Lee, National Institute for Standards and Technology

### **DAMAGE TO 9-STORY PRECAST CONCRETE FRAME BUILDINGS IN LENINAKAN**

This slide shows collapsed and damaged nine-story precast concrete frame buildings in Leninakan. Poor diaphragm action due to lack of connections between the floor planks (flexicore precast floor panels) contributed to the failures.



## **FAILURE MECHANISMS OF PRECAST CONCRETE FRAME-PANEL BUILDINGS**

*Taken at 10:00 a.m. on December 24 in Leninakan*

shows the failure of floor planks of a building under construction which was to become the new building of the Polytechnic Institute. The floor planks, of lightweight concrete, hollow-core, and approximately 4 ft x 6 ft x 8 inches are simply supported on the beams over a 2 to 3 inch seat. There are no ties between the planks or between the planks and the beam reinforcement.



## PRECAST CONCRETE PANEL BUILDINGS

In the Soviet design of precast concrete panel buildings, virtually every precast interior wall is used as a load-bearing element having shear capacity. This design gives a stiff, redundant structure. Floors and roofs are precast concrete planks, but with positive infrastructural connections between the various elements.

In this slide, taken at noon in Leninakan on December 27, the performance of precast frame-panel and precast panel buildings can be compared. Many precast frame-panel buildings in Leninakan collapsed and are shown in the foreground, including one under construction. Precast panel buildings, in contrast, performed very well and are shown standing in the background. The difference in performance is due to the basic differences in their design as well as possibly to specific characteristics of the ground motion. Site amplification in the 1.0 to 2.5 second band was found in the strong motion records of the aftershock sequence recorded in Leninakan may have generated a greater load on the concrete frame-panel buildings.

# Loma Prieta Earthquake

LOMA PRIETA EARTHQUAKE  
SANTA CRUZ  
October 17, 1989



Surface Rupture

Damage of  
Nonstructural  
elements  
- Loss of human



## **San Francisco**

118 km (70 miles) from the Epicenter

Building officials and volunteers inspected more than 8,500 buildings; 260 were rated as "unsafe" and 1,400 as "limited entry." This slide shows the classic failure of an end wall of an unreinforced masonry building at Bluxome and Sixth Street. Six people were killed in a car outside of the building by the falling masonry.

# Soft story failure



Photographed by E.M. Leyendecker, USGS

## Marina District of San Francisco

The soft story weakened this structure. The level of ground shaking and the influence of the land fill on liquefaction and/or ground motion amplification were factors that also contributed to the damage.

Frame



strong column  
- weak beam

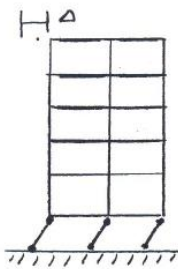

strong beam  
- weak column

shear wall



shear wall

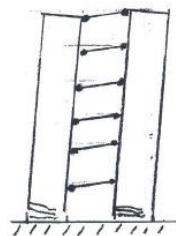

coupled shear wall



---

### **Detail of Failure: 1-880**

A view looking north at the west side of three type 2 bents. These bents included prestressing of the upper girders. In this particular mode of failure, only the east columns of the upper frames failed.



### **Close Up of Joint Failure: Embarcadero Freeway**

The reasons for damage to the Embarcadero Freeway are likely the same as the reasons for the damage to I-880, namely: 1) the structure was built prior to the adoption of modern seismic design criteria, and 2) both locations experienced large ground displacements. The damage correlated with that portion of the Embarcadero Freeway where a transition in the bent configuration occurred.



# Damage in Reinforced Concrete members



## Reinforcing Details: I-280

A close-up view of reinforcing details of failure zone in bent 51. Note anchorage failure of ties.

# Failure of Columns : lateral reinforcement

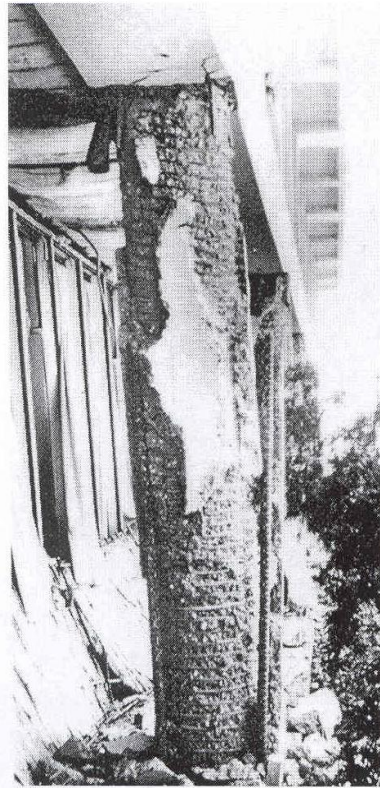

(b)

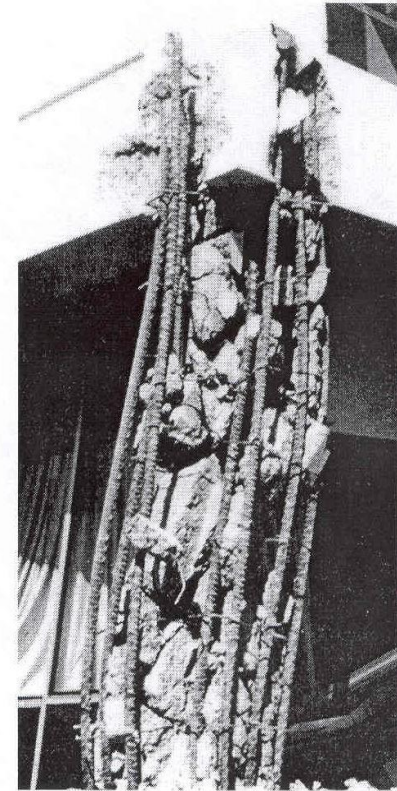

(c)

*Figure 10-18.* Damage to columns of the 4-story Olive View Hospital building during the February 9, 1971 San Fernando, California, earthquake. (From Ref. 10-38.) (a) A wing of the building showing approximately 2 ft drift in its first story. (b) Spirally reinforced concrete column in first story. (c) Tied rectangular corner column in first story.

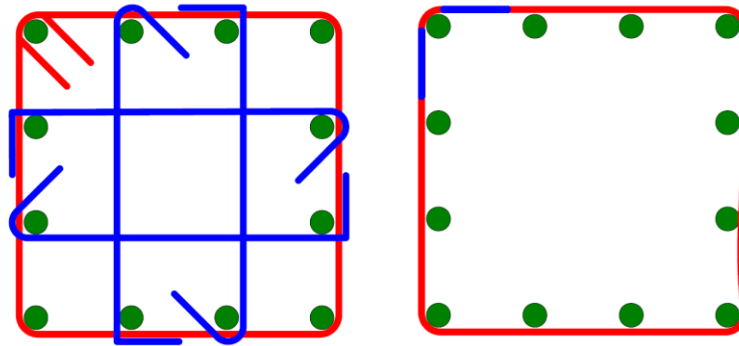

Fig. 15. Comparison on standard detail (left) and bad detail (right) regarding to hoops and tie bars.

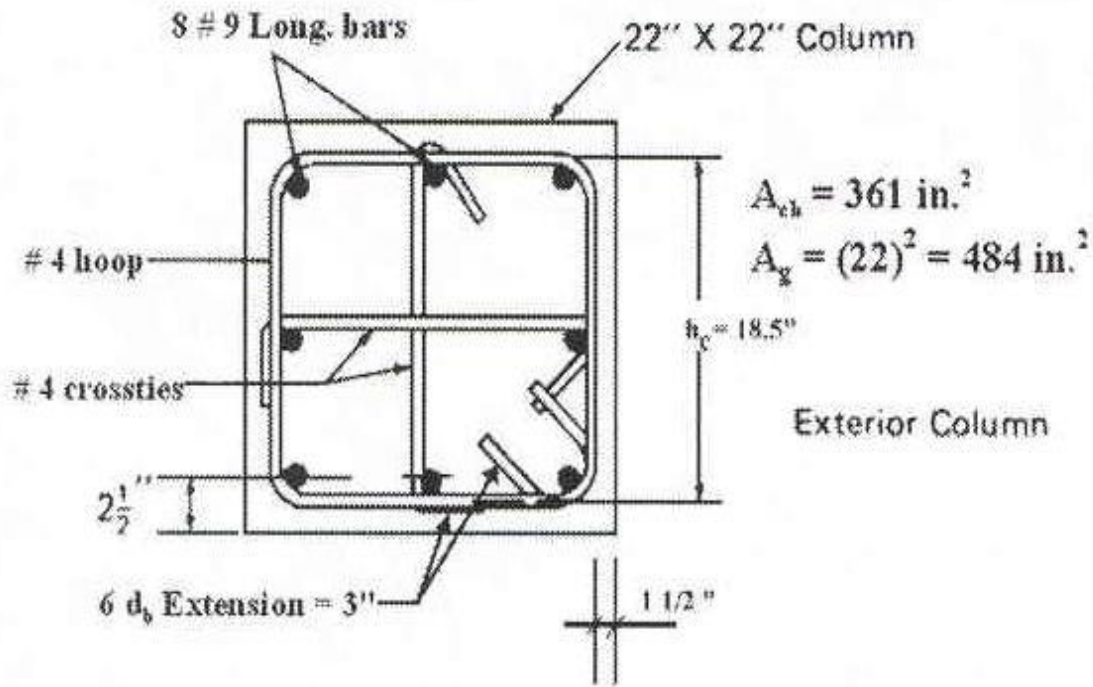
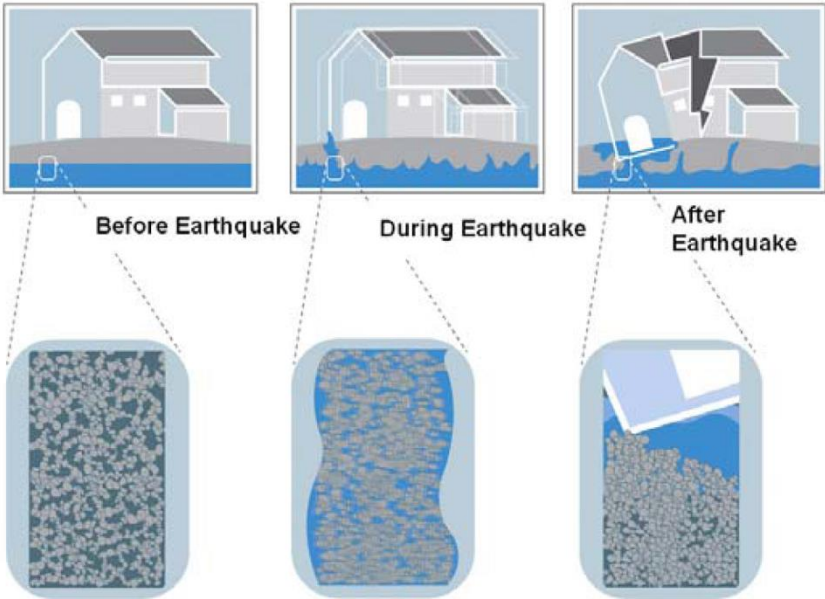

Figure 10-58. Detail of column transverse reinforcement.

# Soil liquefaction



out the ground failure zone - erupting onto the Marina Green (Slide 12) and s, through cracks in garage and basement floors, and next to buildings (Slide it near Cervantes). At most locations, ejected sand was dark gray in color, edged from the Bay bottom; however, at a few locations, ejected material was characteristics of nearby dune sand (Slide 14, taken at Scott and North Point

Fig. 4. Soil liquefaction process

## Nonstructural elements



---

### **Brick Facade Collapse**

While most of the buildings in the Marina district are wood-frame structures, many have an ornamental brick facade. During the strong ground shaking, quite a number of these facades became unattached from the building and crashed down onto the sidewalk or street.

## Soft story



**Slides 32 to 35:  
'Soft-Story' Building Deformation**

Soft story



### **Nonductile Concrete Buildings**

*Another type of vulnerable construction is the nonductile reinforced concrete*

# Strong column- Weak beam

- 주요부재이면서, 취성 거동을 나타내는 기둥 보다는 보에 소성힌지가 발생되도록 유도



**Nonductile Concrete Buildings**

Frame



strong column  
- weak beam



strong beam  
- weak column

shear wall



shear wall

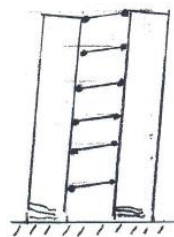

coupled shear wall

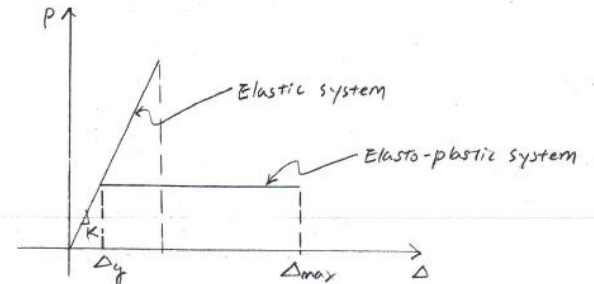



## Fracture of steel in welded connection

- 재료적으로 연성인 강 구조의 취약한 부분은 접합부. 특히 용접접합



Steel Buildings

# 1994 Northridge Earthquake (미국)

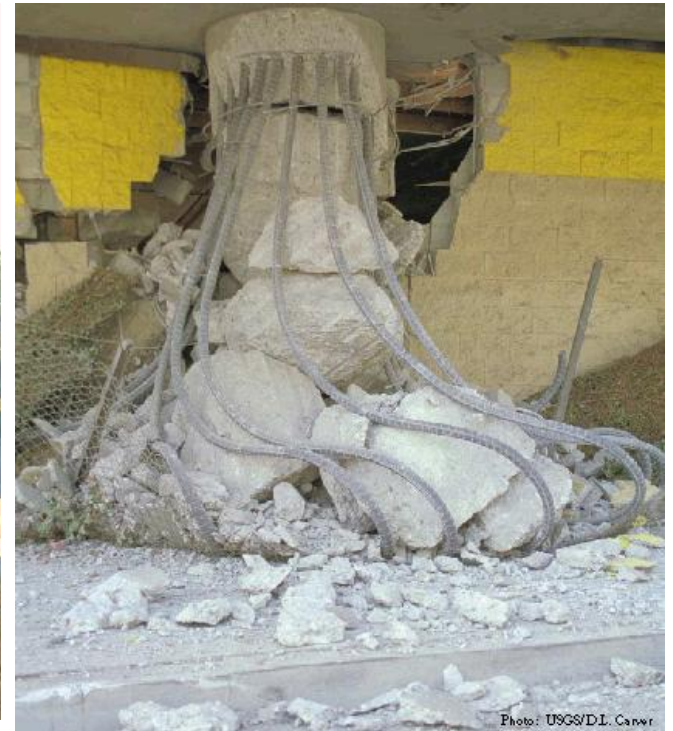

Failure of bridge columns caused by the lack of lateral reinforcement

# Kobe earthquake

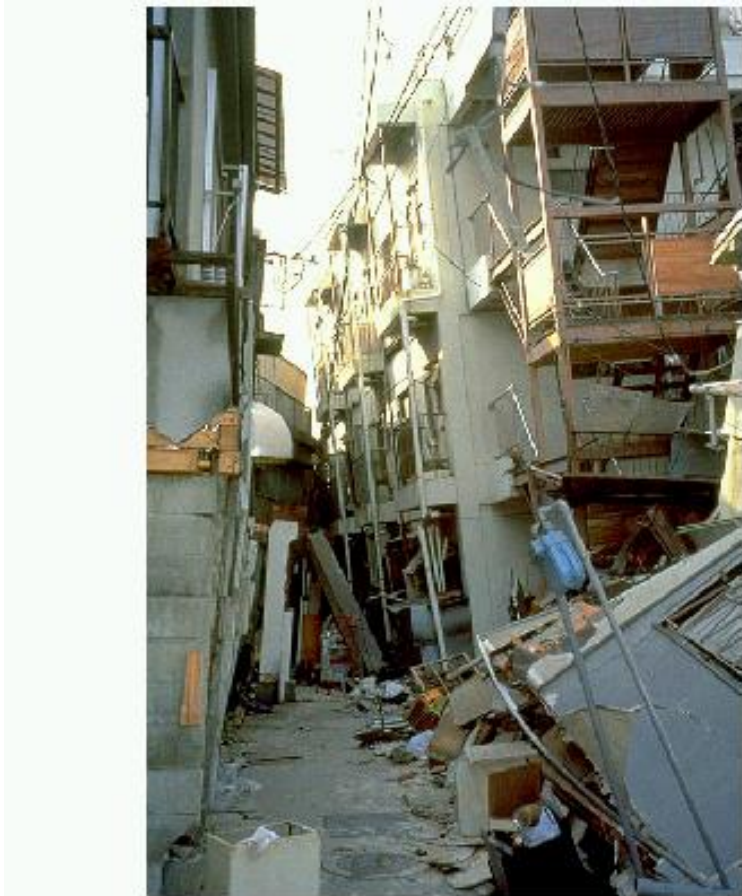

Collapse of a typical multi-story apartment building in Nishinomiya.



10년전인 1995년 1월 17일 엇가락처럼 휘어진 한신고속도로 (왼쪽)가 새로운 내진 공법으로 1년 8개월여의 공사끝에 말끔히 복구돼 차량들이 오가고 있다. /일본 산케이신문제공

## Irregular structure



### **Slide 16-17:**

A number of buildings built on city-block corners sustained partial collapse at the corner of the building, or failed completely.

## Soft story



### Slide 18-20:

Partial or full collapse of a single story in buildings was the common failure for most of the larger buildings. The particular story that sustained partial or full collapse varied from building to building. First-story failure was more common than mid-level or upper-story collapse.

New earthquake

Design code

- Requirement of ductility details

- 연성상세를 요구한  
1975년 이후 신축된 구조물은 큰 손상을 받지 않았다.



Severe damage to relatively modern hotel structure in downtown Kobe. While the majority of partial or complete collapses appear to be older, reinforced-concrete buildings (pre-1975), severe structural damage was also observed for buildings of steel or composite construction.

Old earthquake  
codes :  
Strength  
requirement



### **Pre-1971 Concrete Frame Buildings**

First story collapse of non-ductile concrete frame building. Collapse of soft first story concrete frame buildings were common.



## Pre-1971 Concrete Frame Buildings

Collapse of another soft first story non-ductile concrete frame.





### **Newer Concrete Frames**

Five-year-old 6-story concrete frame with garage level collapse. This was an exception to the rule of good performance of newer concrete buildings. Note, however, that there were ductile detailing problems in the columns and the building had a severe vertical (soft-story) irregularity as well as a plan irregularity causing torsion.



## **Steel Frame Buildings**

Mid-rise steel braced frame parking garages. There were many similarly damaged garages utilizing this construction type, common in Japan. As in the U.S., braced frames such as these suffered damage due to lack of connection strength and ductility. However, collapses were rare.



## **Steel Frame Buildings**

Older steel frame parking garage with bracing in one direction and moment frames in the other. The moment frames experienced fracture at the welded flange connections with cracking extending into the web.

# 1995 Kobe Earthquake (일본)



Fracture of steel tube column with thick plates

# 2008 Sichuan earthquake

Big EQ. in China since 1976 Tangsan EQ.  
Intraplate EQ.

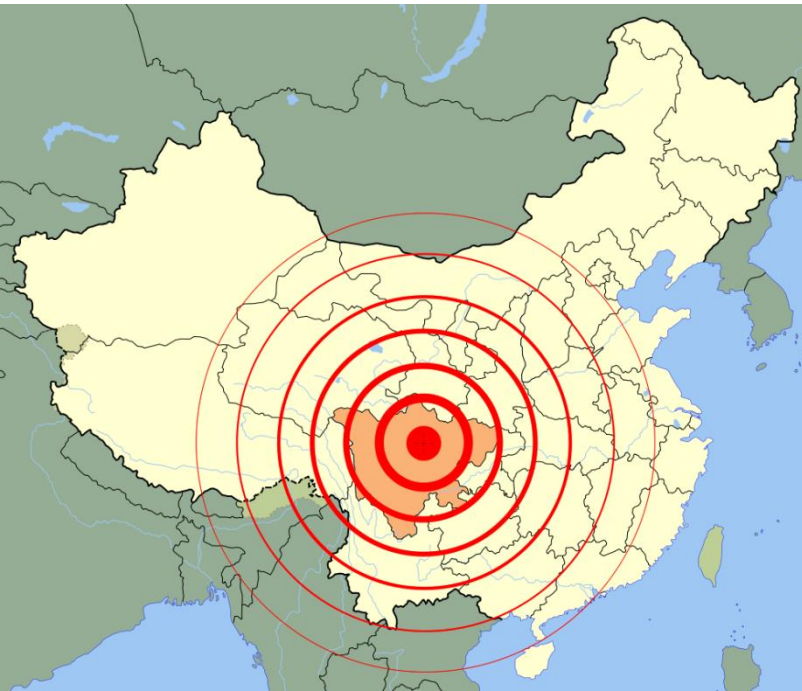

Date	May 12, 2008
Magnitude	8.0 M
Depth	6 km (4 mi)
Epicenter	31.021°N 103.367°E
Areas affected	China
Total damage	Building and infrastructure damage, landslide, formation of landslide dams <b><i>almost 80% of buildings destroyed</i></b>
Max. intensity	XI
Casualties	69,195 dead (21st deadliest earthquake of all time) 18,392 missing

## 2008 Sichuan earthquake in numbers

**87,150**

Number of people killed and missing

**4,800,000**

Number of people left homeless

**7.9M**

Strongest earthquake to hit China since 1950

**\$137.5<sub>bn</sub>**

Money spent on rebuilding the affected areas

**1,700<sub>km</sub>**

Distance from epicentre to Shanghai, where tremors were felt

## Ten costliest earthquakes, 1900-2013

Estimated direct loss at time of event (USD, Purchasing Power Parity adjusted)

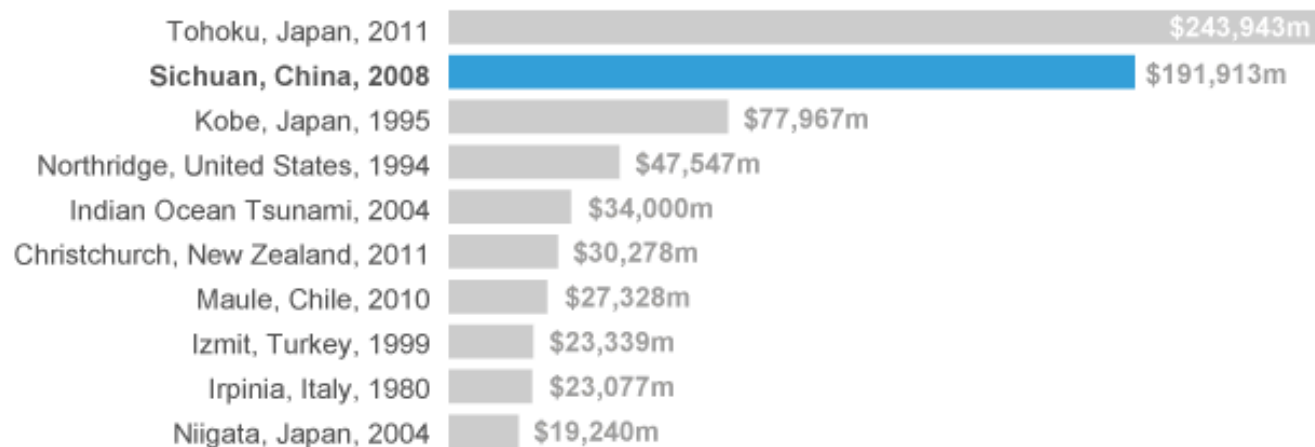

Source: CATDAT Damaging Earthquake Database, v5.1800, 26.03.2013

- Earthquakes in daytime
- Collapse of schools and hospitals.



School collapse

Hualien Earthquake (Mw = 6.4), Taiwan, 2018-02-04





Hualien Earthquake (Mw = 6.4), Taiwan, 2018-02-04



Hualien Earthquake (Mw = 6.4), Taiwan, 2018-02-04



# 4. Earthquake in Korean Peninsular

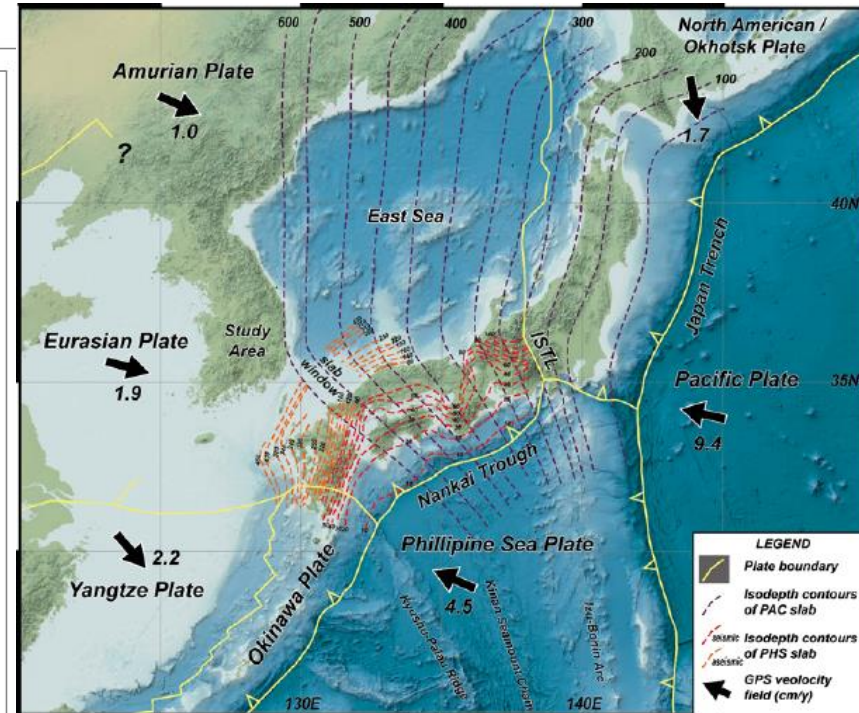
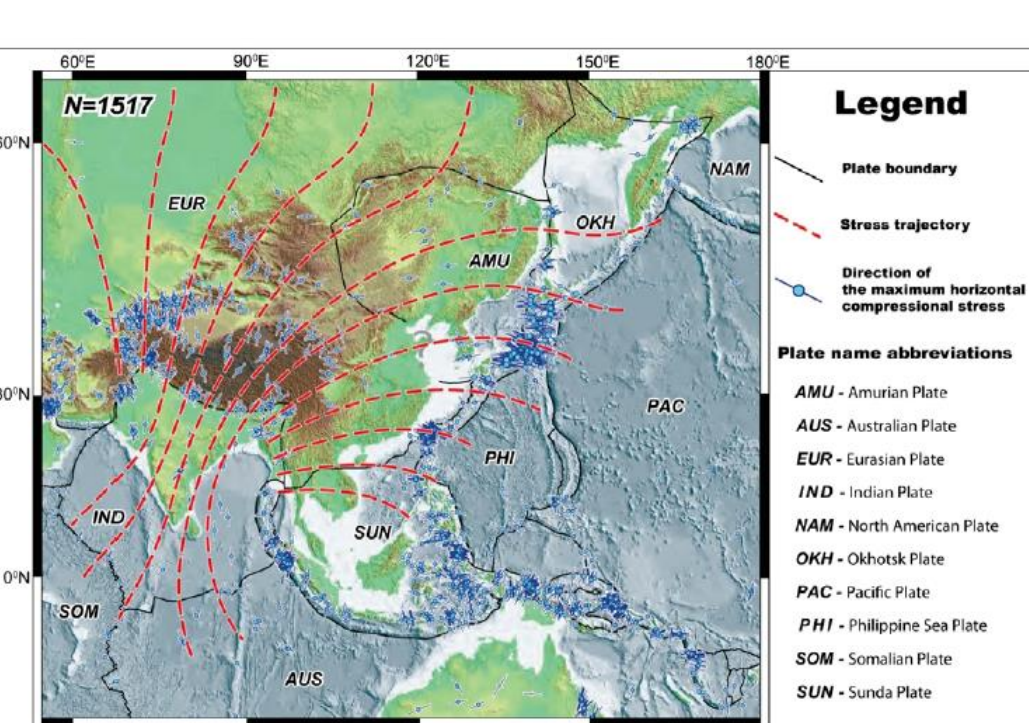

# Historical earthquakes in Korea (AD 2 ~ 1904)

## 주요 피해역사지진 (779년 3월)

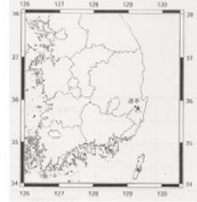
	C	D	E	F	G	H	I	J	K	L	M	N	O	P	R
85	혜공왕 6년 11월	770-11	35.9	129.2									서울에 지진이 있었다. (증) 신라-서울(京都)에 지진이 일어났다	삼국사기등 역사서에 나타난 피해	
86	혜공왕 13년 3월	777-03	35.9	129.2								서울에 지진이 있었다. (증) 신라-지진이 일어났는데, 4월에도 또한 그와 같았다			
87	혜공왕 13년 4월	777-04	35.9	129.2											
88	혜공왕 15년 3월	779-03	35.9	129.2		8	35.8	129.3					서울에 지진이 발생하여 민가가 무너지고 사망자가 백여명이 되었다. (증) 신라-서울(京都)에 지진이 일어나서 민가(民家)가 파괴되고 1백여 명이 죽었다.	100 people death Aftershock EQ for several days Liquefaction이 발생	
															
89															
90	원성왕 3년 2월	787-02	35.9	129.2									서울에 지진이 있었다. (증) 신라-서울(京都)에 지진이 일어났다		
91	원성왕 7년 11월	791-11	35.9	129.2									서울에 지진이 있었다. (증) 신라-서울(京都)에 지진이 일어났다		
92	원성왕 10년 2월	794-02	35.9	129.2									지진이 있었다. (증) 신라-지진이 일어났다.	779. 3. (혜공왕) 서울에 지진이 발생하여 민가가 무너지고 사망자가 백여명이 되었다. (증) 신라-서울(京都)에 지진이 일어나서 민가(民家)가 파괴되고 1백여 명이 죽었다.	
93	애장왕 3년 7월	802-07	35.9	129.2									지진이 있었다. (증) 신라-지진이 일어났다.		
94	애장왕 4년 10월	803-10	35.9	129.2									지진이 있었다. (증) 신라-지진이 일어났다.		
95	애장왕 6년 11월	805-11	35.9	129.2									지진이 있었다. (증) 신라-지진이 일어났다.		
96	흥덕왕 원년 경월	826-01											지진이 있었다. (증) 신라-지진이 일어났다.		
97	흥덕왕 6년 1월	831-01	35.9	129.2									지진이 있었다. (증) 신라-지진이 일어났다.		
98	문성 1. 5	839-05											지진이 있었다. (증) 신라-지진이 일어났다.		
99	문성 6	844											지진이 있었다. (증) 신라-지진이 일어났는데, 소리가 비락치는 것 같았다		
100	경문왕 10년 4월	870-04	35.9	129.2									서울에 지진이 있었다. (증) 신라-서울(京都)에 지진이 일어났다		
101	경문왕 12년 4월	872-04	35.9	129.2									서울에 지진이 있었다. (증) 신라-서울(京都)에 지진이 일어났다 서울과 동쪽지방에 지진이 있었다.		

# Inland earthquakes greater than M=4.5 in Korea

- 쌍계사 지진 (1936) M=5.1
- **평양 지진 (1952) M=6.2**
- 속리산 지진 (1978) M=5.2
- 흥성 지진 (1978) M=5.0
- 삭주 지진 (1980) M=5.0
- 포항 지진 (1981) M=5.0
- 사리원 지진 (1982) M=5.1
- 울진 지진 (1982) M=5.0
- 울산 지진 (1994) M=4.6
- 울산 지진 (1994) M=4.5
- 홍도 지진 (1994) M=4.9
- 영월 지진 (1996) M=4.5
- 백령도지진 (2003) M=5.0
- 울진지진 (2004) M=5.2
- **경주지진 (2016) M = 5.8**
- **포항지진 (2017) M = 5.4**

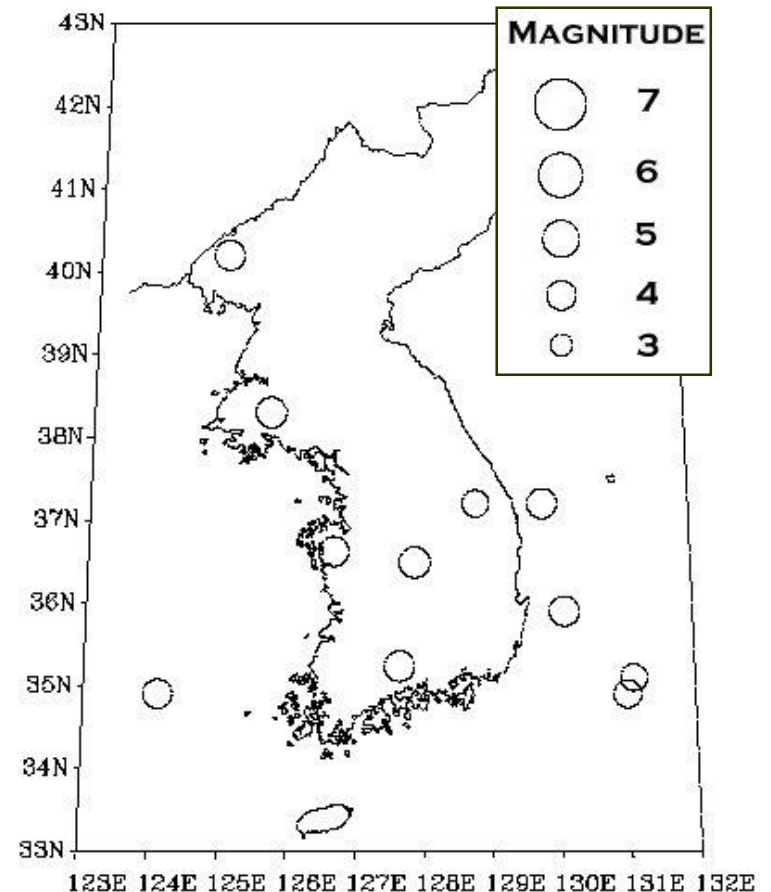

# PyeongYang Earthquake in 1952/3/19

- largest EQ since 1905
- It occurred during Korean War
- 한반도 지진위험도 평가에 중요한 의미를 가지므로, 관측기록에 기반한 지진원 특성의 정량화가 필수적임

- measurements

Rustanovich et al.(1963): M=6.3

中国国家地震局科技情報中心(1987): Ms=6.5

李裕澈(2001): M=6.5

Ishikawa et al.(2008): Md=6.5

USGS : Mw=6.3

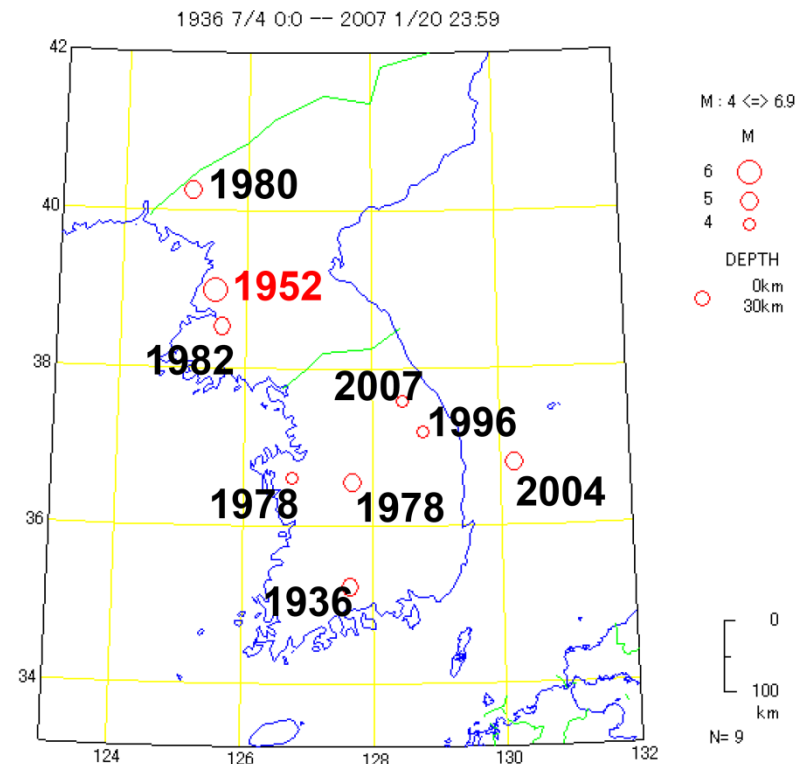

(Ishikawa et al., 2008)

# Hongsung EQ, 1975, M= 5.0



# Kyungju EQ (2016. 09. 12) M= 5.8

The first (pre-) shock: **M<sub>L</sub> 5.2, 19:44**  
The main shock: **M<sub>L</sub> 5.8, 20:32**  
Focal depth: **13km (relatively deep)**

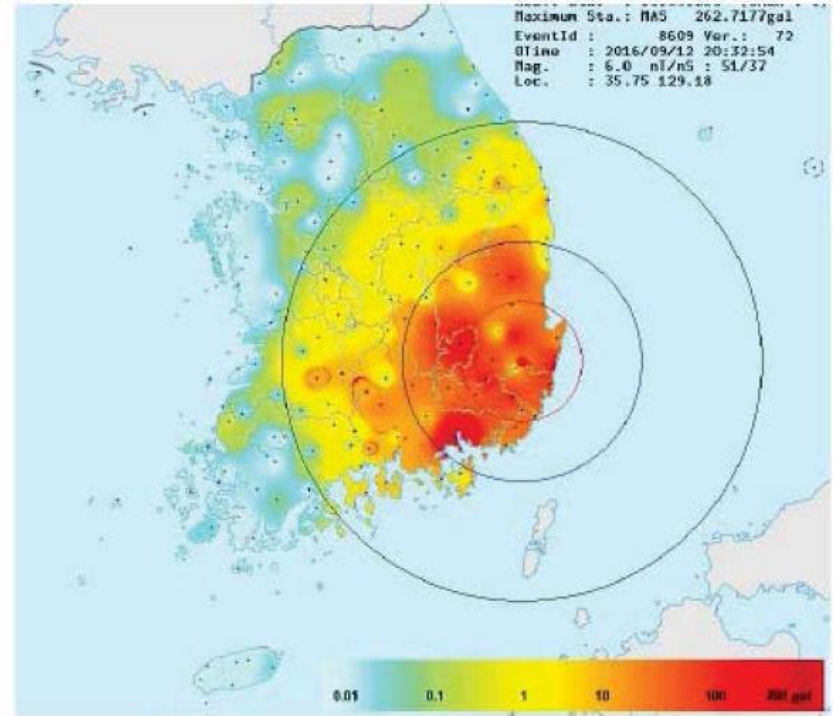





Show window shattered



Unreinforced block wall fallen down



Typical corner cracking at opening



Failure in an already poor (non-engineered) construction

*Steel Structures & Seismic Design Lab, Dept. of Arch and Arch Engrg, SNU*



Damage observed in a 3-story RC Building (Ulju, Ulsan)\_ ceiling and brick wall failure



*Steel Structures & Seismic Design Lab, Dept. of Arch and Arch Engrg, SNU*

## The most impressive failure mode\_ “short-column” shear failure



One of the well-known seismic failure modes observed in a Buddhist temple: so called “short-column” shear failure  
Never imagined to see....

*Steel Structures & Seismic Design Lab, Dept. of Arch and Arch Engrg, SNU*

# Pohang EQ (2017. 11) M= 5.4

Epicentral distance is only a few kilometers



# Pohang EQ (2017. 11) M= 5.4

**Epicentral distance is only a few kilometers**



## 11·15 포항지진 피해 현황

피해 주민	30%	전체 51만9581명 중 15만8484명
피해 가구	26%	전체 21만3767가구 중 5만5095가구
이재민	2390명	956가구·지진 당시
직·간접 피해액	3324억원	한국은행 추산
유·무형 피해액	14조원	포항시 추산
관광업 피해	30%▼	핵심상권 매출
부동산 피해	50%▼ 20%▼	거래량 가치
외상후 스트레스	10명 중 4명	시민 10명 중 4명
인구 감소	4834명	지진 후 19개월·0.9%

# Pohang EQ (2017. 11) M= 5.4



**Heunghae Elementary School**

**Short column effect  
By masonry wall**



# Piloti column : soft story mechanism

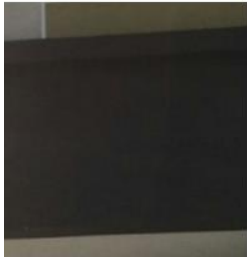
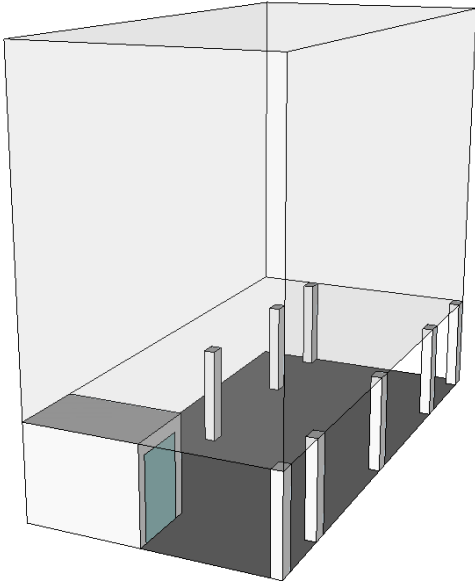

온라인 커뮤니티



## School damage

기둥, 내력벽 손상 / 피복탈락 및 균열

경북 포항 00초등학교



초등학교 지진 피해  
(포항=연합뉴스) 15일 발생한 지진으로 경북 포항 한 초등학교 건물 기둥과 벽 일부가 금이 가거나 부서졌다.  
2017.11.15 [독자 제공=연합뉴스]



# School damage

비구조재 손상 및 탈락 / 땅꺼짐 현상



독자 제공



## Non-structural damage



【포항=뉴스시스】박준 기자 = 15일 오후 2시29분께 경북 포항시 북구 북쪽 6km 지역에서 규모 5.5의 지진이 발생해 도로가 갈라지고 건물 외벽이 무너지는 등 피해가 속출했다. 2017.11.15june@newsis.com



15일 포항에서 발생한 지진으로 건물 외벽이 도로에 널부러져 있다. 포항에서는 한동대학교 외벽이 무너지는 등 피해가 잇따랐다. 사진=구독자 제보

# Pohang EQ (2017. 11) M= 5.4



**Falling of ceiling**



**Falling of masonry wall**

# Non-structural damage

[현장포토] 포항지진피해, 마트에서 물건이 '우수수' 떨어져

기사입력 2017-11-15 16:25



↑ 포항지진피해/사진=MIN 시찰자 제공

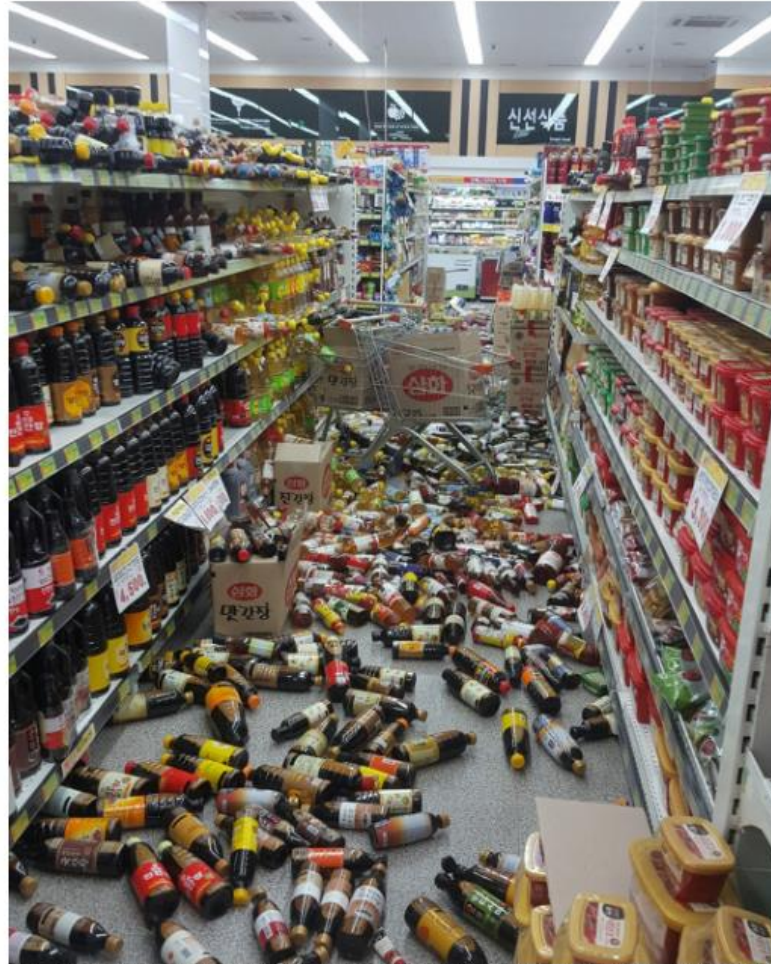

15일 오후 2시 29분께 경북 포항시 북구 북쪽 6km 지점에서 규모 5.4 지진이 발생했다. 포항시 두호동의 한 마트의 물건이 바닥에 쏟아져 있다 (사진=연합뉴스)

# Earthquake in Seoul Area

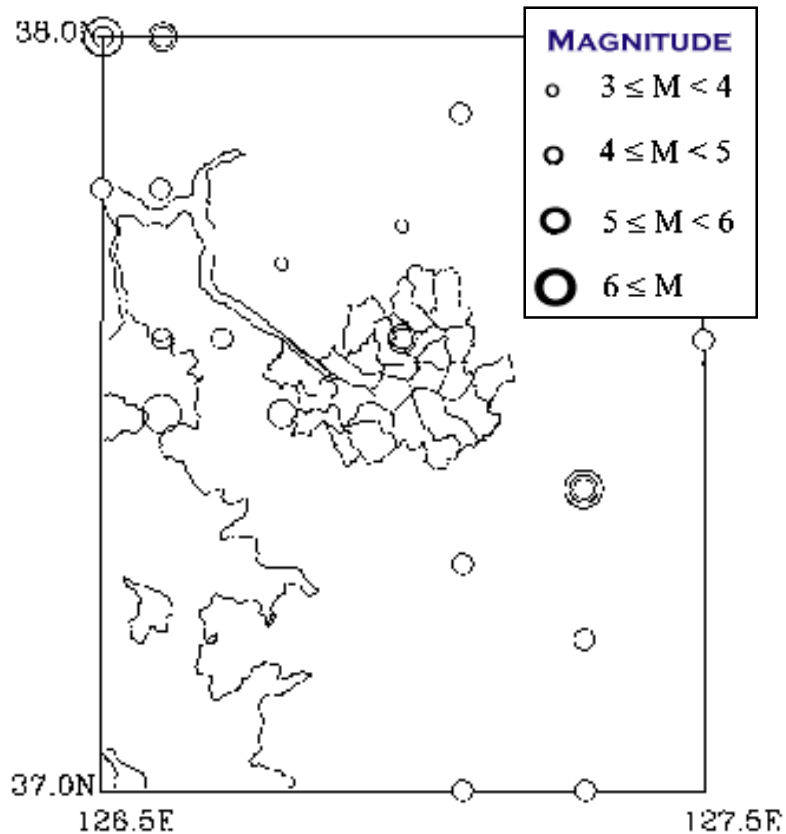

- **Intensity (역사지진)**

- 진도 5이상 59회
- 진도 6이상 23회
- 지진피해보고 8회

- **Magnitude(계기지진)**

- 규모 2.0 이상 24회
- 규모 4.0 이상 2회

# 5 지진의 크기를 표시하는 방법은 어떤 것이 있나요?

## 규모는



발생한 지진에너지의 크기를 나타내는 척도로서 지진계에 기록된 진폭을 진원깊이, 진앙거리 등을 고려하여 지수로 나타낸 것입니다.

## 진도는

어떤 장소에서 지반진동을 사람이 느끼는 감각, 주위의 물체, 구조물 그리고 자연계에 대한 영향을 계급별로 분류시킨 것입니다. 발생된 지진으로 인해 지역별로 흔들린 정도를 나타내는 것입니다.



### 지반진동이란?

- ▶ 땅이 흔들리는, 움직이는 현상을 말함.

규모와 진도는 다른 것입니다!  
예를 들면, 발생한 지진에 대하여 규모는 5.2로 일정 하더라도, 진도는 거리에 따라 다른 값을 갖습니다!

# Magnitude

릭터 규모(영어: Richter magnitude, 리히터 규모, 리히터지진계)는 지진의 강도를 나타내는 용어로서, ML 단위로 표기한다. 1935년, [미국](#)의 지질학자 찰스 리히터(Charles Richter)가 지진파를 측정해 지진의 에너지를 추정하는 방법을 개발했다.

릭터 규모는 지진계에서 관측되는 가장 큰 진폭으로부터 계산된 로그값을 바탕으로 만들어진 단위이다. 예를 들어, 리히터 규모 5.0의 지진이 갖는 진폭은 리히터 규모 4.0의 지진보다 진폭이 10배 크다.(위키피디아 참조)

지진 발생 시 방출되는 에너지는 그것의 파괴력과도 밀접한 관계가 있다. 흔히 TNT([핵폭탄](#)의 폭발 에너지의 단위)로 [화약](#)의 폭발 에너지를 환산한 수를 리히터 규모와 비교한다면 리히터 규모는 1.0부터 10.0까지 표시가 된다. 이에 따라 리히터규모 1.0- TNT 32kg/ 2.0-1t/3.0 - TNT 32t/4.0 - TNT 1kt (천톤)/5.0 - TNT 32kt(3만2천톤)/6.0 - TNT 1Mt (1억톤)/ 7.1 - TNT 50Mt(50억톤)/8.0 - TNT 1Gt /9.2 - TNT 31.6Gt /10.0 - TNT 1 teraton 등이다.

히로시마에 최초로 사용된 원자폭탄의 경우 약 15kt(1만5천톤) 정도의 폭발력을 지녔다고 하니 리히터규모로는 4.5 정도에 해당된다. 2004년 12월 동남아 해저에서 발생한 지진은 규모 9.0 로 히로시마 핵 250만개와 맞먹는다고 한다.

# Intensity

Intensity	Shaking	Description/Damage
I	Not felt	Not felt except by a very few under especially favorable conditions.
II	Weak	Felt only by a few persons at rest, especially on upper floors of buildings.
III	Weak	Felt quite noticeably by persons indoors, especially on upper floors of buildings. Many people do not recognize it as an earthquake. Standing motor cars may rock slightly. Vibrations similar to the passing of a truck. Duration estimated.
IV	Light	Felt indoors by many, outdoors by few during the day. At night, some awakened. Dishes, windows, doors disturbed; walls make cracking sound. Sensation like heavy truck striking building. Standing motor cars rocked noticeably.
V	Moderate	Felt by nearly everyone; many awakened. Some dishes, windows broken. Unstable objects overturned. Pendulum clocks may stop.
VI	Strong	Felt by all, many frightened. Some heavy furniture moved; a few instances of fallen plaster. Damage slight.
VII	Very strong	Damage negligible in buildings of good design and construction; slight to moderate in well-built ordinary structures; considerable damage in poorly built or badly designed structures; some chimneys broken.
VIII	Severe	Damage slight in specially designed structures; considerable damage in ordinary substantial buildings with partial collapse. Damage great in poorly built structures. Fall of chimneys, factory stacks, columns, monuments, walls. Heavy furniture overturned.
IX	Violent	Damage considerable in specially designed structures; well-designed frame structures thrown out of plumb. Damage great in substantial buildings, with partial collapse. Buildings shifted off foundations.
X	Extreme	Some well-built wooden structures destroyed; most masonry and frame structures destroyed with foundations. Rails bent.

- The Modified Mercalli (MM) Intensity Scale, developed in 1931 by the American seismologists
- Building construction quality assumed per the 1930's US west coast practice, modified in the 1950's



구분	진도	MMI 진도 기준			
		감각	위치변동 및 추락	구조물, 가구피해	지반피해
특수조건하 감지	I	극히 미세한 진동 : 특수조건 하에 극소수 감지			
	II	안정된 상태 또는 고층건물 상 층의 일부감지			
일반적인 감지	III	실내의 소수 감지, 경량의 트 럭이 지나가는 느낌			
	IV	실내의 다수 감지, 수면중 일 부 깨어남,			
	V	실내 모든 사람 감지, 실외 대 부분 감지	출입문의 개폐, 작은 물체 위치변동 및 추락		
불안감 피해	VI	다수 불안으로 밖으로 나감, 똑바로 걸을수 없음	가구의 위치 변동 및 부분 파손	약한 건물(D급)의 회벽떨어짐, 균열	
	VII	모든 사람 불안, 밖으로 나감, 서있기 곤란	VI급 이상의 피해	보통 건물(C급) 약간피해 부실건물(D급) 상당한 피해	작은 사태 콘크리트 관개도랑 피해
공포감 견고한 구조물 피해	VIII	공포감 운전 장애	"	견고한 벽돌건물(B급) 약간 피 해, 일반건물(C급) 부분적 붕괴	약간의 액상화 젖은 땅과 경사지에 균열
	IX	모든 사람 공포느낌	"	견고한 건물(B급) 심한 피해 또는 붕괴	지표면의 균열 발생, 지 하파이프관 파손
	X	"	"	대부분 견고한 건물 및 구조물 이 기초와 함께 파괴	지표면 균열, 대규모 사 태, 아스팔트, 콘크리트 포장도로 균열
구조물 완전파괴	XI	"	"	철로 심하게 휘어진 구조물 거의 완전파괴	지하파이프 완전 작동 불 능
	XII	지면의 파도형태, 움직임 느낌	물체가 공중으로 던져짐		