

Image courtesy of FMC Technologies

# Offshore Equipment

Yutaek Seo

# Lecture Plan

<b>1</b>	<b>Offshore projects with various equipment</b>
<b>2</b>	<b>Offshore pipeline design</b>
<b>3</b>	<b>Production facility</b>
<b>4</b>	<b>Process selection</b>
<b>5</b>	<b>Mechanical design of pressure vessels</b>
<b>6</b>	<b>Two phase oil and gas separation</b>
<b>7</b>	<b>Valve, Fitting, and Piping details</b>
<b>8</b>	<b>Compressors</b>
<b>9</b>	<b>Reciprocating compressors</b>
<b>10</b>	<b>Topside process design – gas processing system</b>
<b>Text book</b>	<ul style="list-style-type: none"><li>- Printed materials: Topic 1, 2, 10</li><li>- Surface production operations, Vol. 2 (Gas-Handling): Topic 7, 8, 9</li><li>- Surface production operations, Vol. 1 (Oil-Handling): 3, 4, 5, 6</li></ul>
<b>Rating</b>	<ul style="list-style-type: none"><li>- Homework, Quiz 20% (March, May)</li><li>- Midterm 30% (April)</li><li>- Final 40% (June)</li><li>- Attendance 10%</li></ul>

# Typical Field Layout

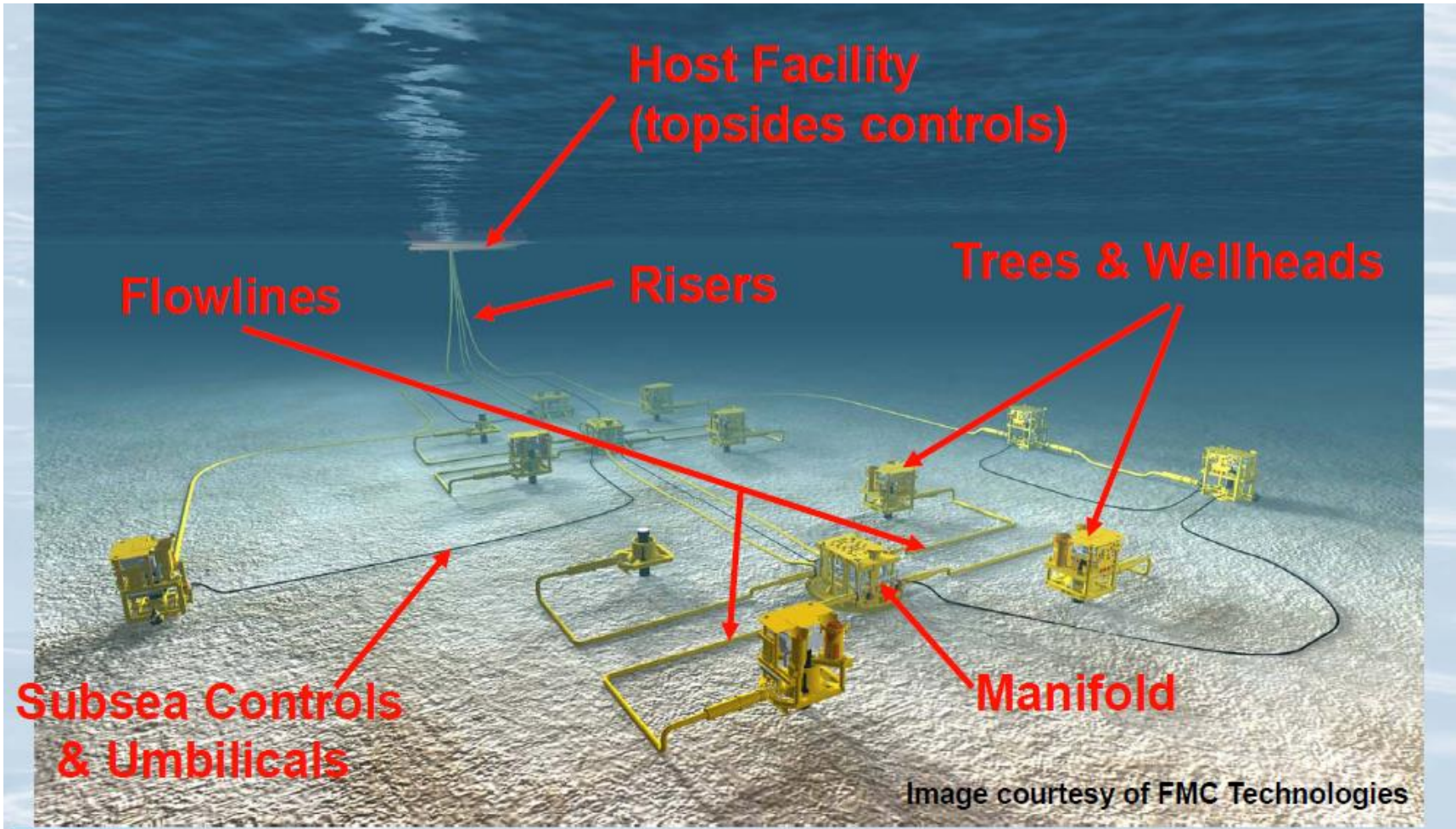



# Oil FPSO

- Processes hydrocarbons from subsea template into oil, LPG, sales gas, etc.
- A converted tanker or purpose built vessel – may be ship shaped
- Eliminate the need for costly long-distance pipelines, which is effective in remote or deep water developments

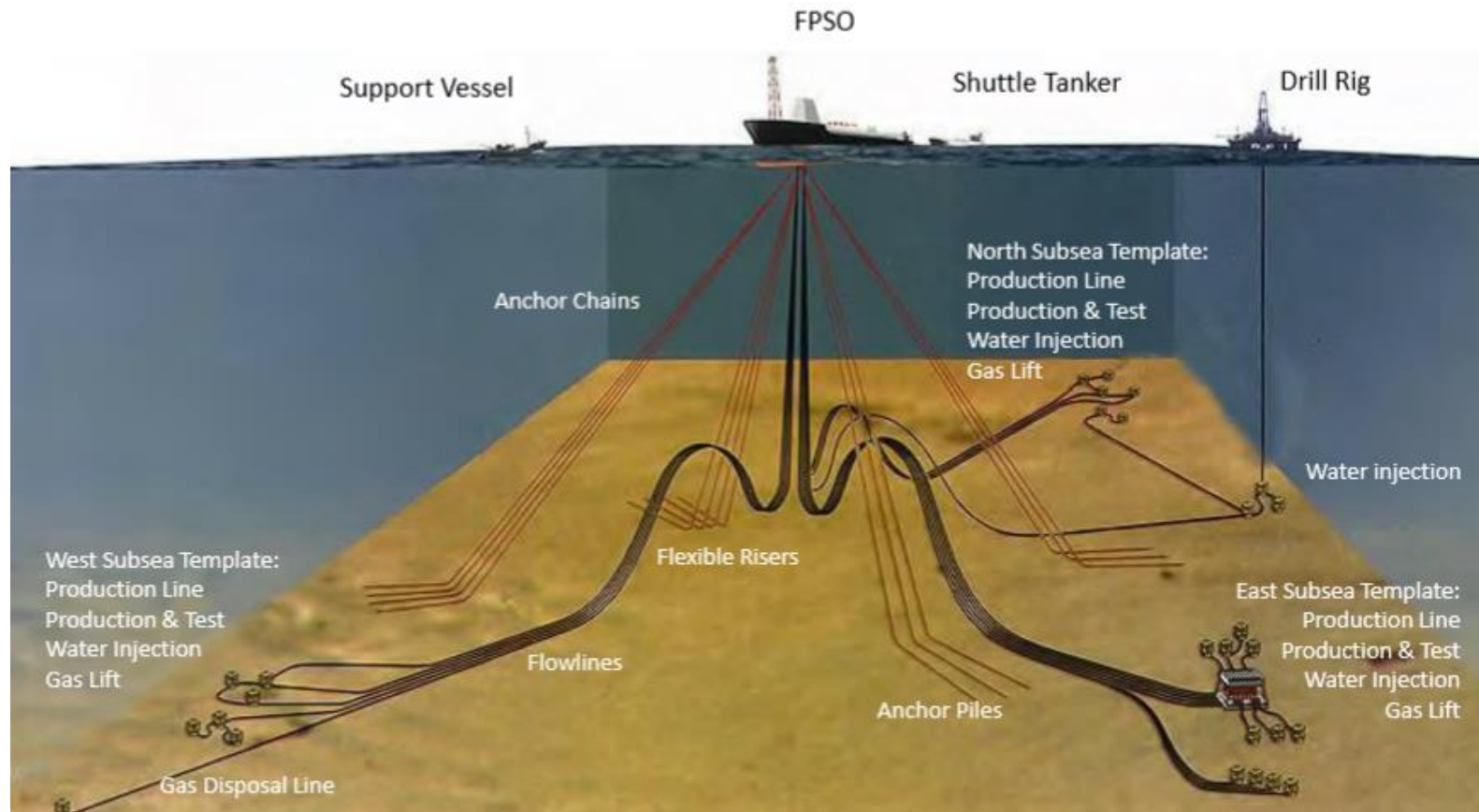

# FPSO in Western Australia

- Vincent oil field**

- : Located offshore Exmouth in Western Australia
- : Water depth 350m, 17° API crude from 8 wells
- : Oil column thickness 8.5 ~ 19.0 m
- : Total Liquid processing capacity 120,000 b/d with total storage capacity of 1.2 million barrels of oil
- : Water (150,000 b/d) & Gas (80 MMscf/d) Injection
- : Dual sided hull and disconnectable mooring

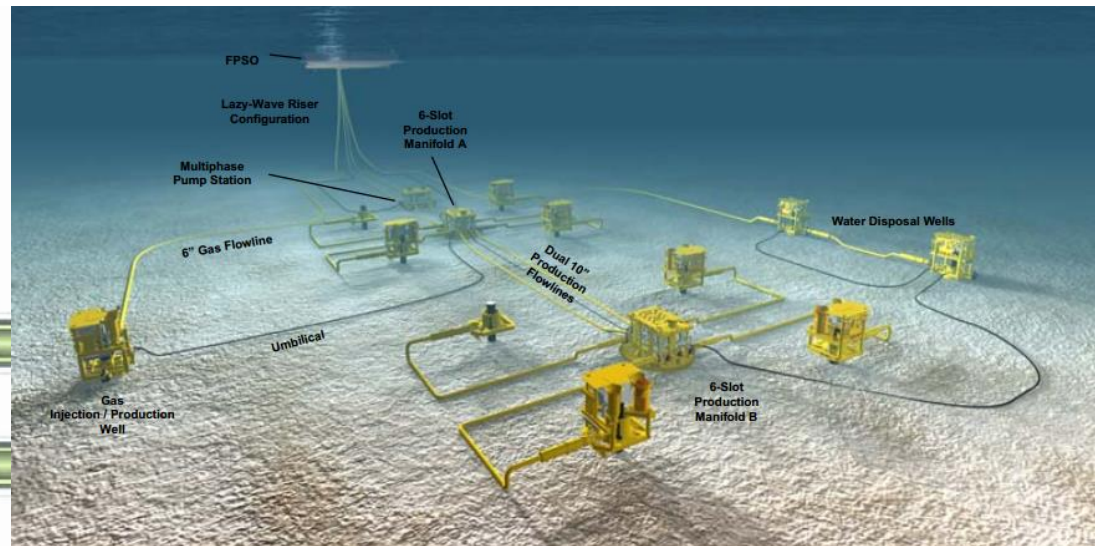
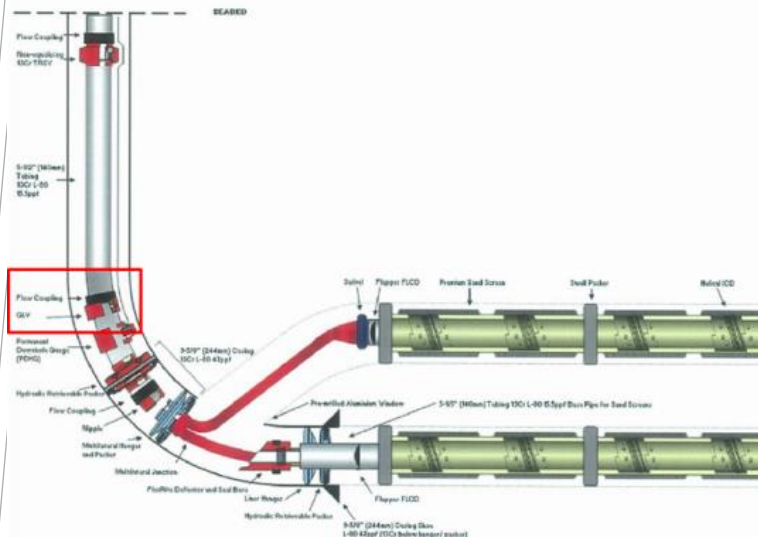

# INPEX - Ichthys Field

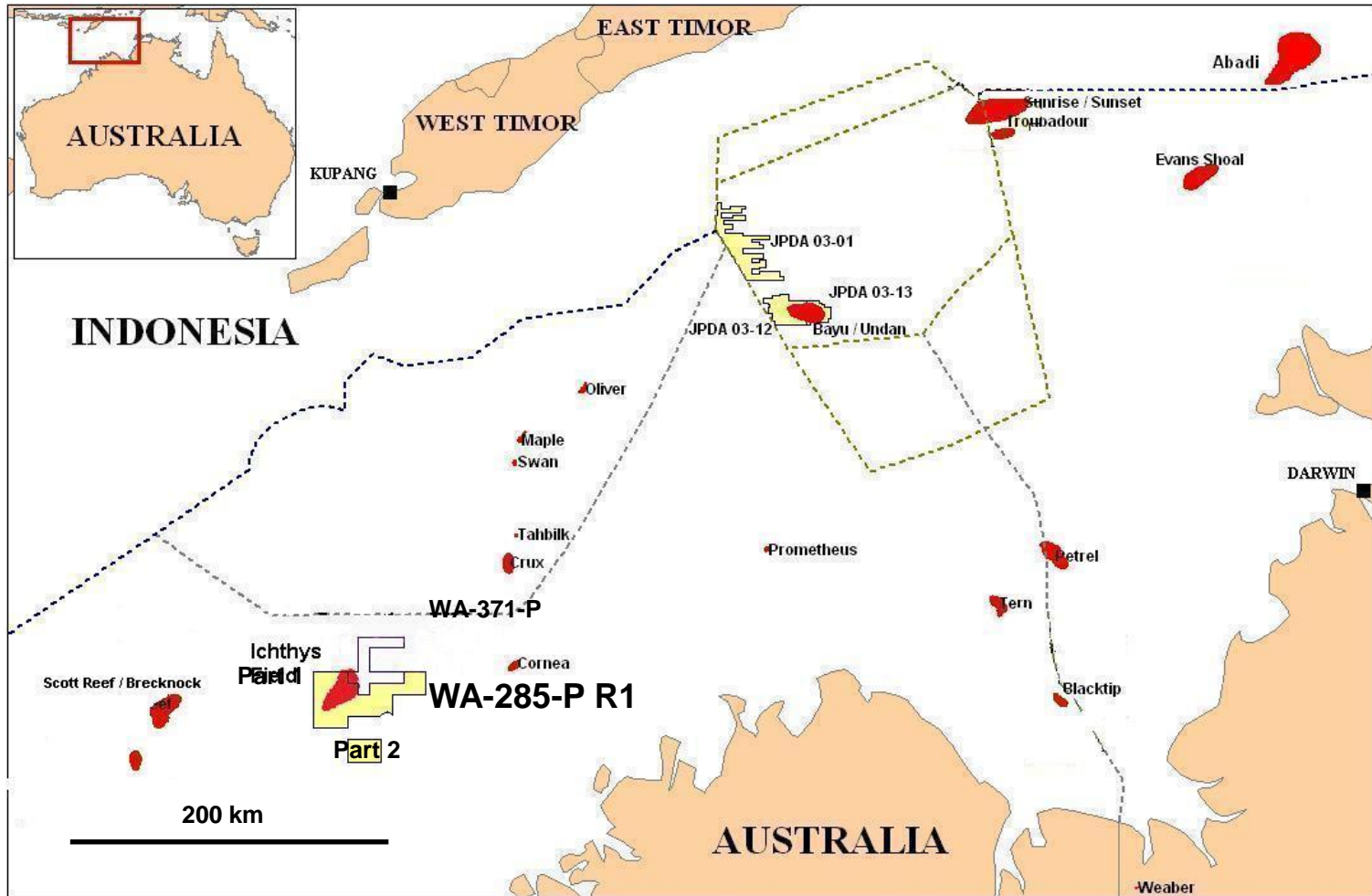

- Approximately 200 km from the mainland
- 250–270 m water depth



# Field Development Plan

## FPSO

- Condensate treatment and export
- MEG regeneration

## Semi-submersible

- Fluid Separation
- Gas dehydration
- Gas export

## Infield facilities

- 50 wells with 13 drill centres
- 10 \* 18" corrosion resistant flowlines
- 13 subsea manifolds
- 10 \* 12" Flexible risers

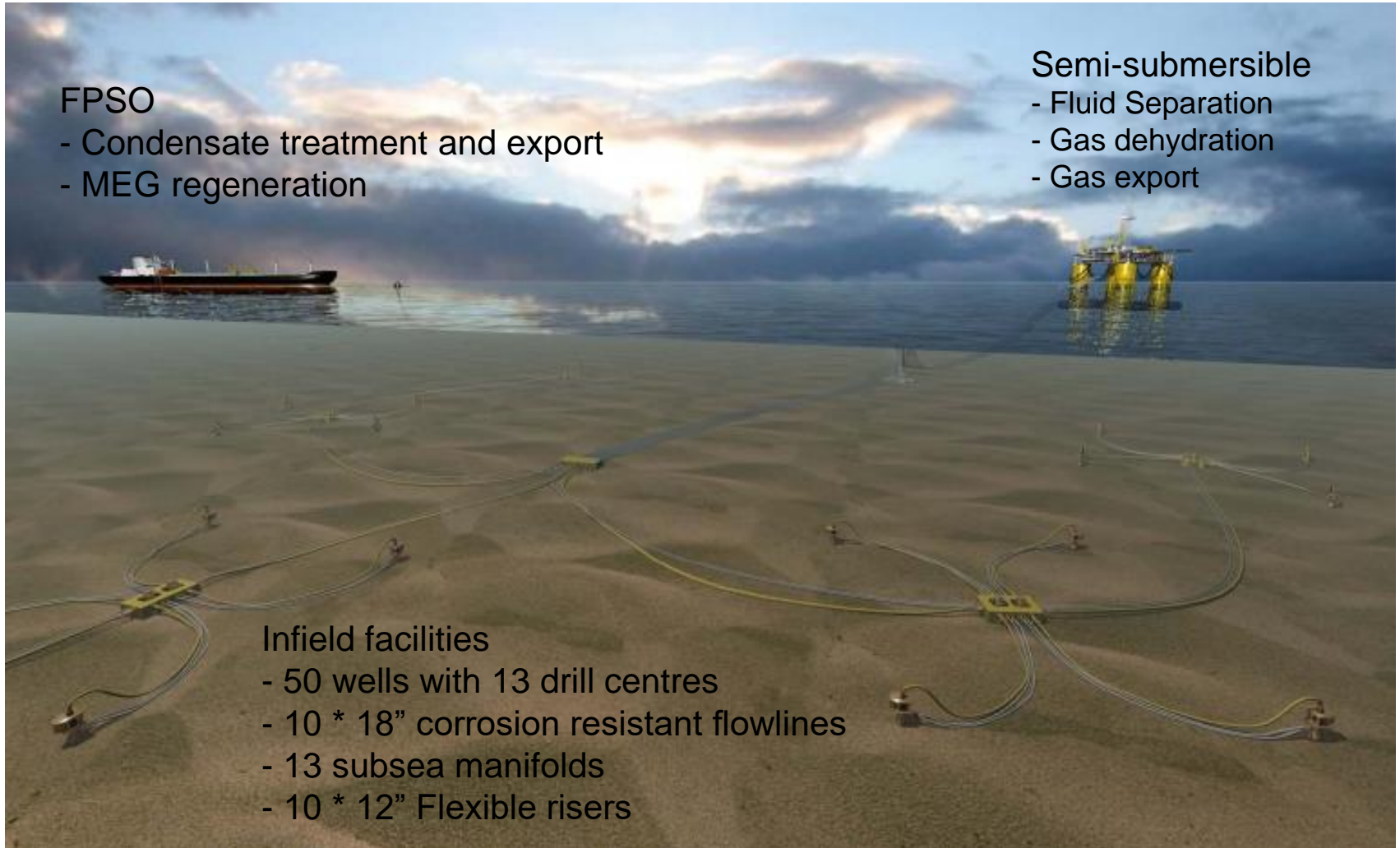





# Subsea Tree

- Primary production and safety device for a well
- Essentially consists of a number of valves to regulate flow and isolate the tree from the well, and monitor the production fluids

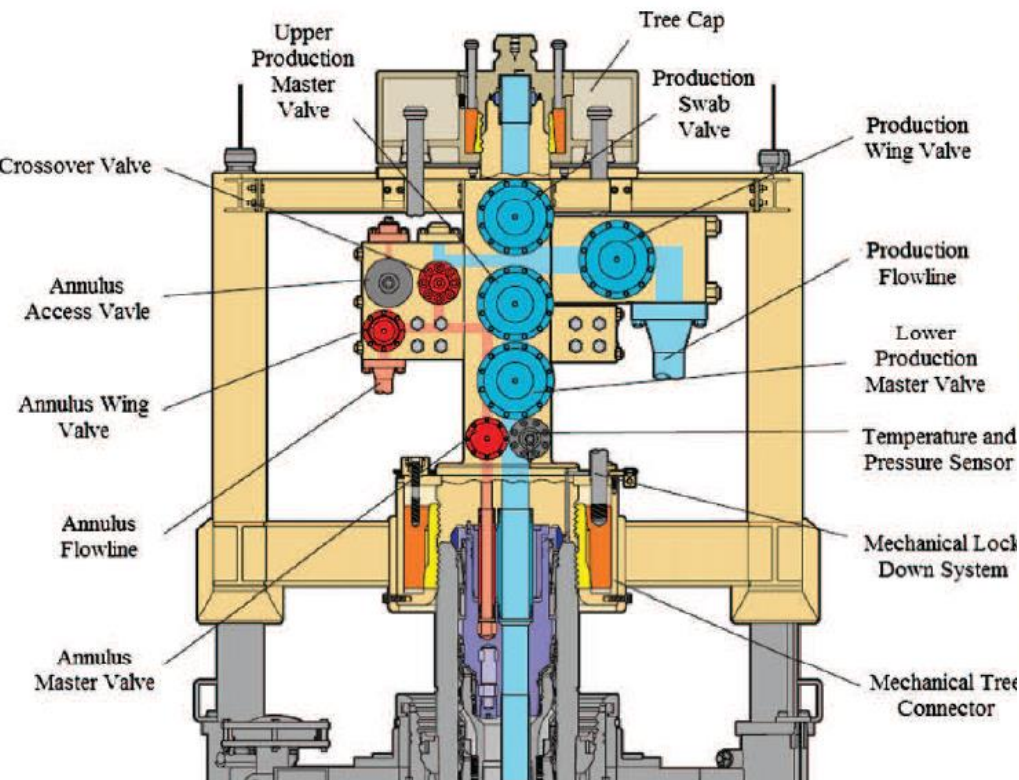

# Manifold/Template

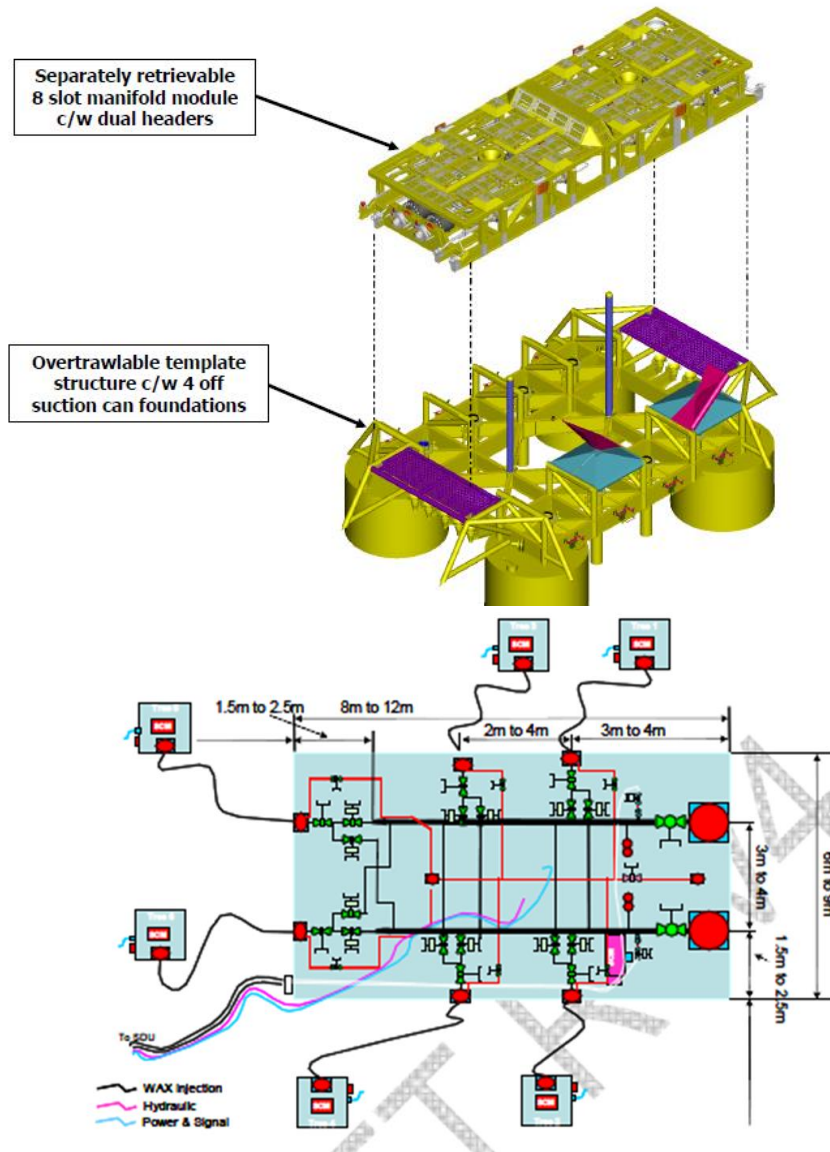

- A template is a seabed founded structure that provides a guide for other equipment
- A manifold is a system of piping and associated equipment used to gather produced fluids. Associated equipments may include
  - : Isolation valves
  - : Flowline connectors
  - : Xmas tree connectors
  - : Flow control chokes
  - : Umbilical termination and distribution

# PLEM/PLET

- PLEM (Pipeline End Manifold)
  - : Used to comingle 2 or more pipelines together and eliminate the need for additional risers

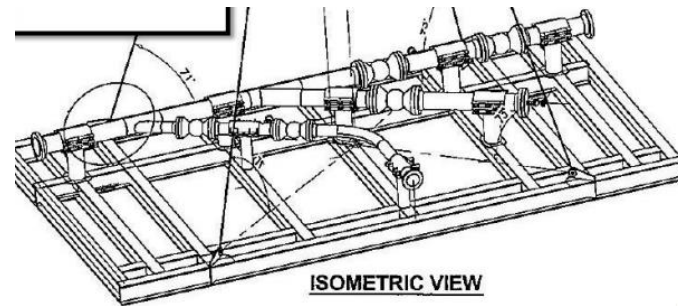

- PLET (Pipeline End Termination)
  - : Used to link manifold to the production pipeline

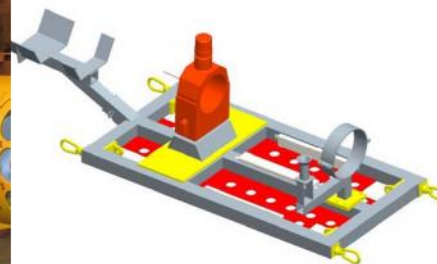



# Flowline

- Transport reservoir fluid to processing facilities
- Pipelines
  - : horizontal transfer from wellhead
  - : these may be very long
  - : may be rigid or flexible pipe
  - : commonly called flowlines

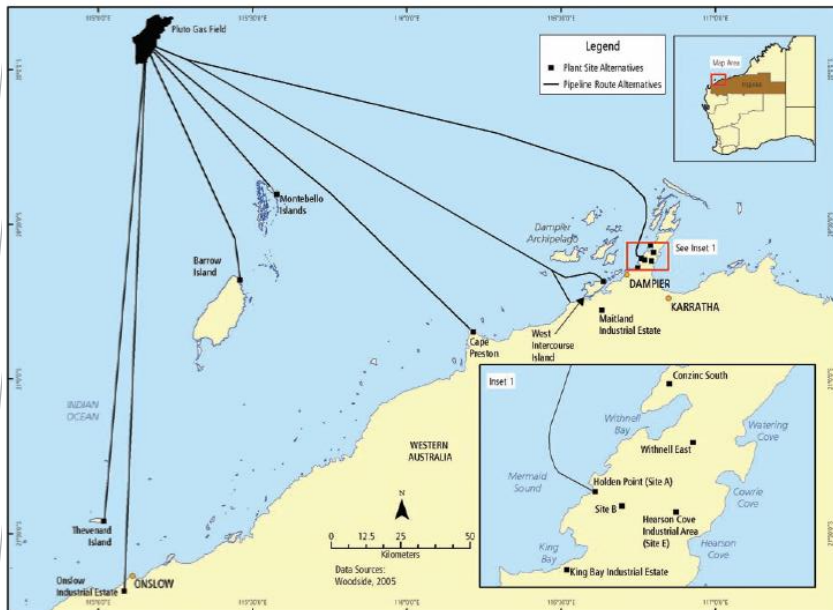

# Riser

- Vertical transfer to above surface processing facilities
- Either Rigid or Flexible
- Rigid risers normally for fixed platforms
  - : pre-installed inside jacket frame
  - : cost effective and added riser protection
- Flexible risers mainly for floating production system
  - : Flexibility and reliability
  - : Easy and rapid installation

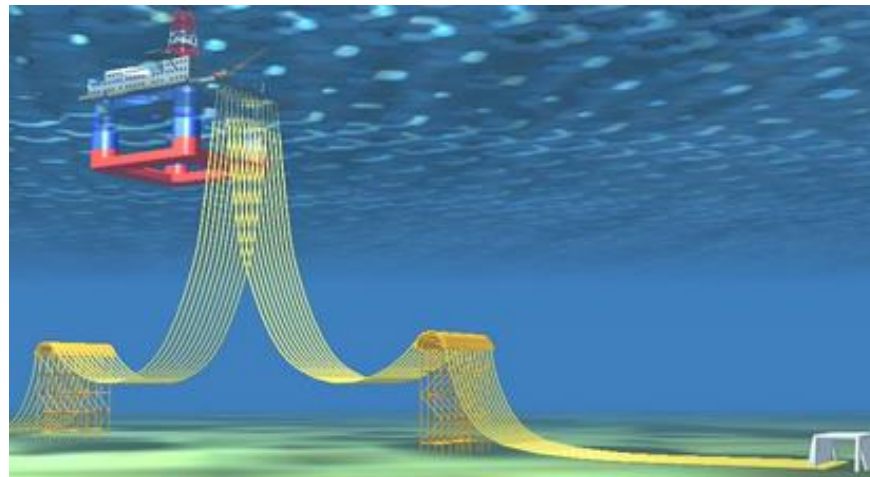
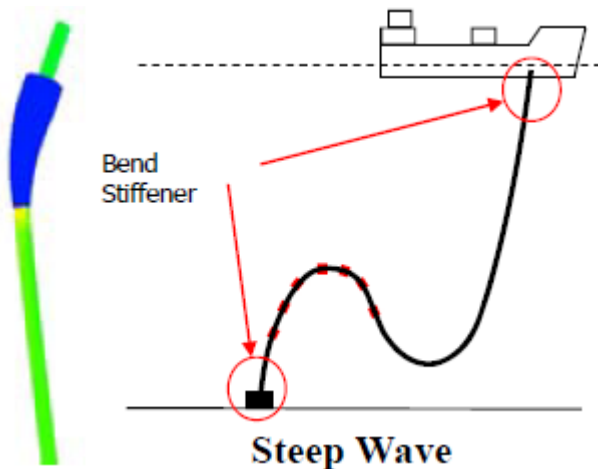

# Offshore Process Flow Diagram

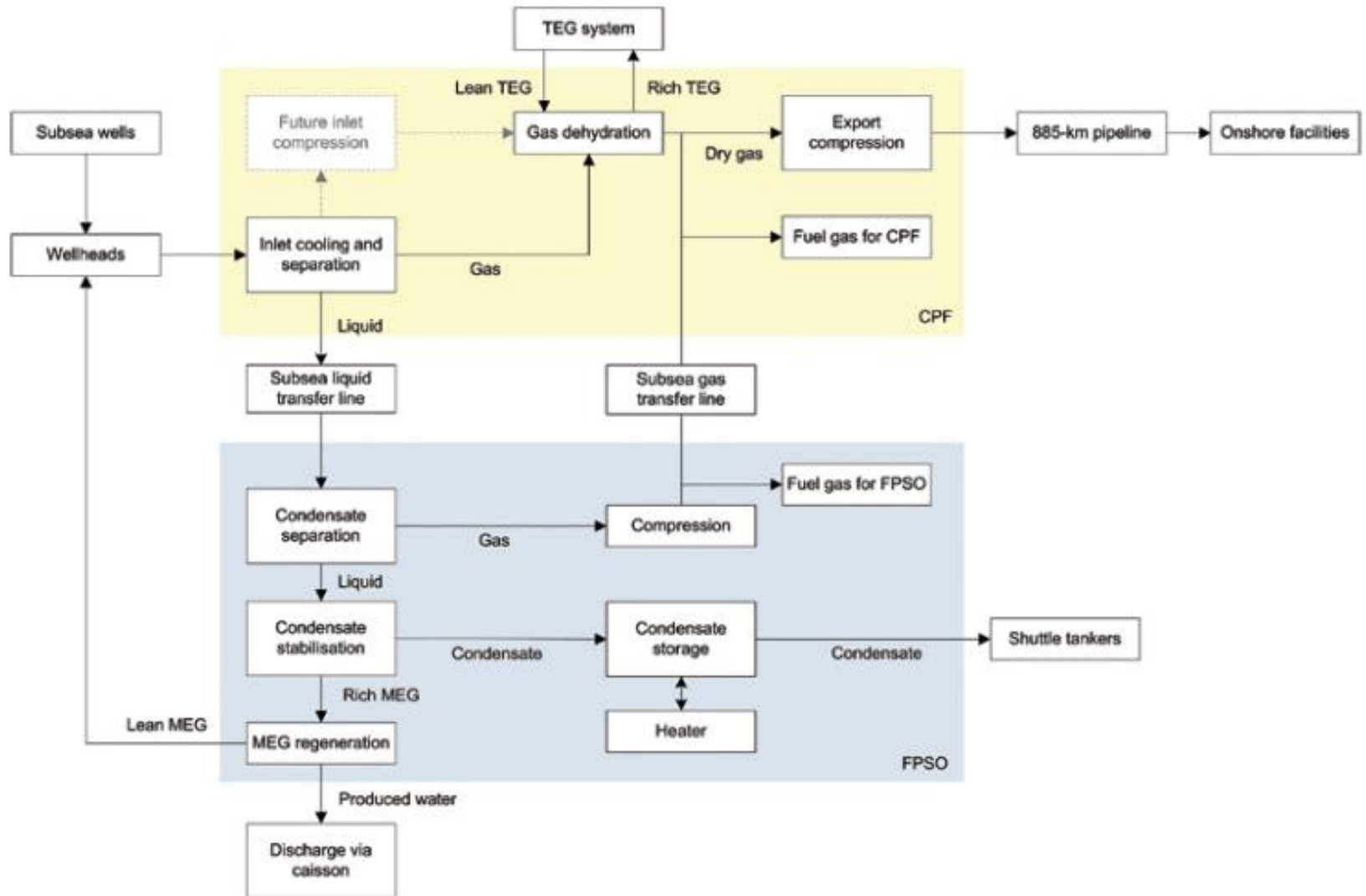



# CPF (Central Processing Facility)



- Design capacity of 1657 MMscf/d export gas
- 4 leg semi-submersible hull structure
- 4 group \* 7 mooring legs (28 total mooring legs)
- Inlet flow control and manifolding
  - : Each riser will have a topside choke
  - : Flowlines are connected by manifolds to three production trains
- Inlet separation system
  - : Inlet surge vessel to separate bulk liquids
- TEG gas dehydration
- Gas export compression
  - : Four trains of export compression (each sized for 33% of total throughput)
  - : Discharge at ~20 500 kPa to maintain export flow
- Inlet booster compression – Future option
- Condensate export to the FPSO
- Accommodation – 150 beds
- Utilities
  - : Chemical injection package, TEG regeneration, etc (Antifoam, Wax inhibitor, Methanol, Scale inhibitor, MEG, TEG, Subsea hydraulic fluid)

# FPSO (Floating Production Storage and Offtake)



- Weather veining turret mooring
  - : 3 group \* 7 mooring legs (21 total)
- 12 path swivel
- Product storage of 1.2 million barrels
- Condensate treatment and stabilization
  - : Series of 3-phase separators, coalescers, and heat exchanger to stabilize the condensate up to 85 000 bpd
  - : Main tank capacity – 150 000 m<sup>3</sup>
- Mercury removal from condensate and water
- Flash gas compression
- MEG regeneration unit
  - : 2 \* 50% MEG regeneration plants
  - : Max. lean MEG injection of 100 m<sup>3</sup>/hr
  - : MEG storage tank capacity – 13 500 m<sup>3</sup>
- Produced water treatment facilities
- Condensate export system to shuttle tankers

# Inlet separation

- Following figure shows a schematic of gas-liquid separators and indicates the four types of separation:
- Primary separation
- Gravity settling
- Coalescing
- Liquid collecting

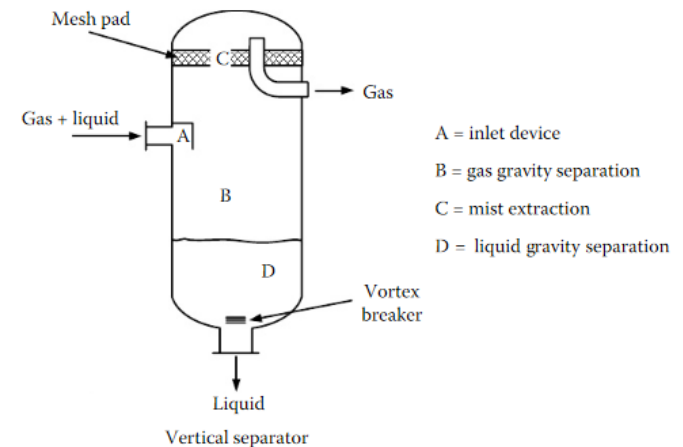
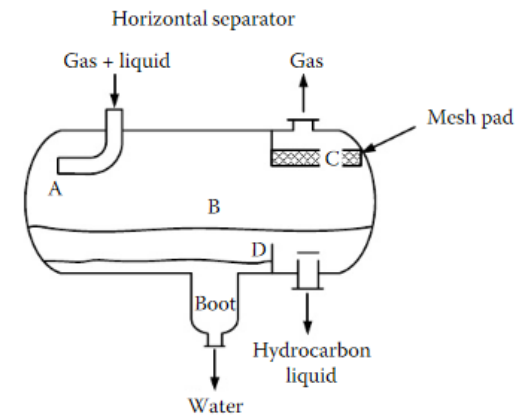
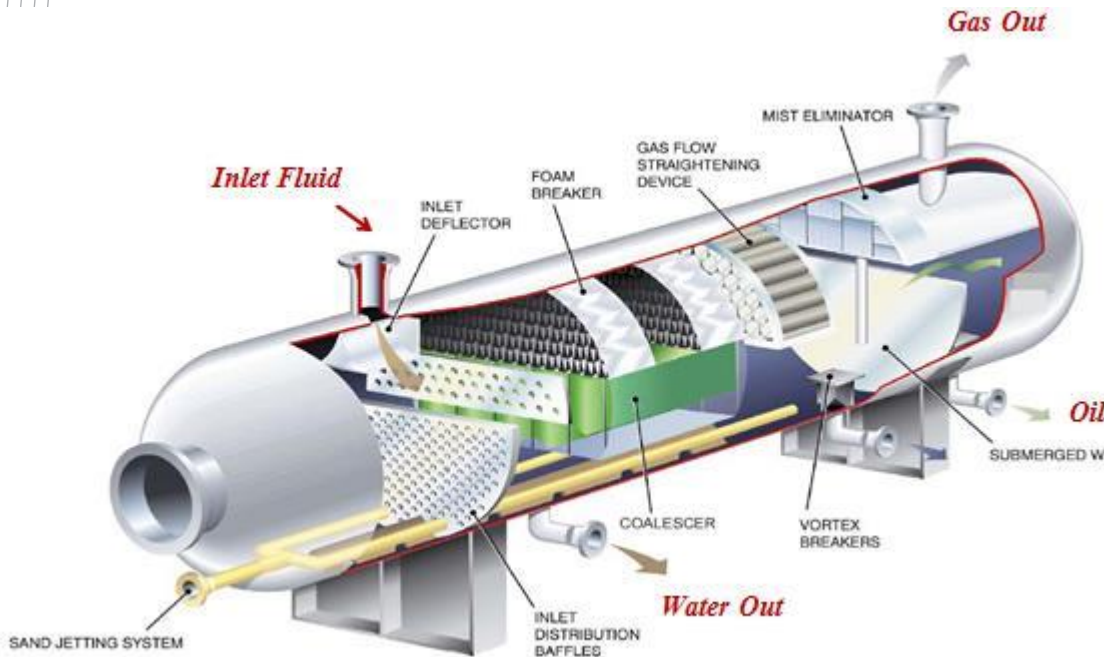



# Acid gas removal with MEA

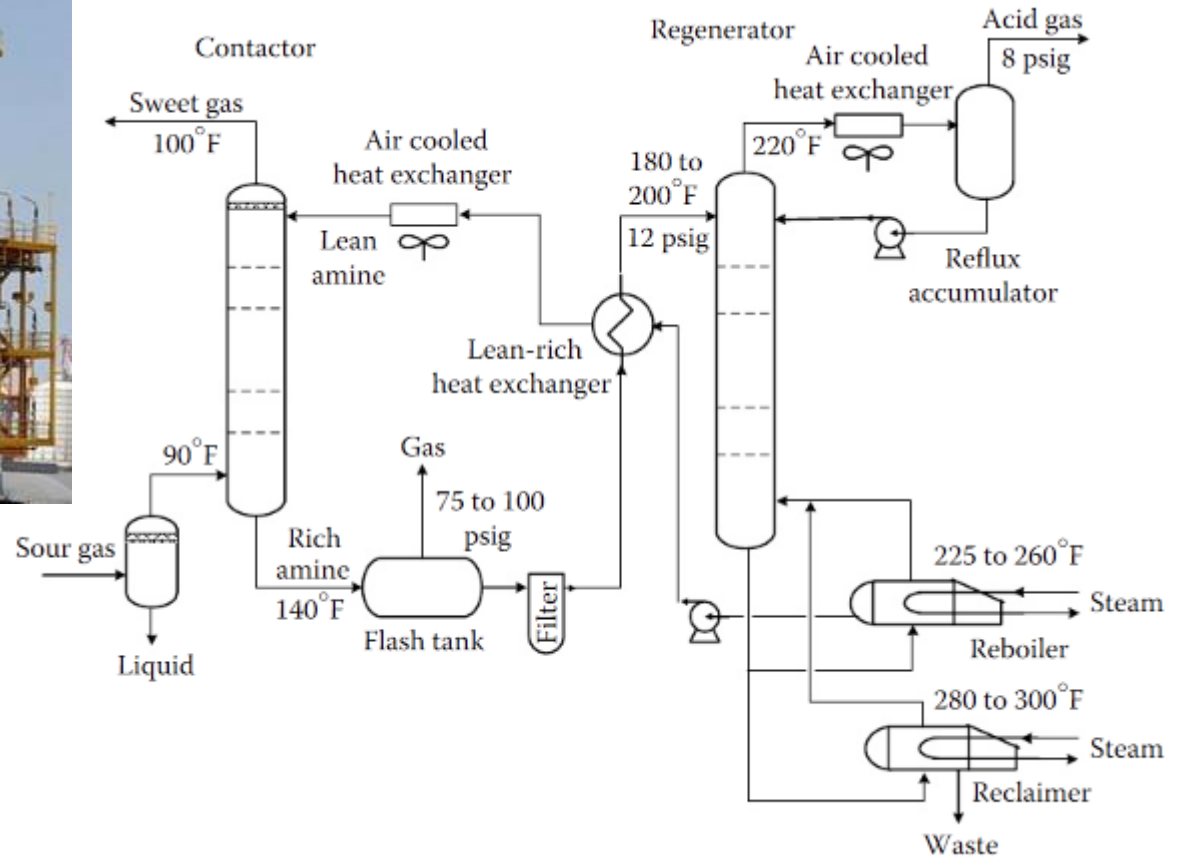

PFD of MEA treating process.

: Contactor operates at pressure up to 70 bar. Flow rates to reclaimer are 1 ~ 3 % of amine circulate rate

# Gas dehydration using TEG

- A typical, simplified flow sheet for a glycol absorption unit

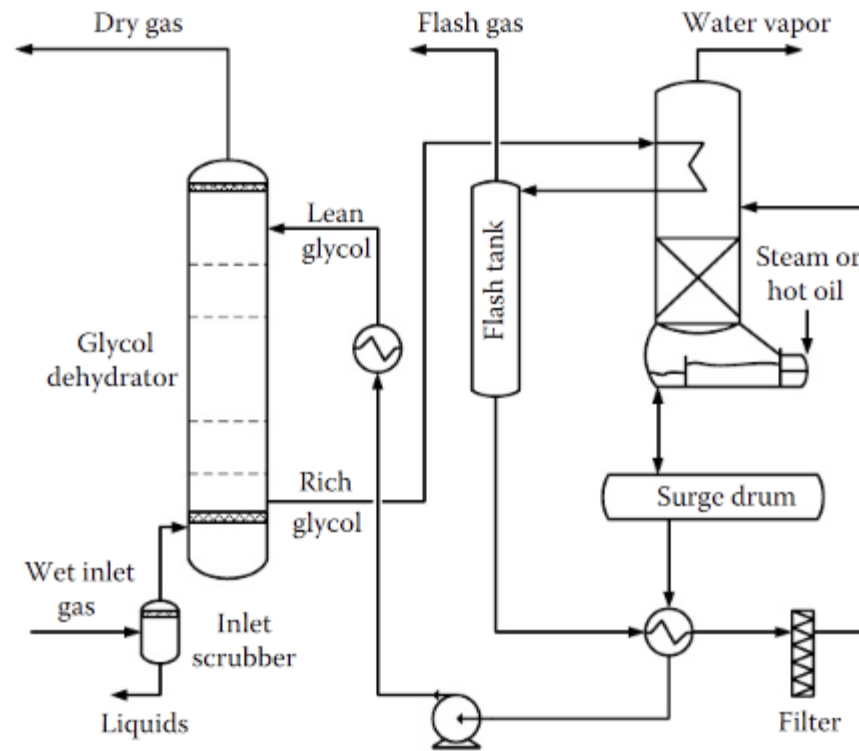

# NGL recovery

- Extensive fractionation of NGL

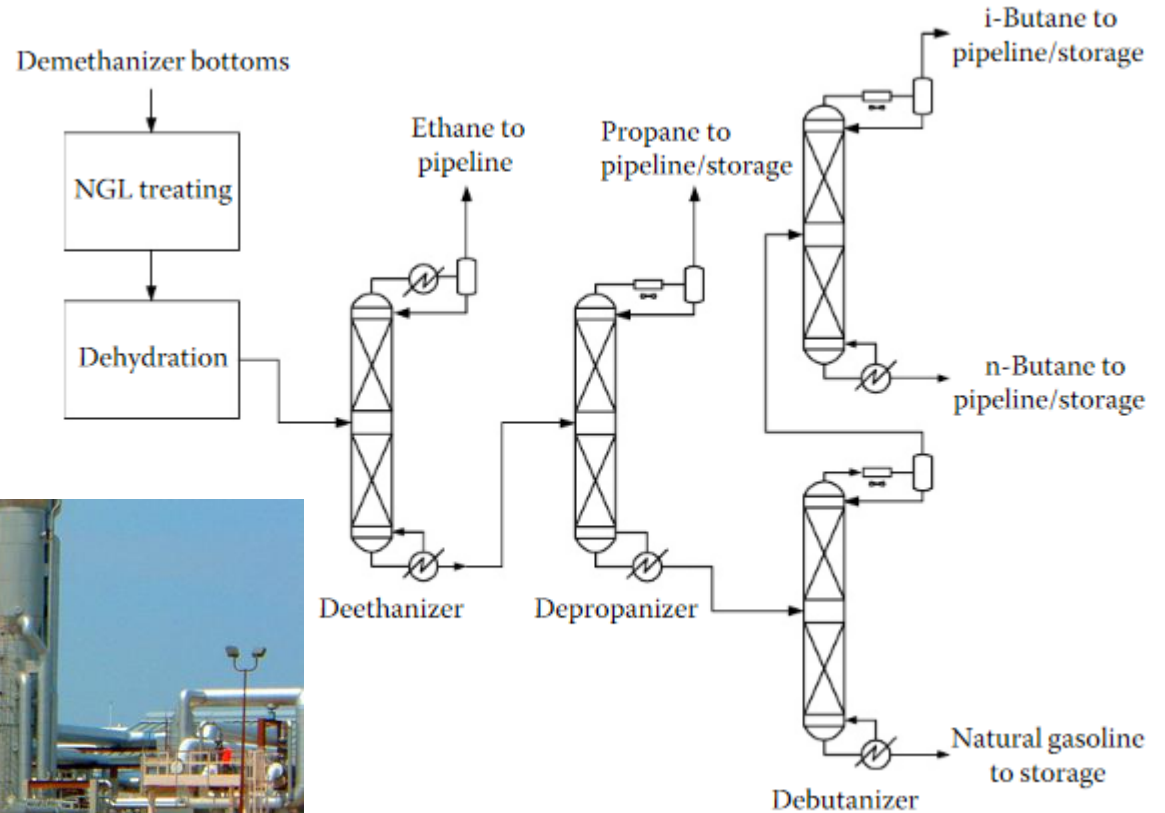



# Offshore facilities on topside

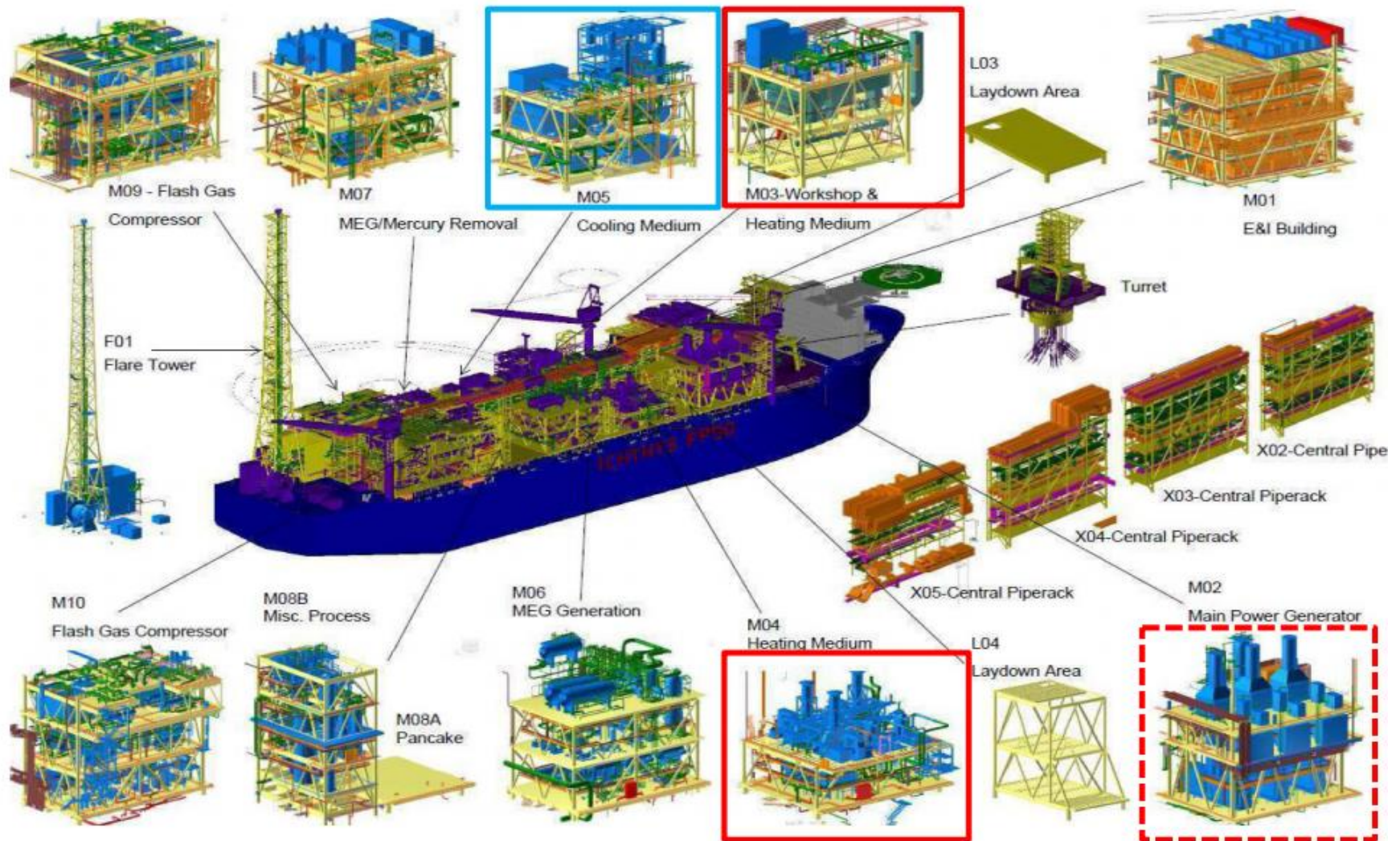



Thank you!