

**2017 Fall**

**“Calculation and Applications Phase Equilibria”**

# **Principles *of* Solidification**

**06.14.2017**

**Eun Soo Park**

**Office: 33-313**

**Telephone: 880-7221**

**Email: [espark@snu.ac.kr](mailto:espark@snu.ac.kr)**

**Office hours: by appointment**

# 7. Macroscopic Heat Flow and Fluid Flow

## 7.2. Fluid Flow

\* The ability of a molten metal to flow =

**(1) poured from a container in which it was melted into a mold in which it is to solidify.**

: effect of the macroscopic geometry of the casting (Chapter 7)

**(2) Relative motion of different parts of the liquid can occur while it is solidifying.**

: its implications in relation to the structure of the solidified metal (Chapter 8)

### 1) Viscosity of liquid metal

liquid metal : “Flow rate depends on the force” = “shear rate is proportional to the shear stress”

→ To compare “rates of flow”,

$$\text{Reynolds' number} = \gamma v l / \mu$$

$\gamma$  = density ,  $v$  = velocity,  
 $\mu$  = viscosity,  $l$  = linear dimension

\* **If the value of Reynolds' number is high (>1400 ) for a tube leading out of a containing vessel, the flow becomes turbulent and Q drops below the value that would be calculated from the above formula. → Derive the “Kinematic viscosity,  $\mu / \gamma$ ” from the above equation : Used for calculation of flow rate when pressure difference is caused by flowing liquid → **For solidification it is considered more important.****

## 7. Macroscopic Heat Flow and Fluid Flow

### \* Macroscopic fluid flow (poured into a mold)

### Mold Filling

Bernouli's Equation (incompressible flow):

$$p/w + Z + q^2/2g = \text{constant}$$

( $p$  = pressure  $w$  = specific weight  $q$  = velocity  
 $g$  = gravity  $z$  = elevation)

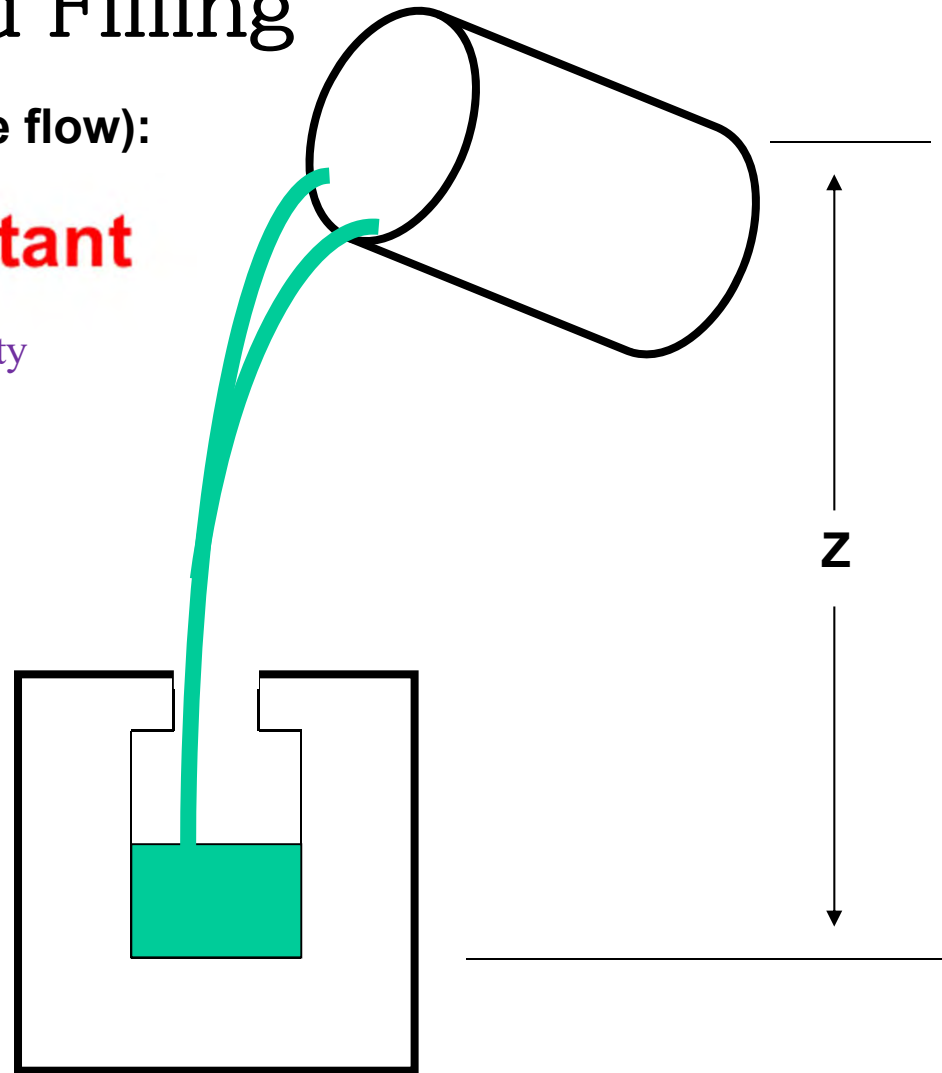
principle of conservation of energy

Reynold's Number:

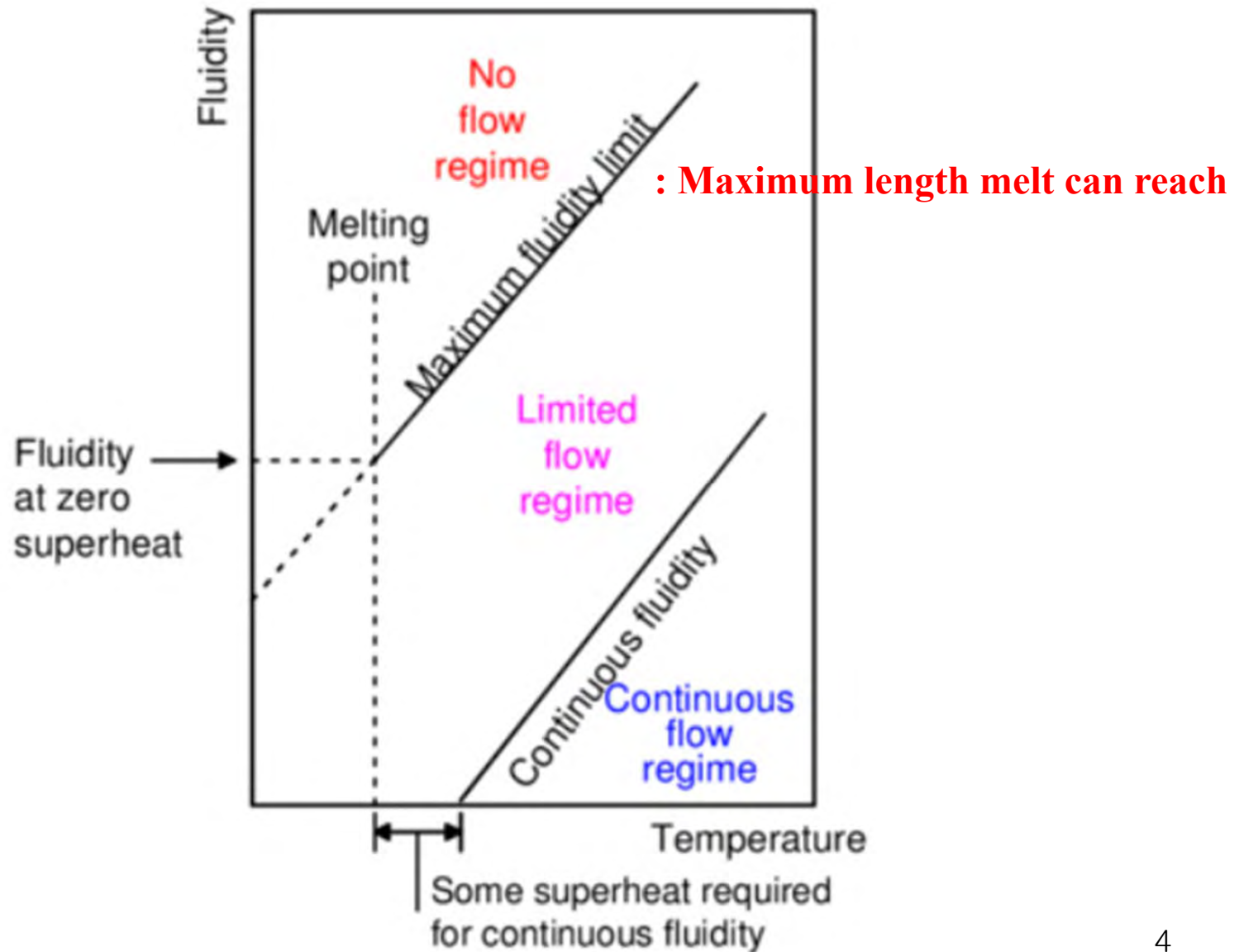
$$Re = \gamma v l / \mu$$

$\gamma$  = density ,  $v$  = velocity,  
 $\mu$  = viscosity,  $l$  = linear dimension

- Short filling times
- Potential Turbulence

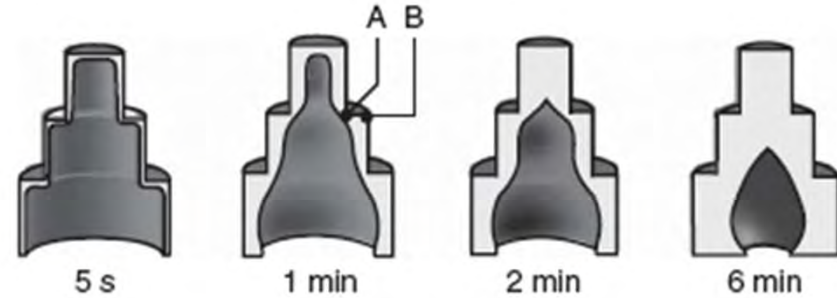


# Regimes of continuous, partial and impossible flow



## \* Macroscopic heat flow

### 1. Solidification Time in mold



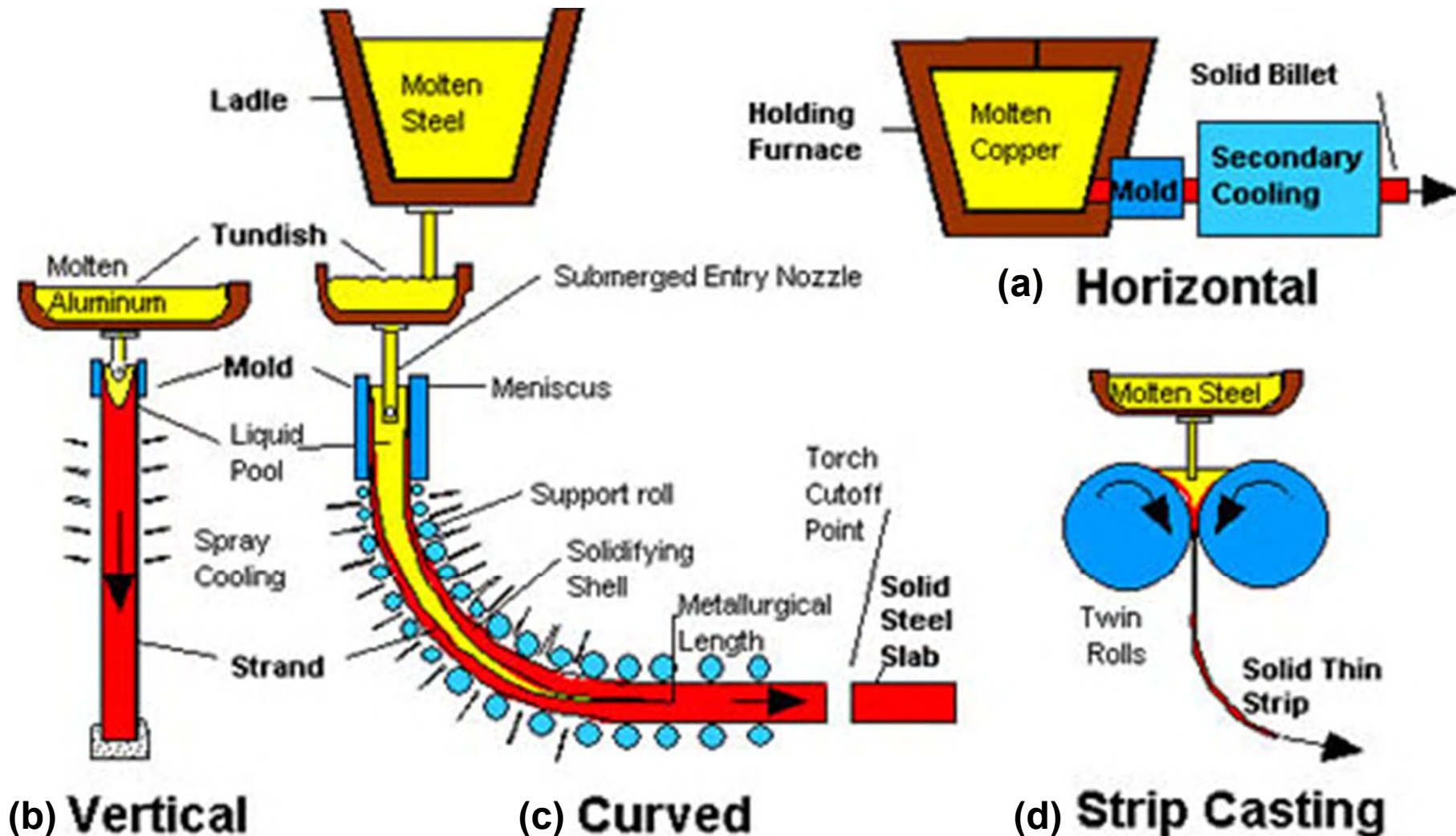
- Total solidification time  $T_{TS}$  = time required for casting to solidify after pouring
- $T_{TS}$  depends on size and shape of casting by relationship known as *Chvorinov's Rule*

$$T_{TS} = C_m \left( \frac{V}{A} \right)^n$$

where  $T_{TS}$  = total solidification time;  $V$  = volume of the casting;  $A$  = surface area of casting;  $n$  = exponent with typical value = 2; and  $C_m$  is *mold constant*.

## 2. continuous casting: a number of dynamic industrial process

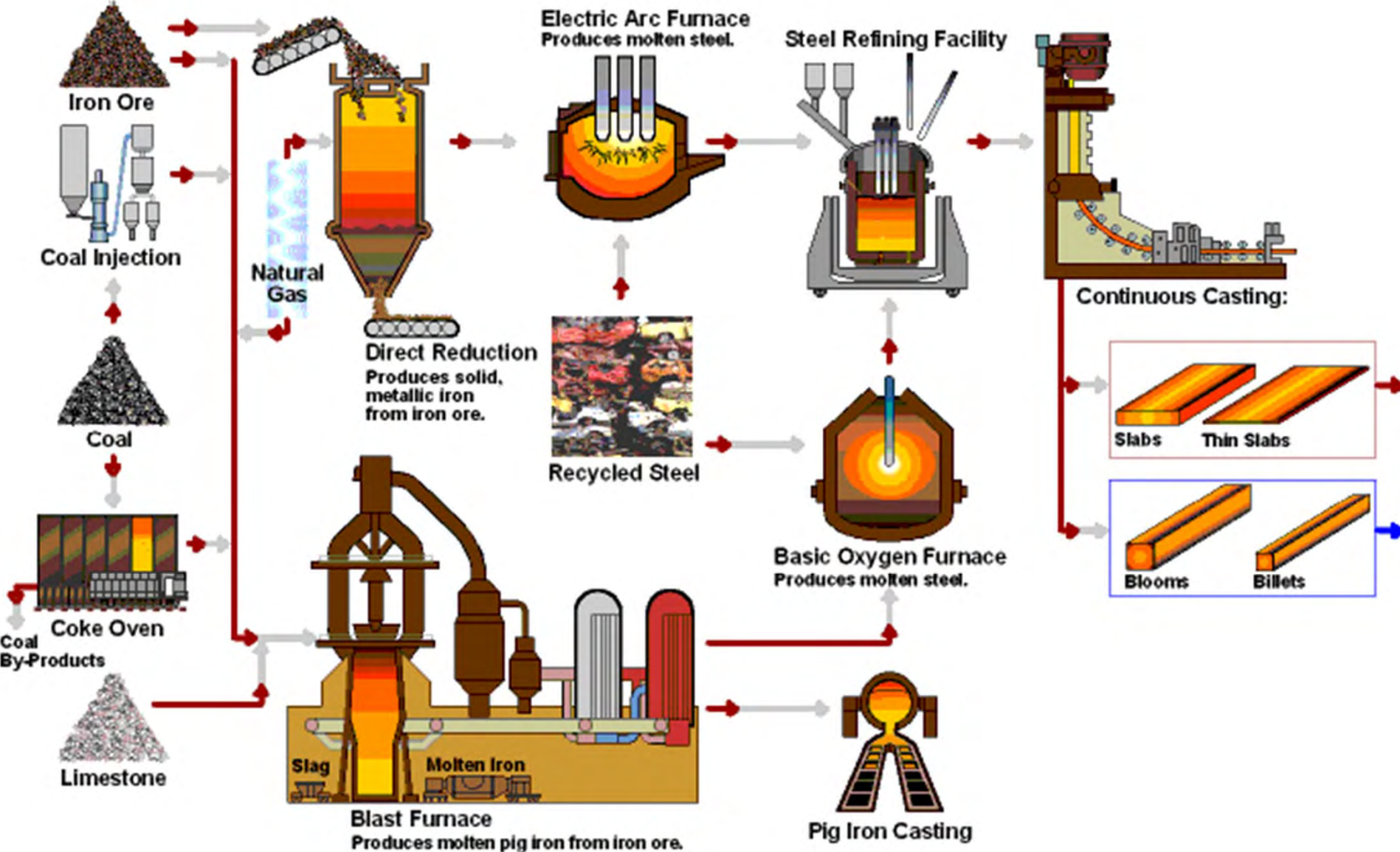
The molten metal is poured continuously into a water-cooled mold from which the solidified metal is continuously withdrawn in plate or rod form. (solid-liquid interface)



**continuous casting**

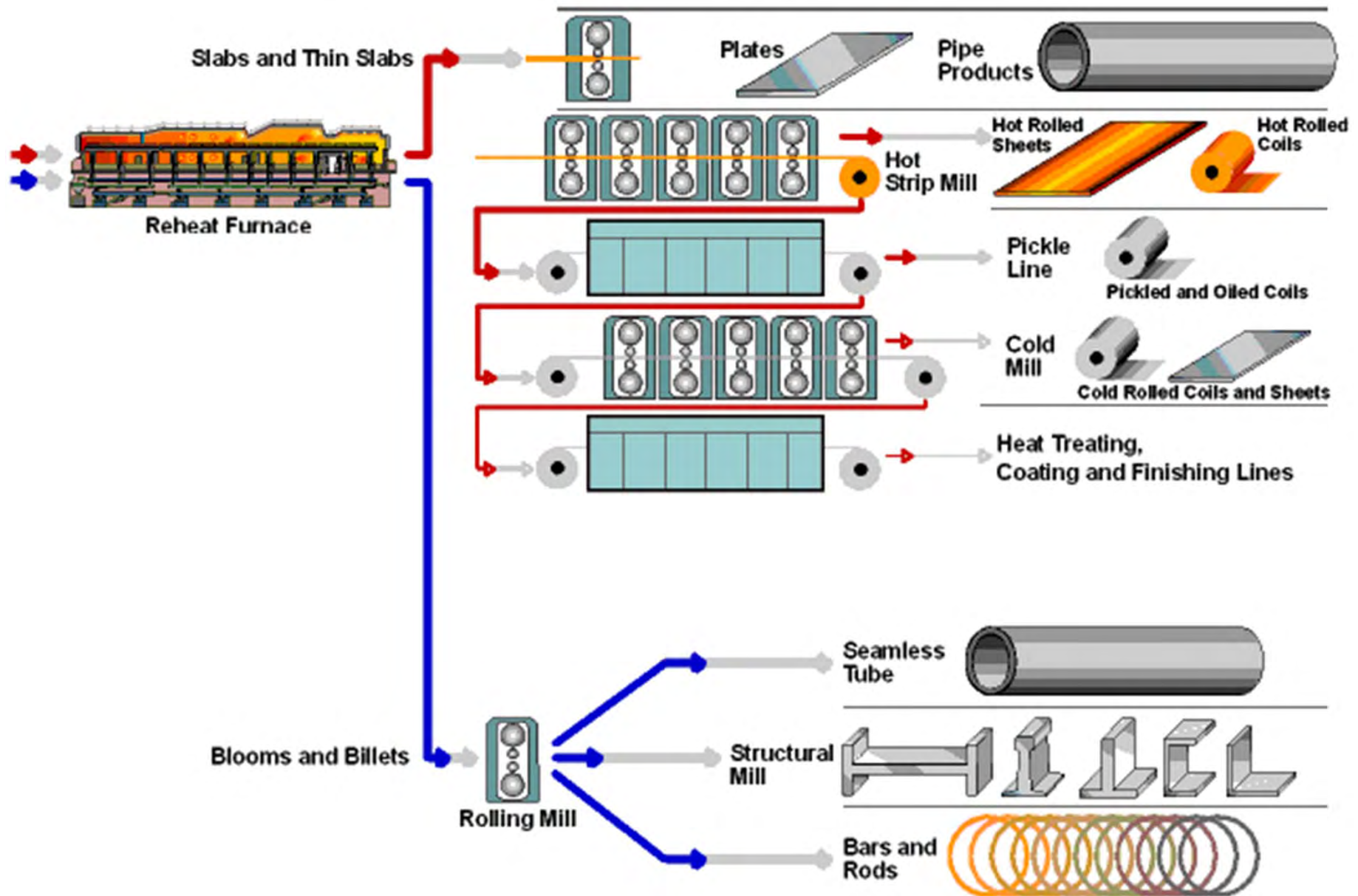


# continuous casting





## 4.4.3 continuous casting



# continuous casting: a number of dynamic industrial process

: large mass (economic advantage)/ high speed (property good)

→ **Process speed: related to latent heat removal & metal flow during solidification.**

① **Dynamic process: importance of isotherm distribution**

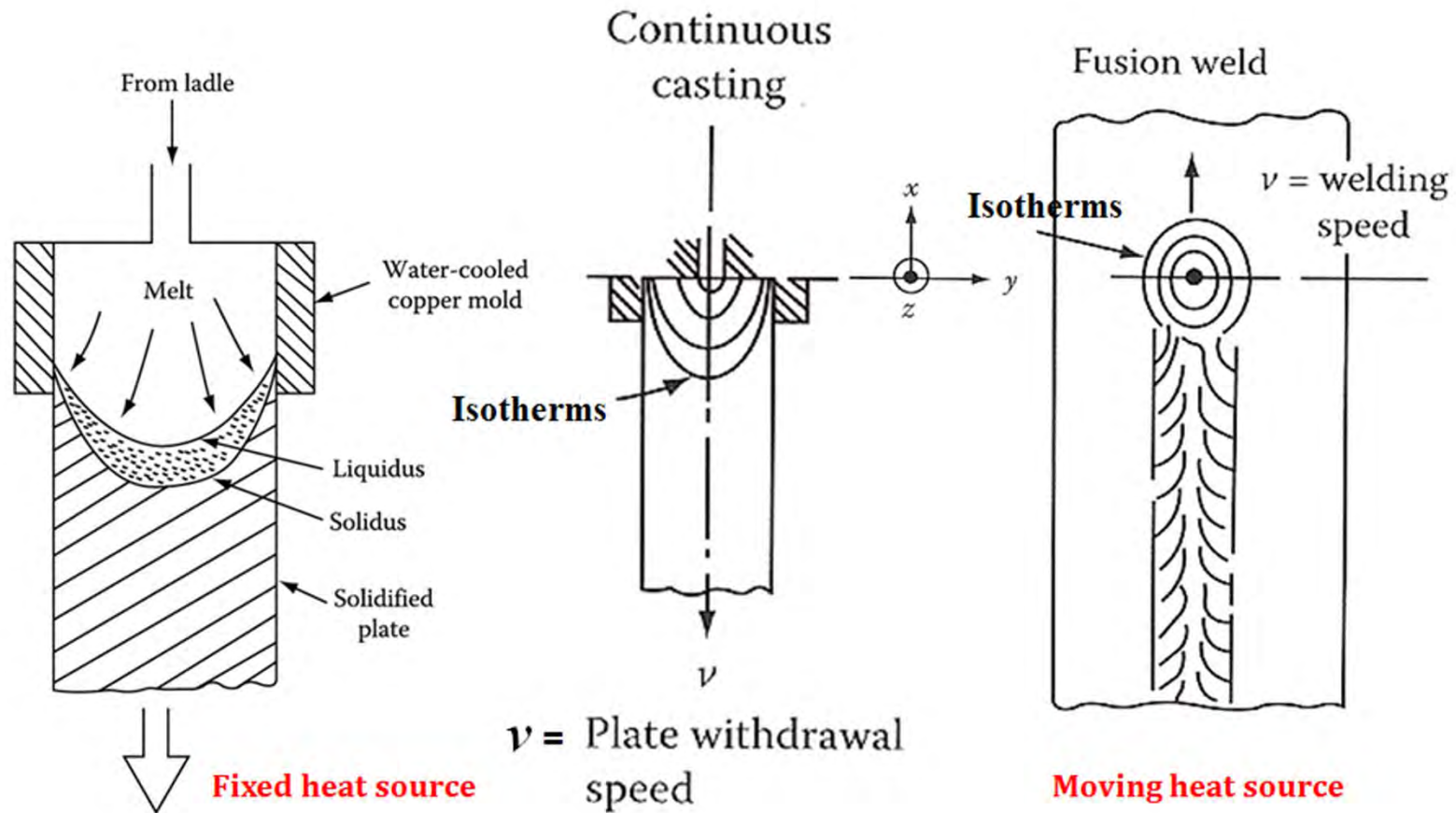


Fig. 4.44 Schematic illustration of a continuous casting process

Fig. 4.45 Illustrating the essential equivalence of isotherms about the heat sources in fusion welding and continuous casting 10

# continuous casting: a number of dynamic industrial process

② temperature gradient is maintained in a steady state → related to constant shape of the interface and the solidification rate (here, the solidification rate is changed by not to time but to position from the surface)

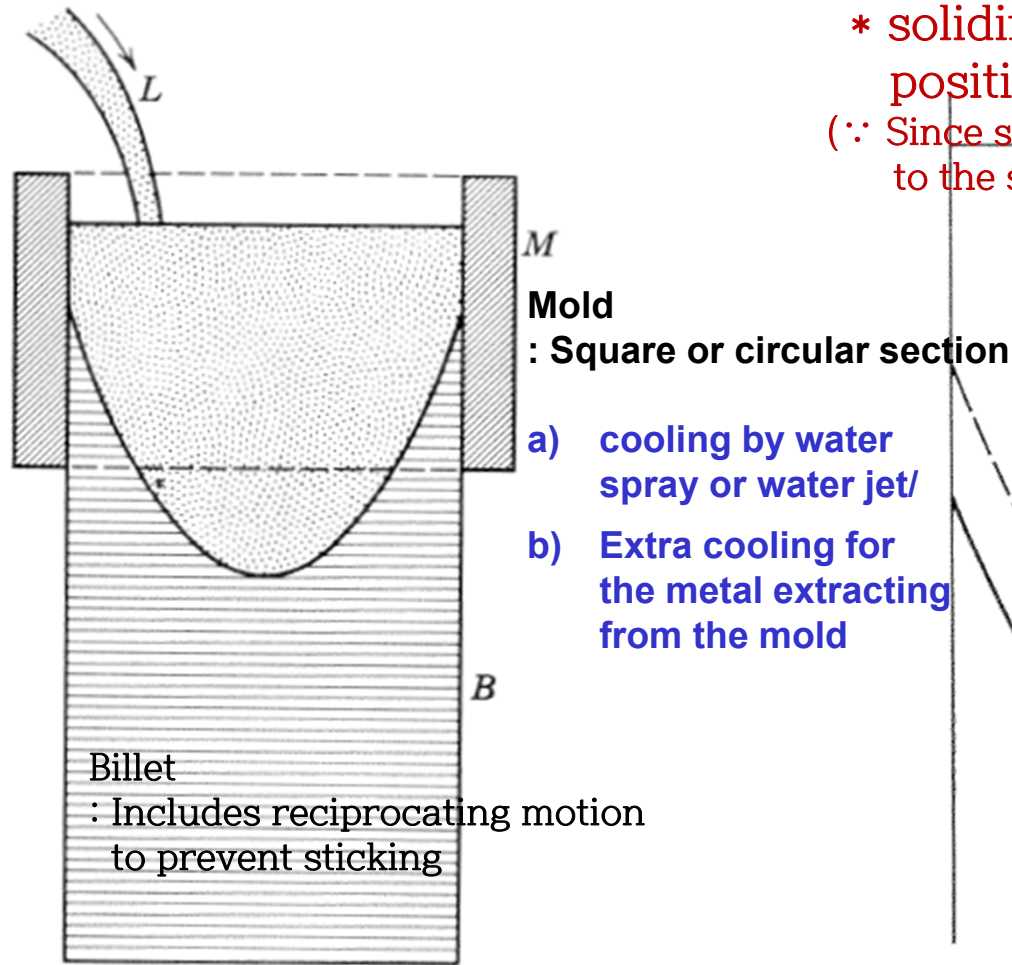


Fig. 7.5. Continuous casting (schematic).

\* solidification rate varies depending on the position as shown in the following figure  
 (∵ Since solidification occurs in a direction perpendicular to the solidification interface)

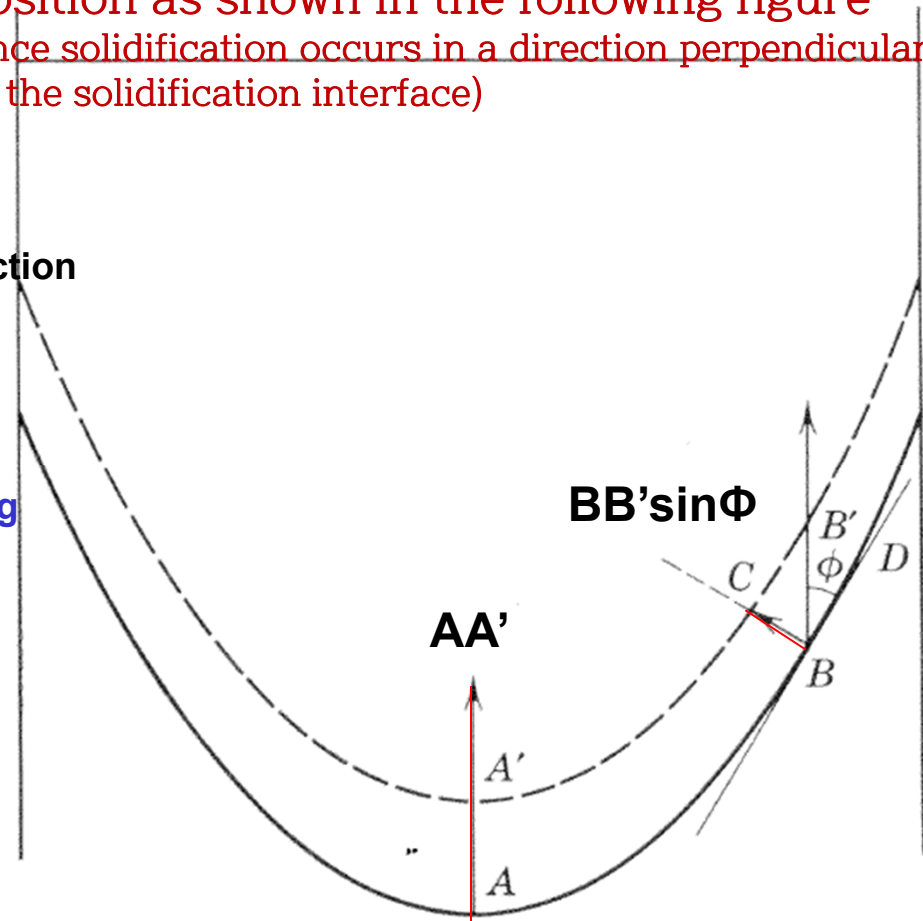


Fig. 7.6. Interface shape and rate of solidification in continuous casting.

- \* To obtain the interface shape of Fig. 7.6,  
in the case of max. emission of latent heat at A/  
min. emission of latent heat at D
- For this, efficient cooling of the billet beyond  
the mold is necessary.
  
- \* To obtain solid-liquid interface shape of Fig. 7.7,  
At the billet center, the solidification rate  
becomes minimum.
- In this case. a large tendency of segregation and porosity  
by shrinkage in the center line where solidification ends
- additional cooling of the lower part of the mold is required

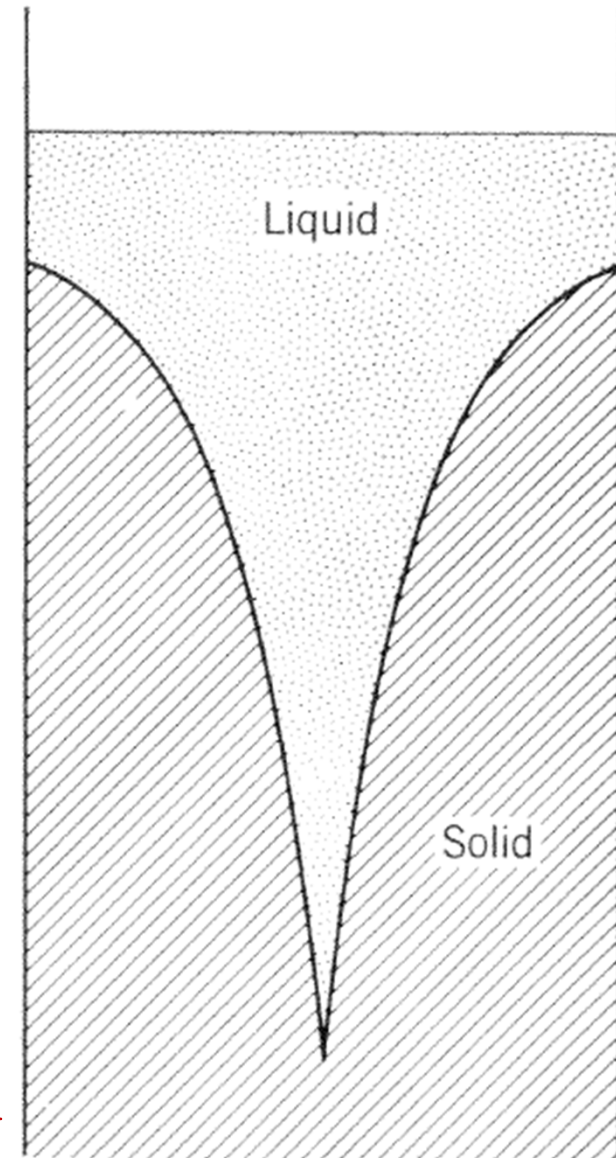


Fig. 7.7. Alternative interface shape in continuous casting

## \* Quantitative aspects of continuous casting

### ① depth of liquid core $h_c$ :

$$h_c = \frac{I\gamma R^2 v_c}{4K(\theta_f - \theta_s)}$$

where  $I$  = latent heat plus heat extracted, for unit mass, during fall of temperature from  $\theta_f$  to  $(\theta_f + \theta_s)/2$

$\gamma$  = density

$R$  = radius of billet (assumed cylindrical)

$v_c$  = rate of withdrawal of the billet

$K$  = thermal conductivity of the solid metal

$\theta_f$  = melting point

$\theta_s$  = surface temperature (assumed uniform)

(1) Depth of core for billets of equal diameter  $\propto$  casting rate ( $v_c$ )

(2) Depth of Liquid core  $\propto$  (billet dia.)<sup>2</sup>

(3) For billets of a given diameter and a given alloy composition,

limiting rate of solidification  $v_l$

$$v_l = \frac{4K(\theta_f - \theta_s)}{I\gamma R}$$

→ **The existence of this limit follows from the consideration that as casting velocity  $\uparrow$  → length of liquid core  $\uparrow$  → changing angle  $\Phi$  → a much greater normal freezing rate is required to give the required longitudinal rates.**

→ In practice, a very long liquid core produces segregation and porosity difficulties of the kind mentioned in connection with interfaces of reverse curvature

\* Figure 7.8 shows the validity of the calculation of the liquid core depth.

casting rate  $\uparrow \rightarrow$  depth of liquid core ( $h_c$ )  $\uparrow$

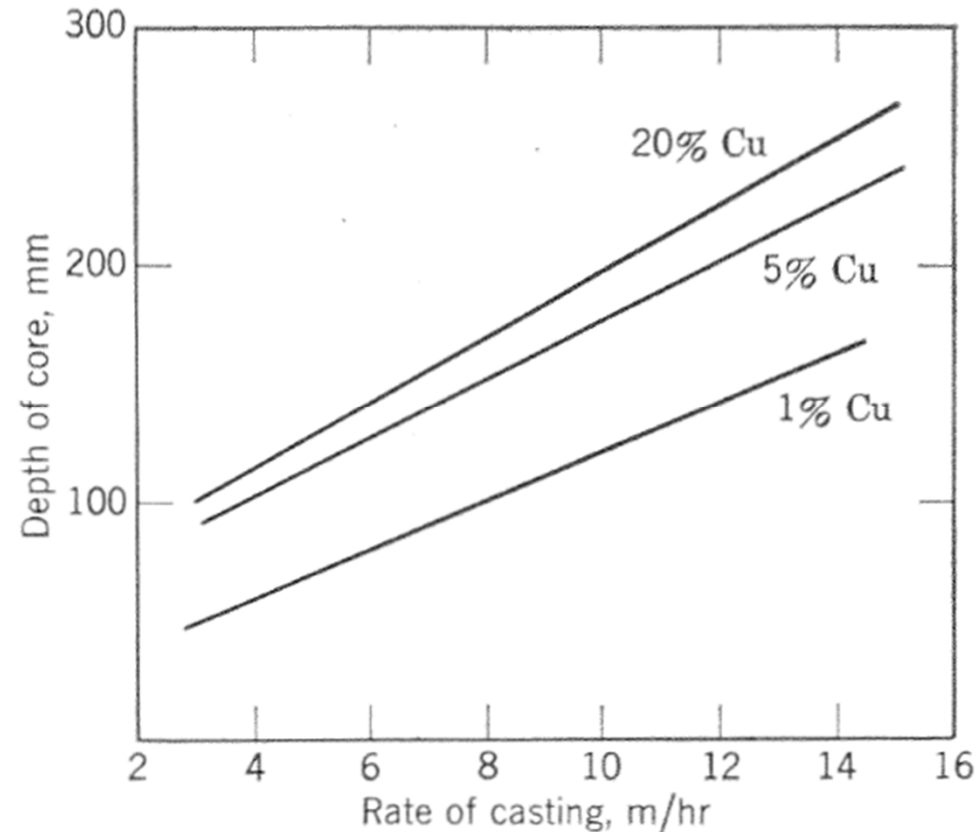


Fig. 7.8. Relationship between depth of liquid core and rate of casting.

TC Find temp. Surface temp.

$$f(h) = \frac{K(\theta_f - \theta_s)}{L + \frac{1}{2}\gamma_c(\theta_f - \theta_s)}$$

Latent heat density

is inversely proportional to the pool depth for a given combination of casting speed and billet size

\* Table 7.3 shows pool depth,  $f(h)$ , of various alloys.

Metal	$K$	$L$	$K/\gamma^c$	$f(h)$
Aluminum	0.53	93	0.82	0.72
Copper	0.92	50	0.98	1.02
Brass	0.28	37	0.33	0.36
Mild steel	0.11	78	0.09	0.10

→  $f(h)$  steel <  $f(h)$  Al → pool depth of steel >> pool depth of Al

① A very long liquid pool increases the danger of the liquid breaking out through the solid skin (Strong solid skin is required to withstand the hydrostatic pressure induced by the liquid head at the liquid interface/ more important when <Speed ↑>) limiting speed or cross section for continuous casting of steel is much less than for other metals due to low  $f(h)$

② Billet size ↑ → liquid pool depth ↑  
 → The billet can not be cut until the liquid area is completely solidified  
 → a very long device is needed for high speed casting

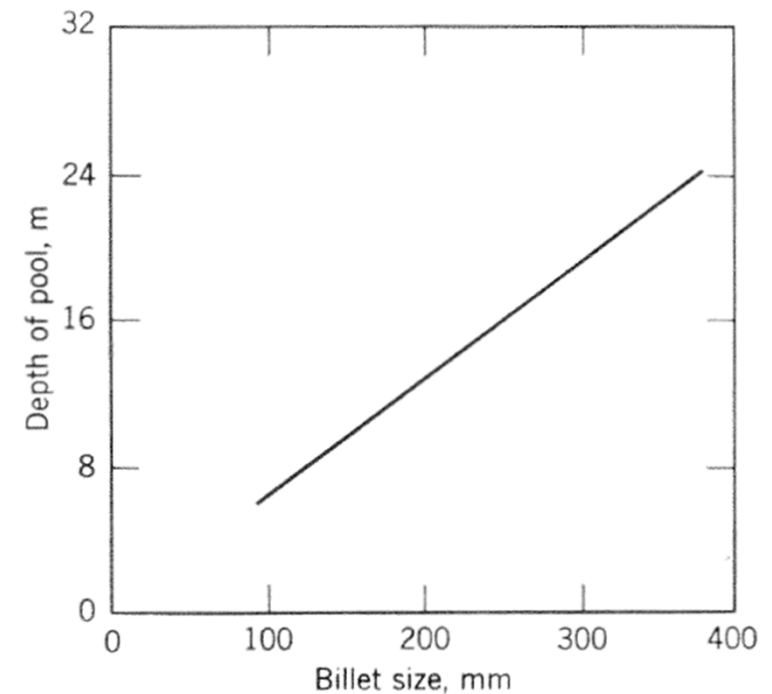
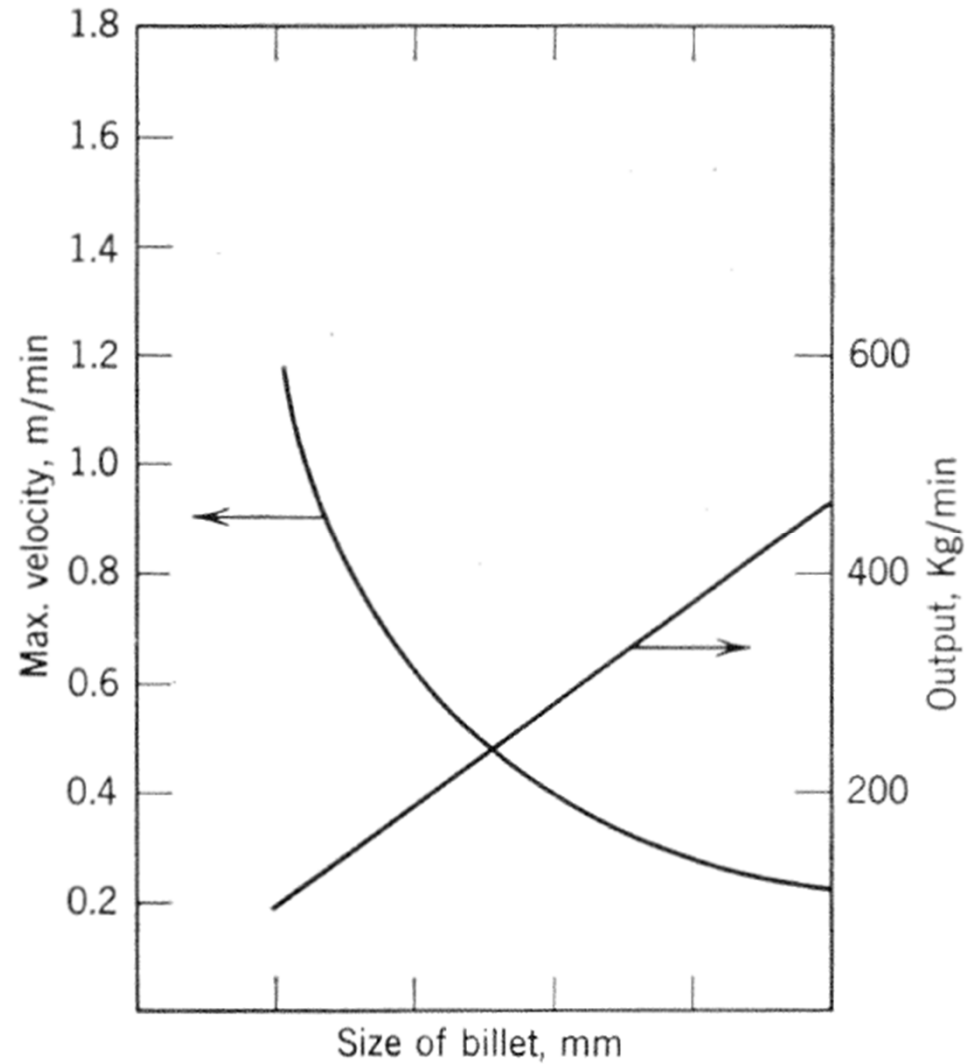


Fig. 7.9. Pool depth for continuously cast steel billets as a function of billet size.

- ③ By theoretical considerations a) Increasing the cross section size of the billet is obtained by slower solidification / b) Increasing output is obtained by increasing cross section size.



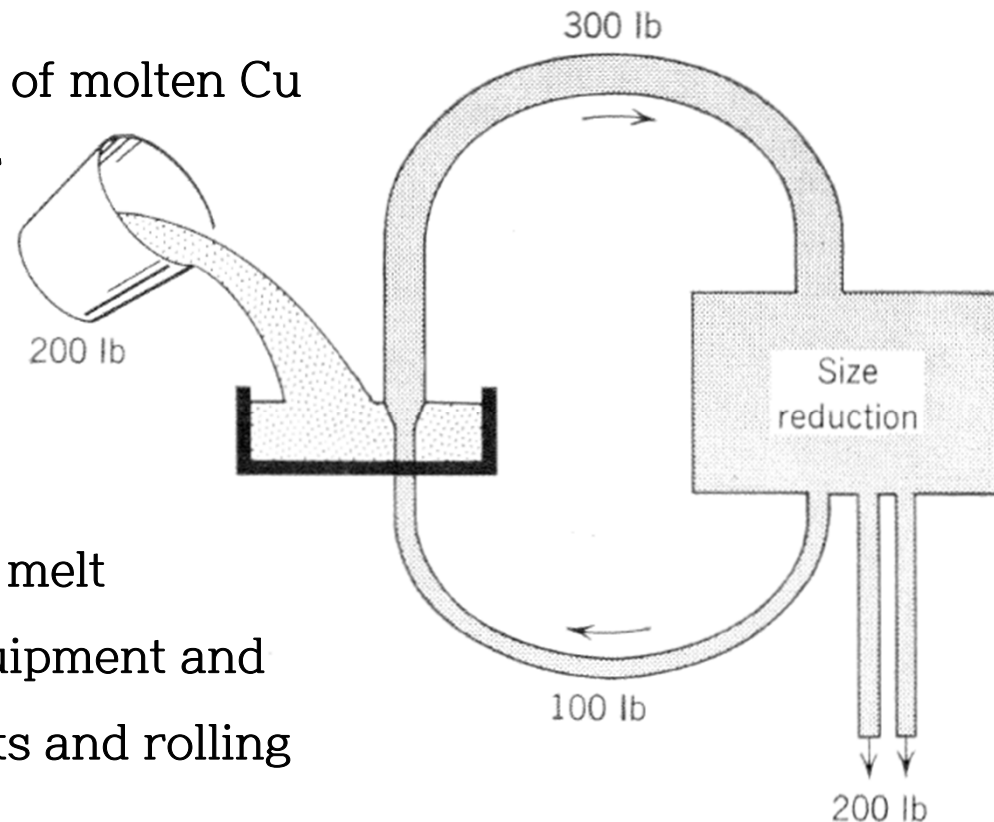
7.10. Maximum casting speed and output per unit time as a function of bullet size.



### 3. Dip forming: 2<sup>nd</sup> type of continuous casting

: the amount and shape of solidified metal is controlled by a heat sink rather than by a mold/ developed for fabrication of Cu rod: Cu rod (cold when it enters) → heated up by the bath & some of which solidifies on the rod → increase of thickness

100 lb rod → pass through a bath of molten Cu  
=300 lb rod → 1/3 of it is used for further dip forming (100 lb rod)/  
2/3 200lb rod\_ready for further processing



- ① Direct production of rod from melt
- ② high speed, eliminating the equipment and time required for pouring ingots and rolling them into rod

7.11. Principle of dip forming.

# Dip Casting

- Dip a part or mold into liquid resin
- Resin can be it's own part (gloves) or it can be a portion of a larger part



## \* Calculation of thermal factor for Dip forming

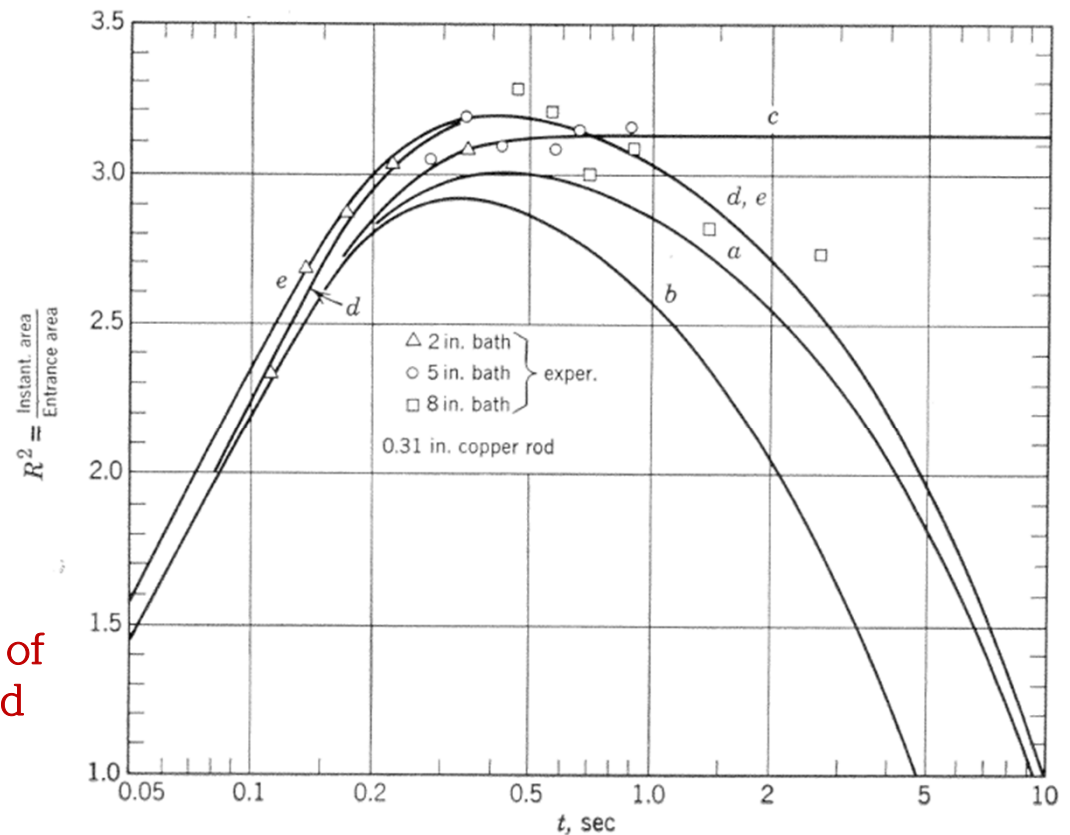
- ① thickness of added metal  $\sim f$  (time in bath melt, speed of bar, temperature, thermal property, geometry of the system)
- ② amount of added metal  $\sim$  if depth of the bath is sufficient, increase to max. and then decreases

Fig. 7.12 shows some experimental points (for speeds ranging from 15 ft/min to 90ft/min & bath temp. of about and theoretical curves using different values of the effective temp. of the bath and the rod.

→ Calculation and experimental  
: good similarity

But calculations are made on the assumption of a smooth interface. This condition would be satisfied in the case of pure Cu, but when the process is applied to an alloy, a dendritic or cellular-dendritic interface is to be expected.

$\therefore$  Max. amount solidified would be somewhat greater for an alloy



7.12. Comparison of experimental and theoretical results of dip forming of copper.

## 7.4. Thermal stresses in a solidifying Body

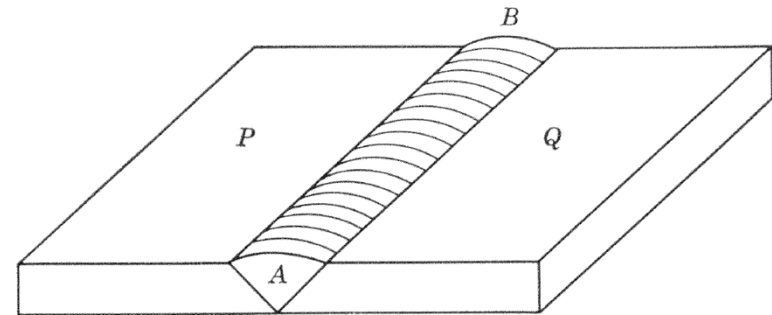
: Effect of macroscopic heat flow → Temperature gradient in the solidified metal  
during solidification → different contraction of the solid metal

→ thermal stresses within the solid metal ↑

### ① Extreme case : welded joint

: Unless the plates are pre-heated, the “bead” contracts far more, after it is solid, than do the plates, and high stresses are in a welded joint between two metal plates.

→ Plastic deformation may relieve the stresses, but cracking often occurs instead.



7.13. Origin of stresses in a weld.

### ② stress arises as a result of contraction of solidified metal

: if an alloy solidifies over a long temperature range, the contraction of the first part to solidify may tear the metal apart where there is still some liquid, resulting in extreme weakness, although the casting may appear to be sound.

→ “hot tearing”

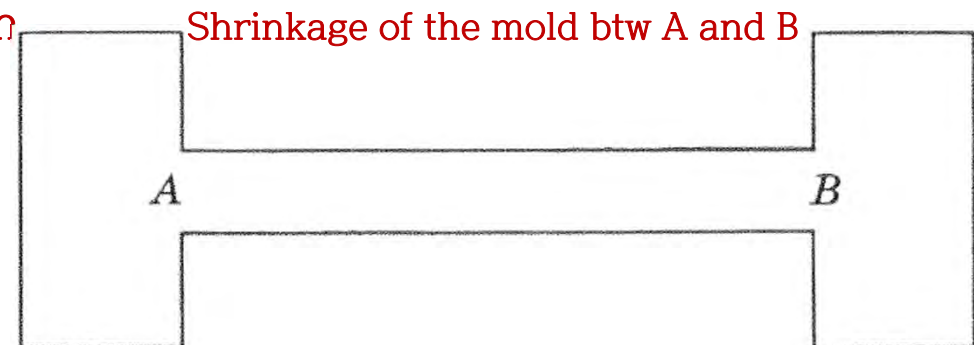


Fig. 7.14. Origin of contraction stresses in a casting.

# 8. The Structure of Cast Metal

## 8.1. General Consideration

- \* “Structure” of cast metal
  - ① **metallographic sense**  
: Size, Shape, Orientation and perfection of the crystals
  - ② **Distribution in the metal of the various chemical elements**  
: macro- and micro-segregation
  - ③ **Internal and external topography of metal**  
: Porosity, soundness, surface shape, and finish

→ Main variables: “**chemical composition**” & “**solidification rate**”  
Gasses/ impurity/ elements      Different parts of metal freeze at different rates/ liquid metal may not be stationary during solidification

→ Three main categories for solidification

“Casting” ↔ “Ingots and Billets” ↔ “Cast metal with a more complicated structure”

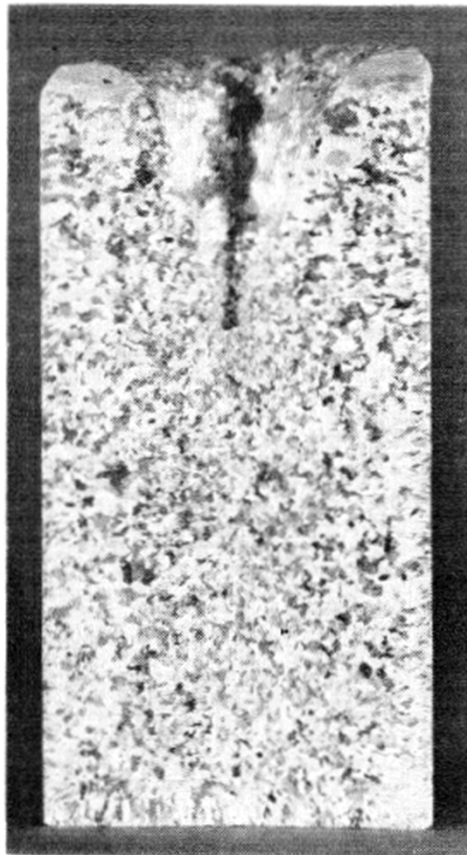
Welds, brazed and soldered joints  
and hot dipped and sprayed coating

- 1) casting: the structure that is produced by the solidification process is preserved, which may followed by further heating like homogenization**
- 2) Ingots & billets: the structure formed during solidification is changed by subsequent deformation and annealing; this produces an entirely new grain structure but it does not completely cure either porosity or segregation**

## 8.2. The macrostructure of cast metals

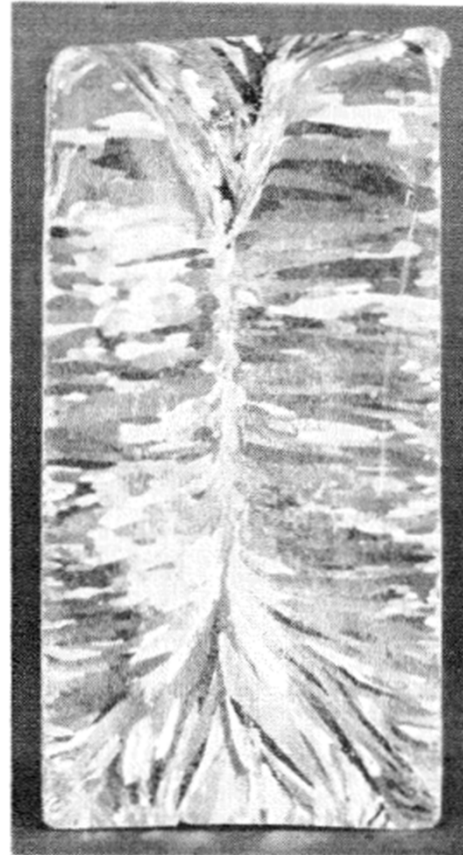
### a. Description of cast structure

→ Main factors: heat release rate, amount of metal, composition, amount of nucleus



(a)

Metal & cooled rapidly of small mass → large # of equiaxed crystals → “casting structure”



(b)

Metal & cooled slowly of large mass → Columnar growth perpendicular to mold wall



(c)

Partially columnar structure → “Ingot structure”

Fig. 8.1. “As cast” structures. (a) Completely equiaxed, (b) Completely columnar, (c) partially columnar.

\* When columnar and equiaxed crystals begin to dendritically grow, they develop into cellular dendrite (Fig. 8.2): Control of degree of formation btw two microstructures  
→ Main process variables: “metal”\_ composition, nucleation characteristics, temperature when it is poured, its motion as it enters the mold, “mold”\_ thermal property of mold, temperature, and geometry

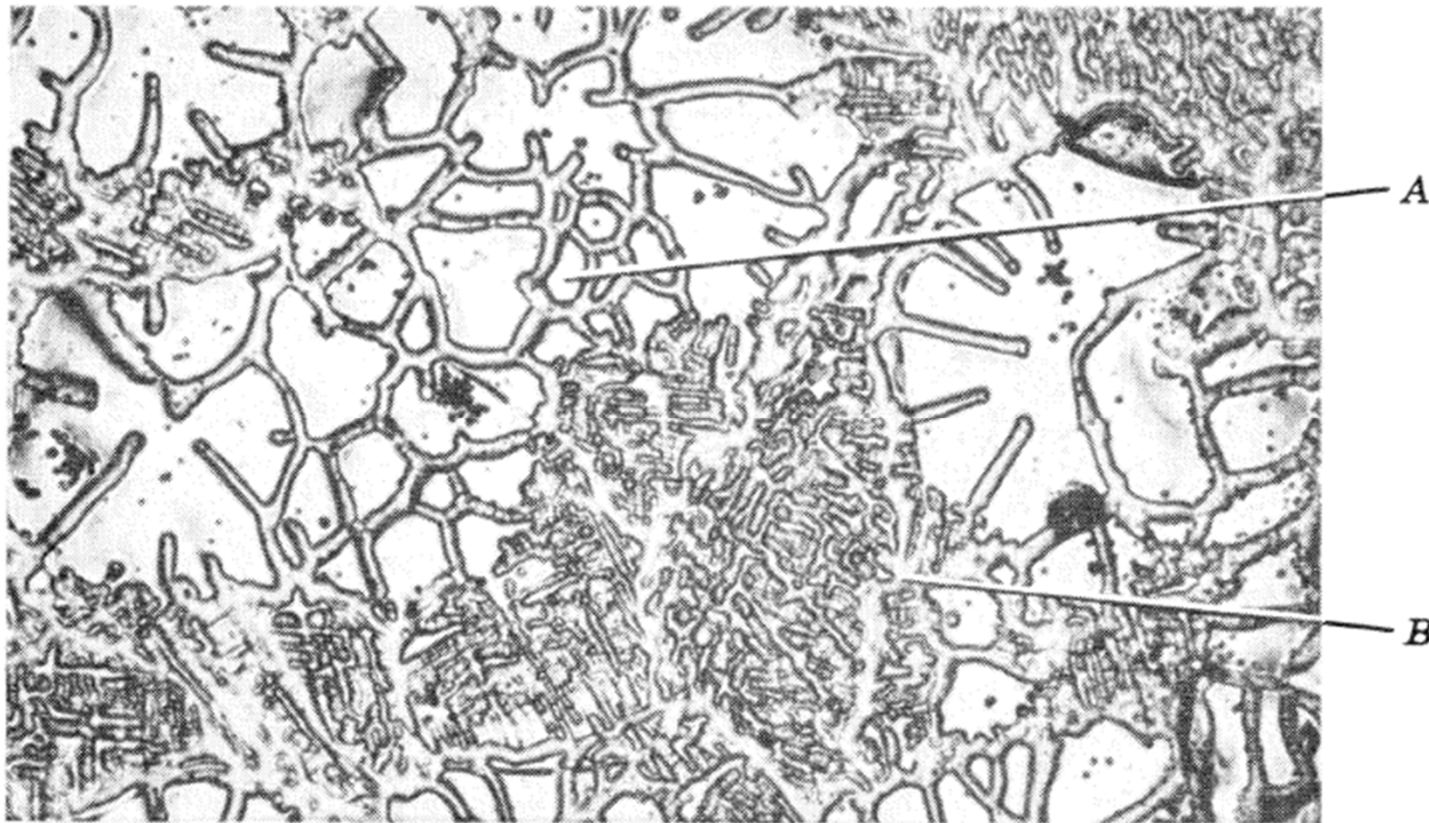


Fig. 8.2. Equiaxed grain in an ingot of Al-2% Cm, showing pre-dendritic region (A) and cellular dendritic region.

b. Experimental observation: Effect of process variables for controlling structure

→ Au-Cu alloy + graphite mold (3 inch height/ 2 in diameter)

Columnar length and Equiaxed grain size measurements at different pouring temperatures

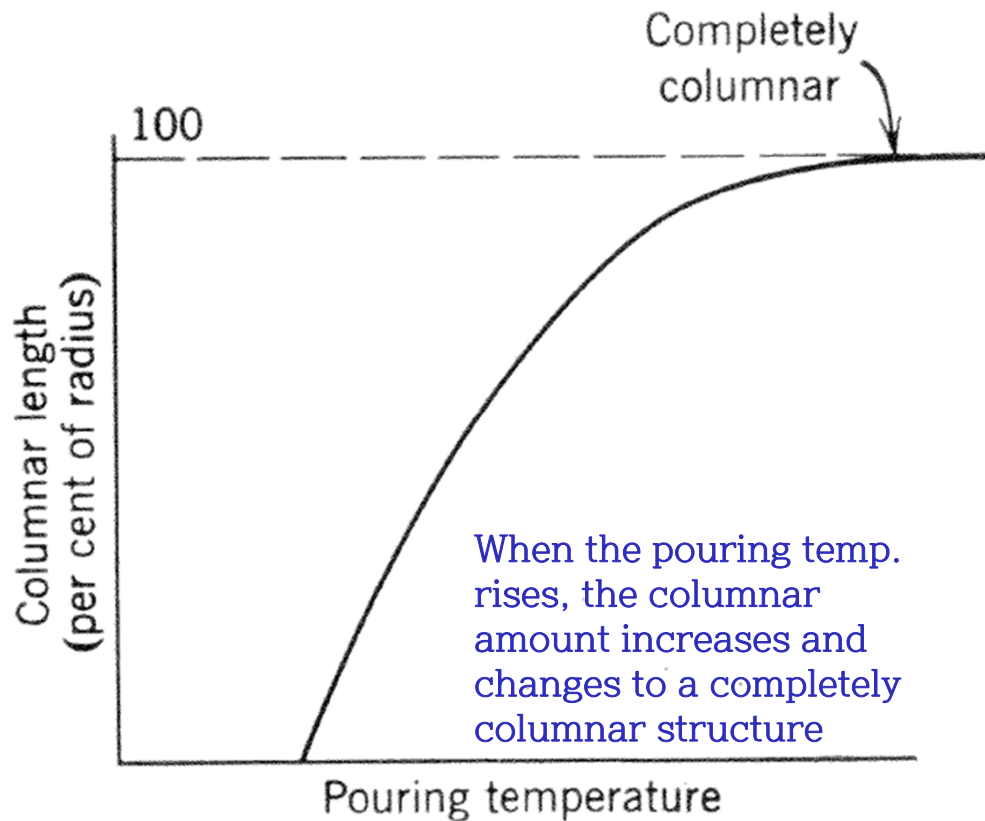


Fig. 8.3. Variation of length of columnar zone with pouring temperature.

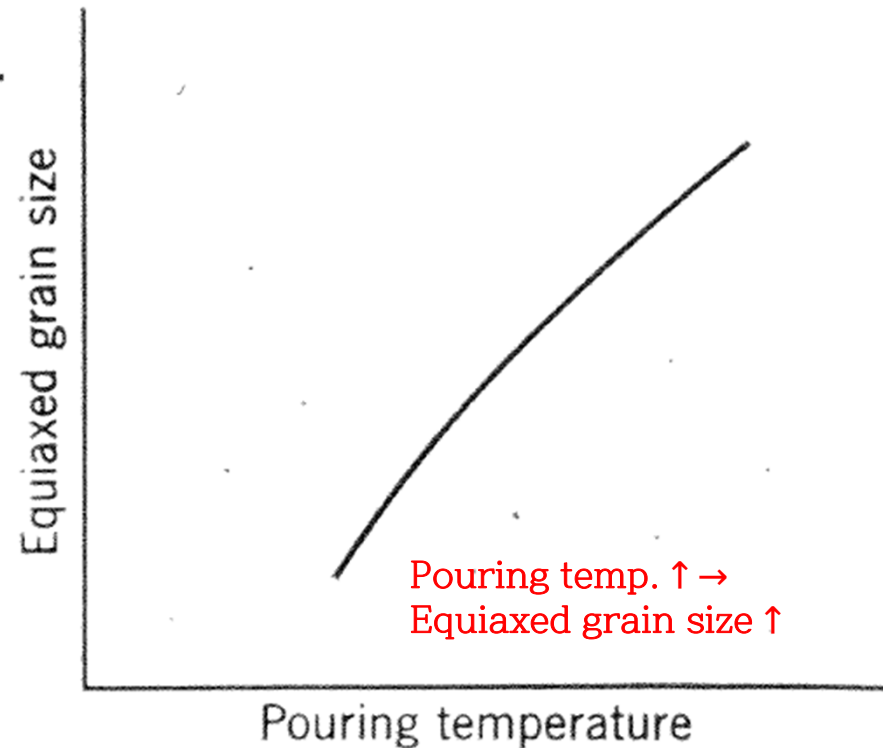


Fig. 8.4. Variation of equiaxed grain size with pouring temperature.



b. Experimental observation: Effect of process variables for controlling structure

→ Au-Cu alloy + graphite mold (3 inch height/ 2 in diameter)

Columnar length and Equiaxed grain size measurements at different pouring temperatures

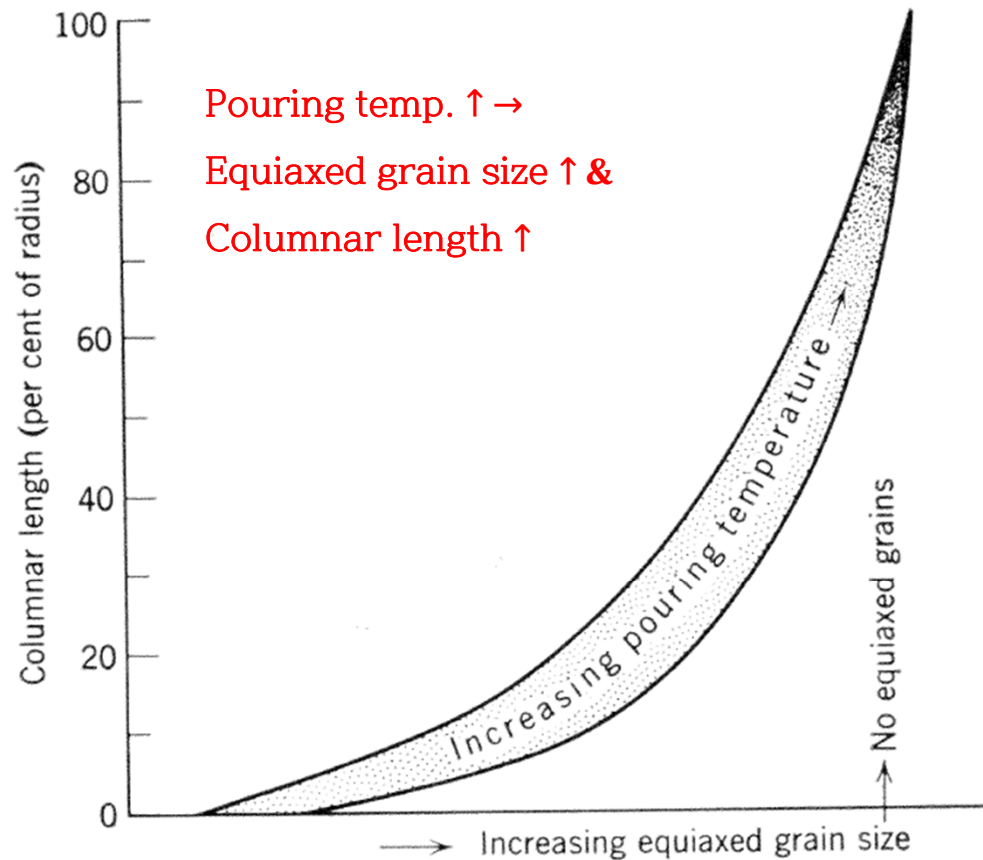


Fig. 8.5. Variation of equiaxed grain size with columnar length.

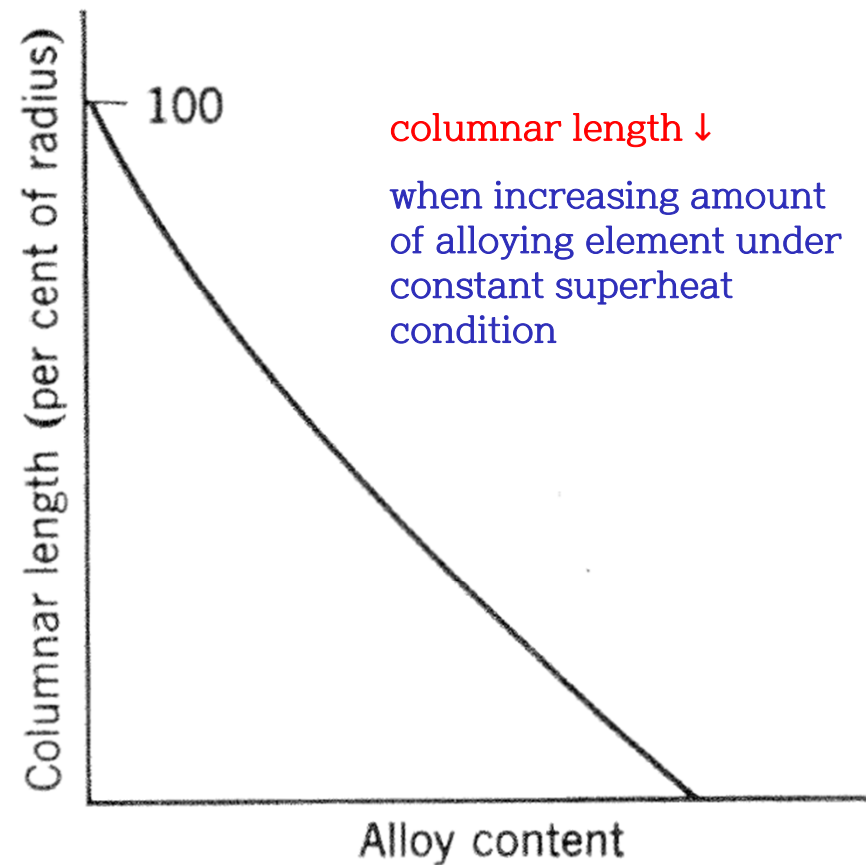


Fig. 8.6. Variation of columnar length with alloy content; constant superheat.

## c. Solidification in a mold

### (1) Chill zone

- When the molten metal is poured into the mold, nucleation increases due to  $\Delta T$  of the mold wall and melt  $\uparrow$

→ small  $\Delta T$  → slow growth of nuclei → easy extra nucleation

large  $\Delta T$  → fast growth of nuclei → difficult extra nucleation

\* Crystal # in chill zone  $\propto$  the availability of nucleants, the rate of heat release, the volume of chilled liquid, the temperature of the metal surface when metal reaches  $T_l$ , and the thermal properties of the mold and metal.

Ex ① **During pouring at high T, the metal is heated while the metal is chilled on the surface, reducing the rate of heat release until the nucleation temp is reached**

**high pouring temp** → # of nuclei  $\downarrow$  / **low pouring temp** → # of nuclei  $\uparrow$

Ex ② **Metal with high thermal diffusivity & metal with low thermal diffusivity** :

**heat release  $\uparrow$  → More nucleation density in larger liquid volumes**

Ex ③ **Composition:** Excess solute rejection from Alloy → Decrease dendrite growth rate in given supercooling → Alloying element  $\uparrow$  → Increase nucleation

## c. Solidification in a mold

### (1) Chill zone

\* Just after nucleation: Not all nuclei are in good contact with the mold wall

→ Convection current of liquid metal

1) Low pouring temp.: Many nuclei falling off due to the mold temp. increase continue to grow due to the reduction of the melt temp. = big-bang wall nucleation → Equiaxed structure

2) High pouring temp.: Most of the separated nuclei are re-melted and form a chilled zone on the mold wall

\* Initial solidification: Pre-dendritically grow in chilled zone → Residual liquid rapidly drops to Sol.-Liq. temp. of the crystal growing in the superheated state.

1) If this temperature is above the nucleation temperature of the melt → No extra nucleation → ingot type structure

2) If this temperature is below the nucleation temperature of the melt → extra nucleation in whole melt → casting type structure

## (2) Columnar zone: Produced as a result of heat flow towards mold

→ Fast growth rate with preferred orientation & obstructing growth by forming branches

\* The interface between the columnar crystal and liquid forms smooth, cellular, cellular-dendritic structures (most alloys) depending on alloy composition and solidification rate

\* Favorable orientation: Perpendicular to mold wall

FCC, BCC →  $\langle 100 \rangle$  direction/ HCP →  $\langle 10\bar{1}0 \rangle$  direction

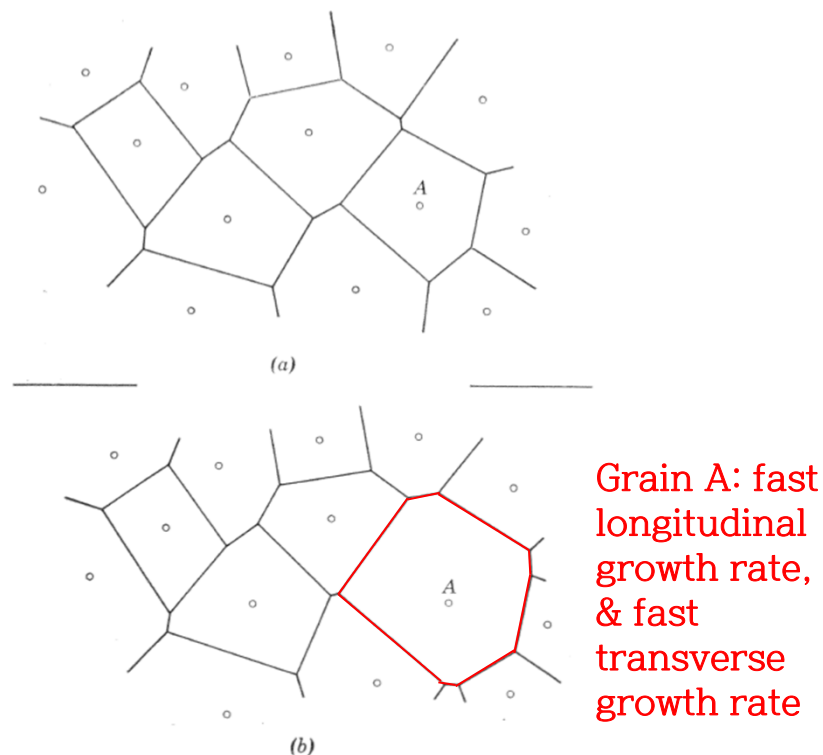


Fig. 8.7. Shapes of crystals growing from randomly selected points. (a) Equal rates, (b) crystal A growing twice as fast as the others.

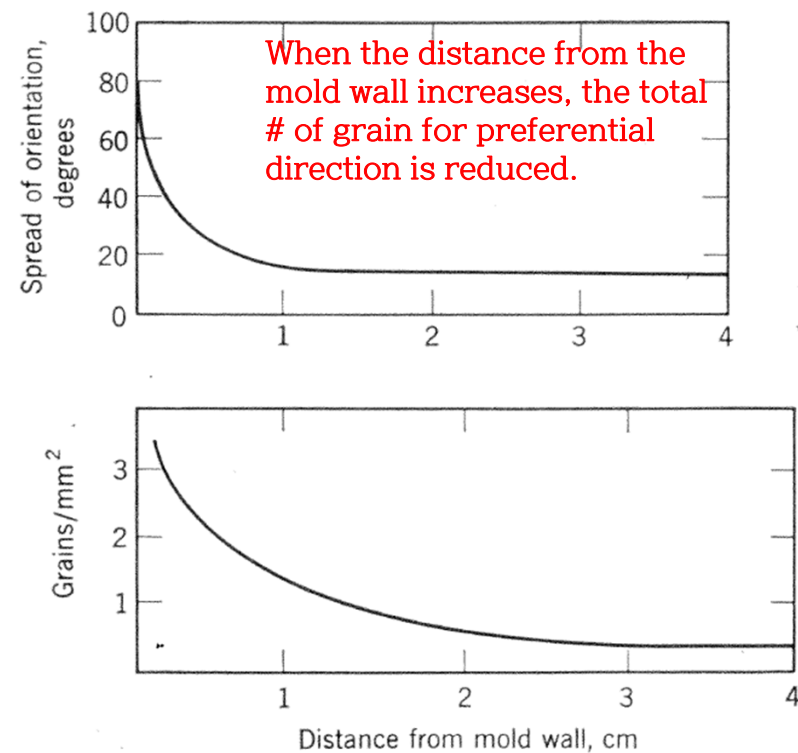


Fig. 8.8. Variation of grain size and preferred orientation with distance from mold wall.

**(2) Columnar zone:** Produced as a result of heat flow towards mold

→ Fast growth rate with preferred orientation & obstructing growth by forming branches

\* Boundaries near the mold corner

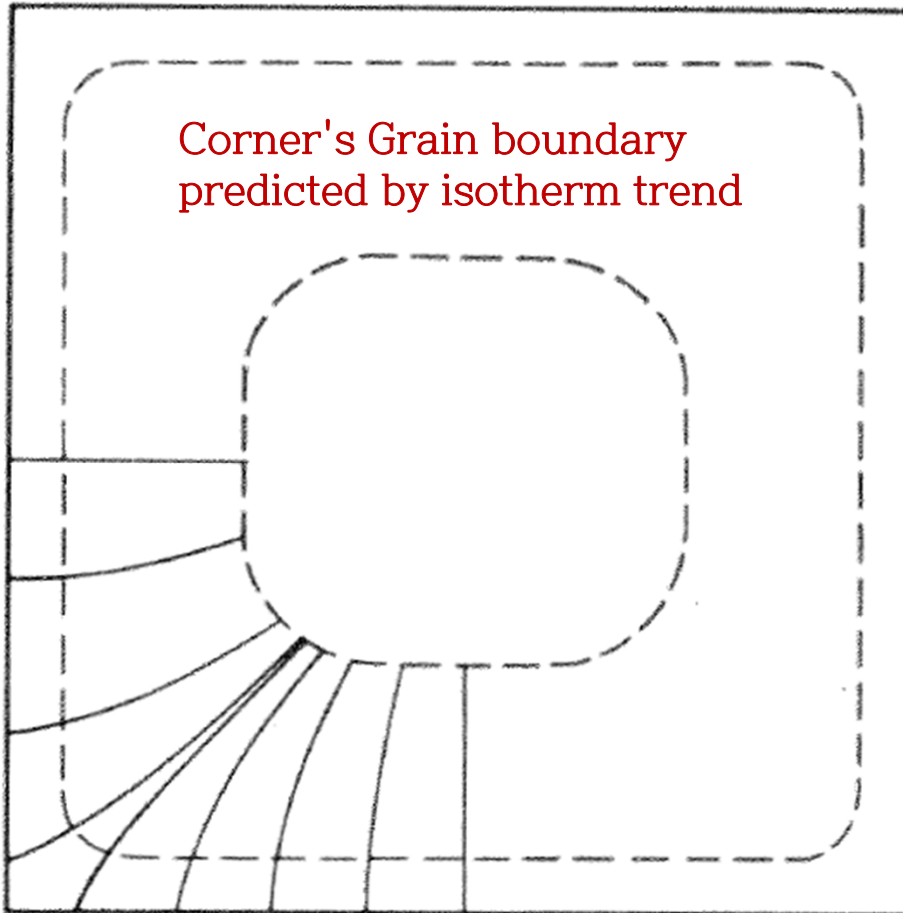


Fig. 8.9. Grain boundaries orthogonal to isotherms (schematic).

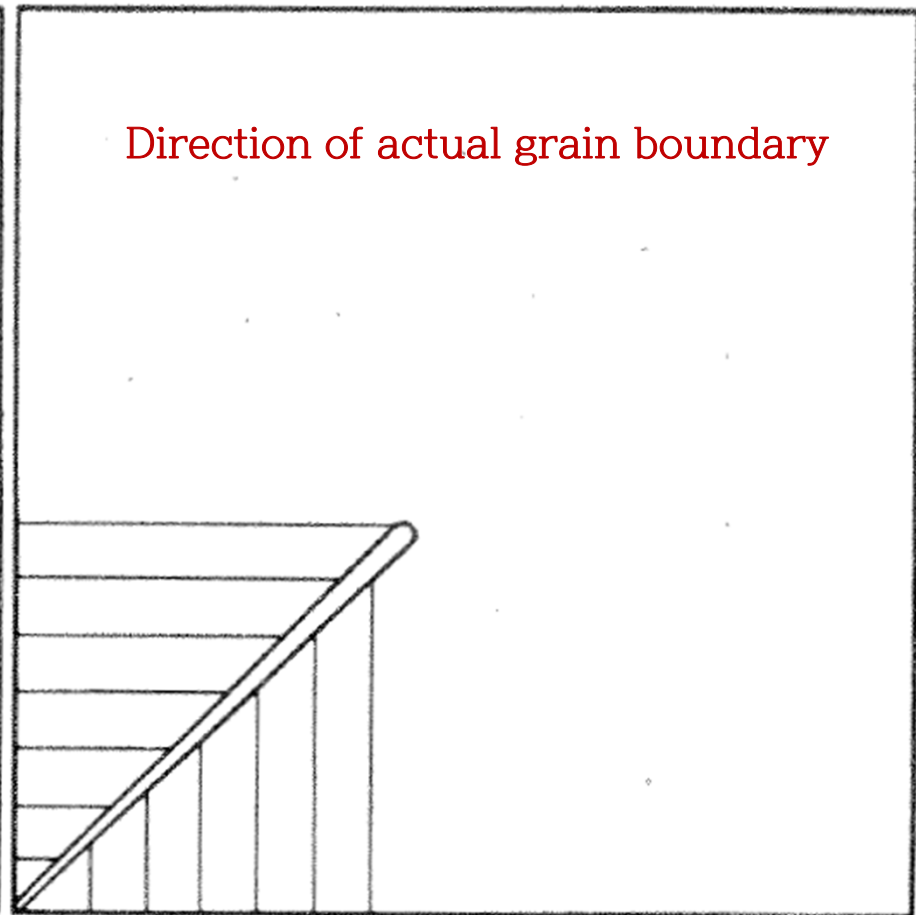
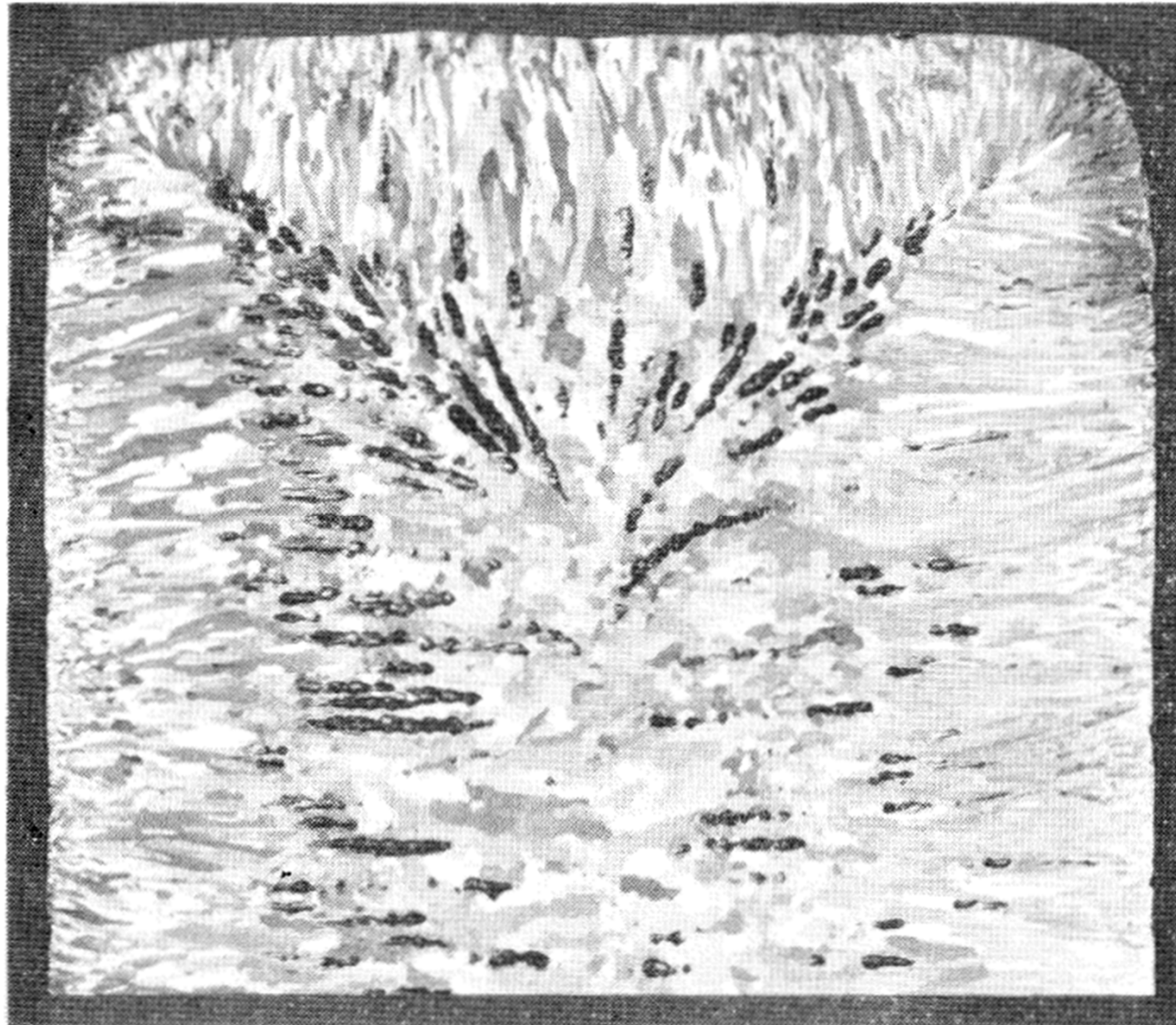


Fig. 8.10. Grain boundaries maintaining original directions (schematic).

\* Actual Photograph of structure shown in Figure (8.10)

: This structure is due to the large crystallographic orientation dependence of cellular-dendritic type growth.



\* It is considered that the nuclei of the columnar zone were all formed on the mold wall. But it is recently investigated that equiaxed crystals of pre-dendritic structure within the columnar zone as shown in Fig. 8. 12.

→ Growth of crystal fallen from cold mold wall.

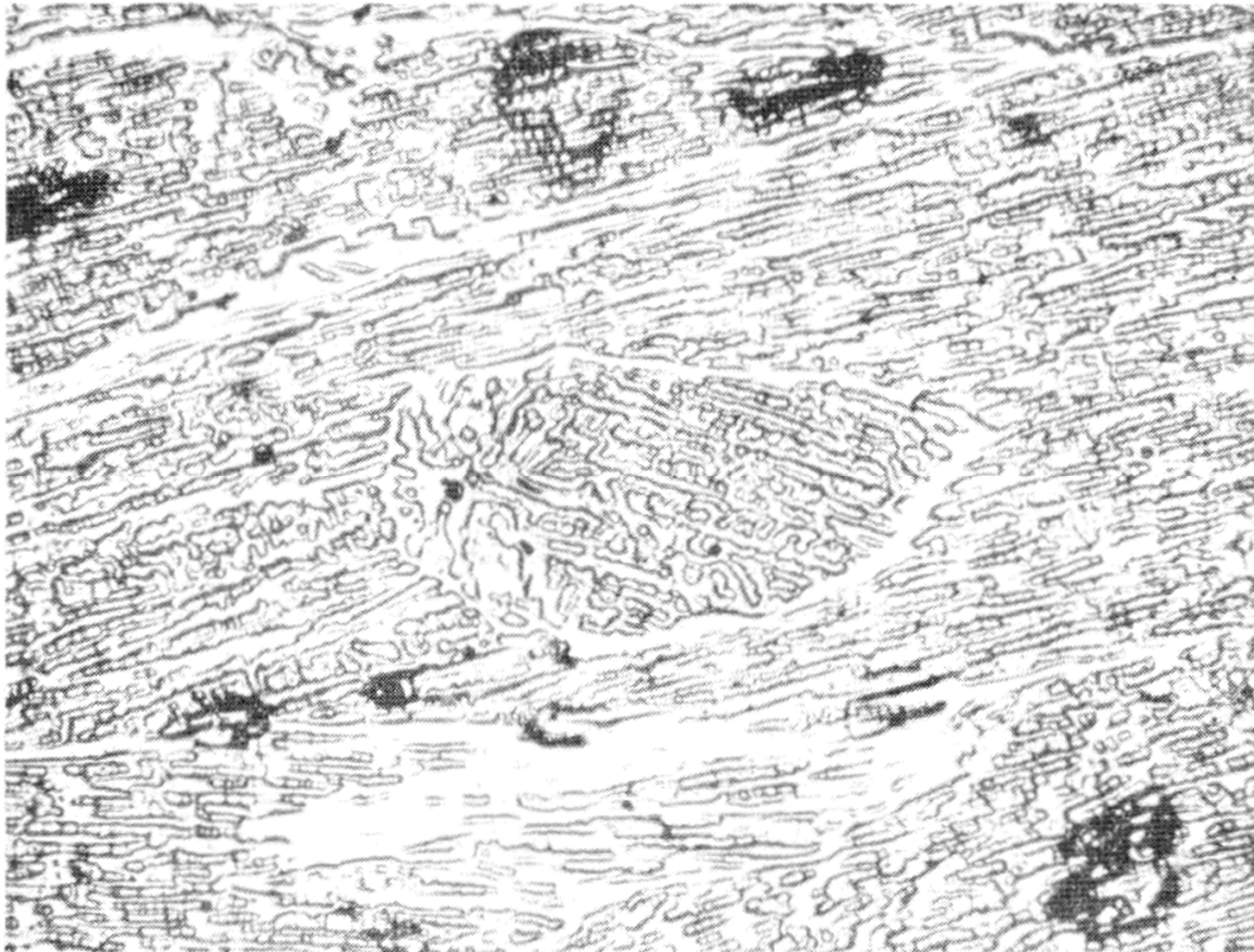
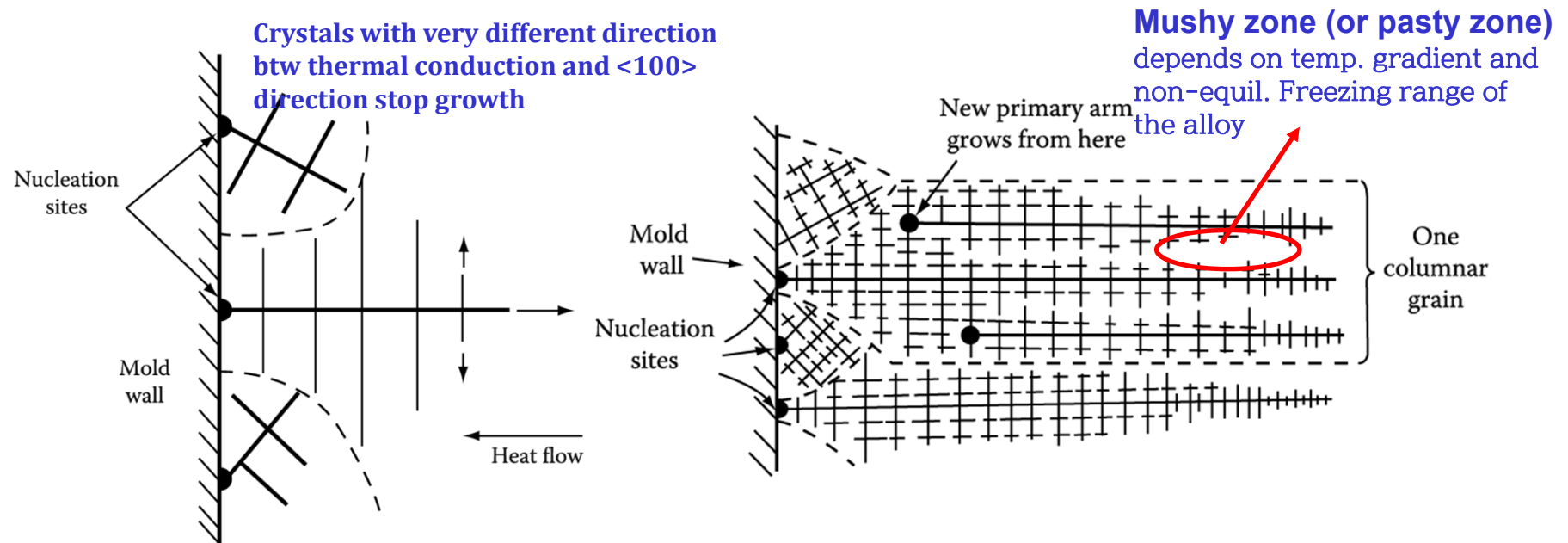


Fig. 8.12. Equiaxed crystals in columnar zone.

## (2) Columnar zone

After pouring the **temperature gradient** at the mould walls **decreases** and the crystals in the chill zone grow dendritically in certain crystallographic directions, e.g. **<100>** in the case of cubic metals.

→ **grow fastest and outgrow less favorably oriented neighbors**



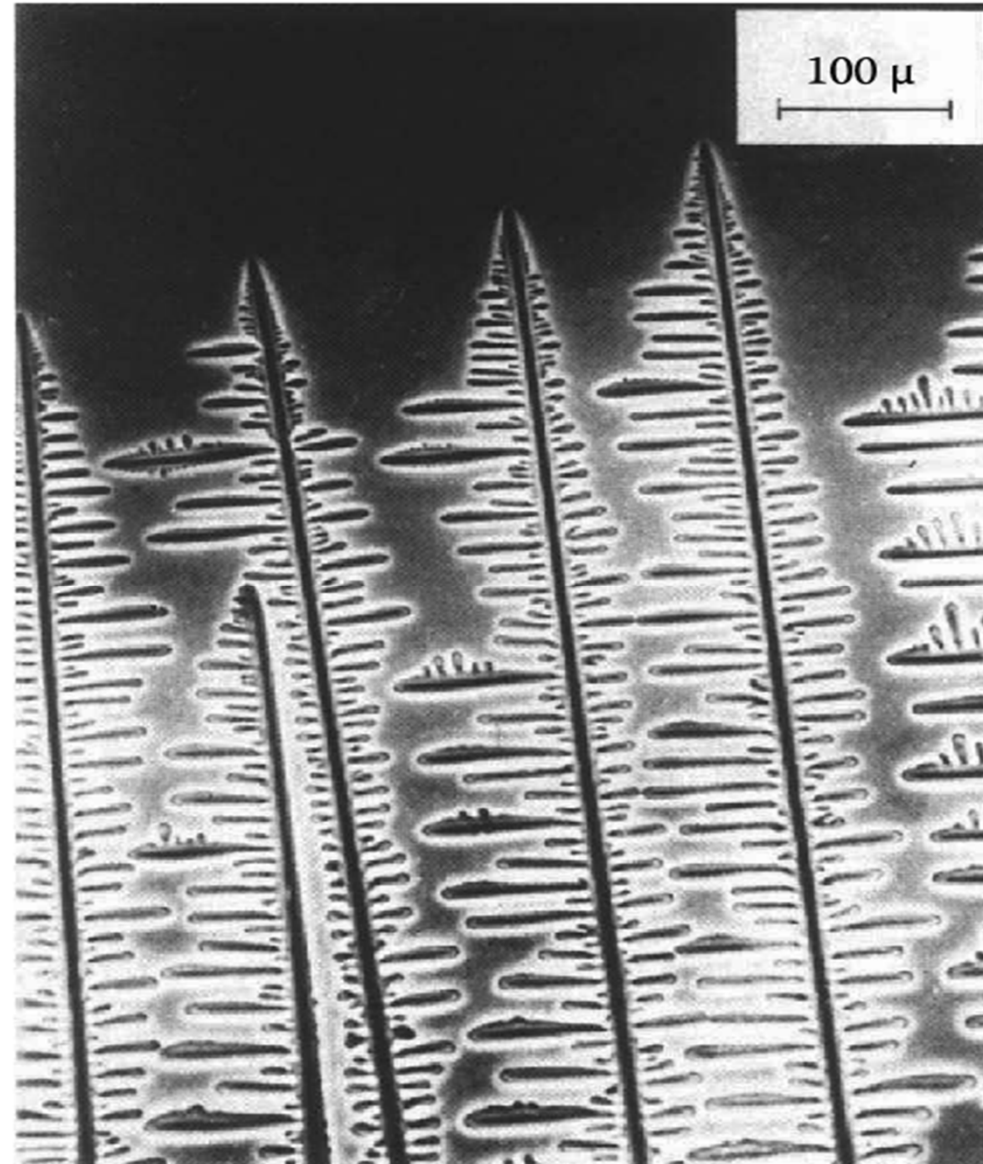
**Fig. 4.41 Competitive growth soon after pouring. Dendrites with primary arms normal to the mould wall, i.e. parallel to the maximum temperature gradient, outgrow less favorably oriented neighbors.**

**Fig. 4.42 Favorably oriented dendrites develop into columnar grains. Each columnar grain originates from the same heterogeneous nucleation site, but can contain many primary dendrite arms.**



- 1) In general, the secondary arms become coarser with distance behind the primary dendrite tips.
- 2) The primary and secondary dendrite arm spacing increase with increasing distance from the mold wall.  
( $\because$  a corresponding decrease in the cooling rate with time after pouring)

→ **Mushy zone (or pasty zone)**  
depends on temp. gradient and non-equil. freezing range of the alloy

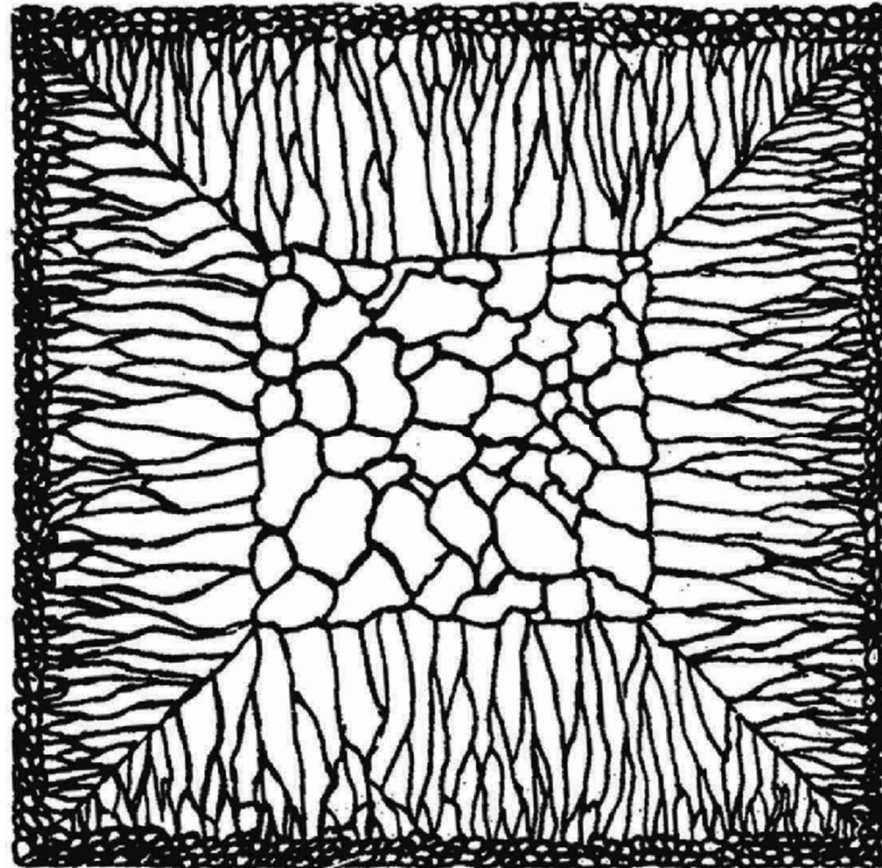


**Fig. 4.28 Columnar dendrites in a transparent organic alloy.**

(After K.A. Jackson in Solidification, American Society for Metals, 1971, p. 121.)

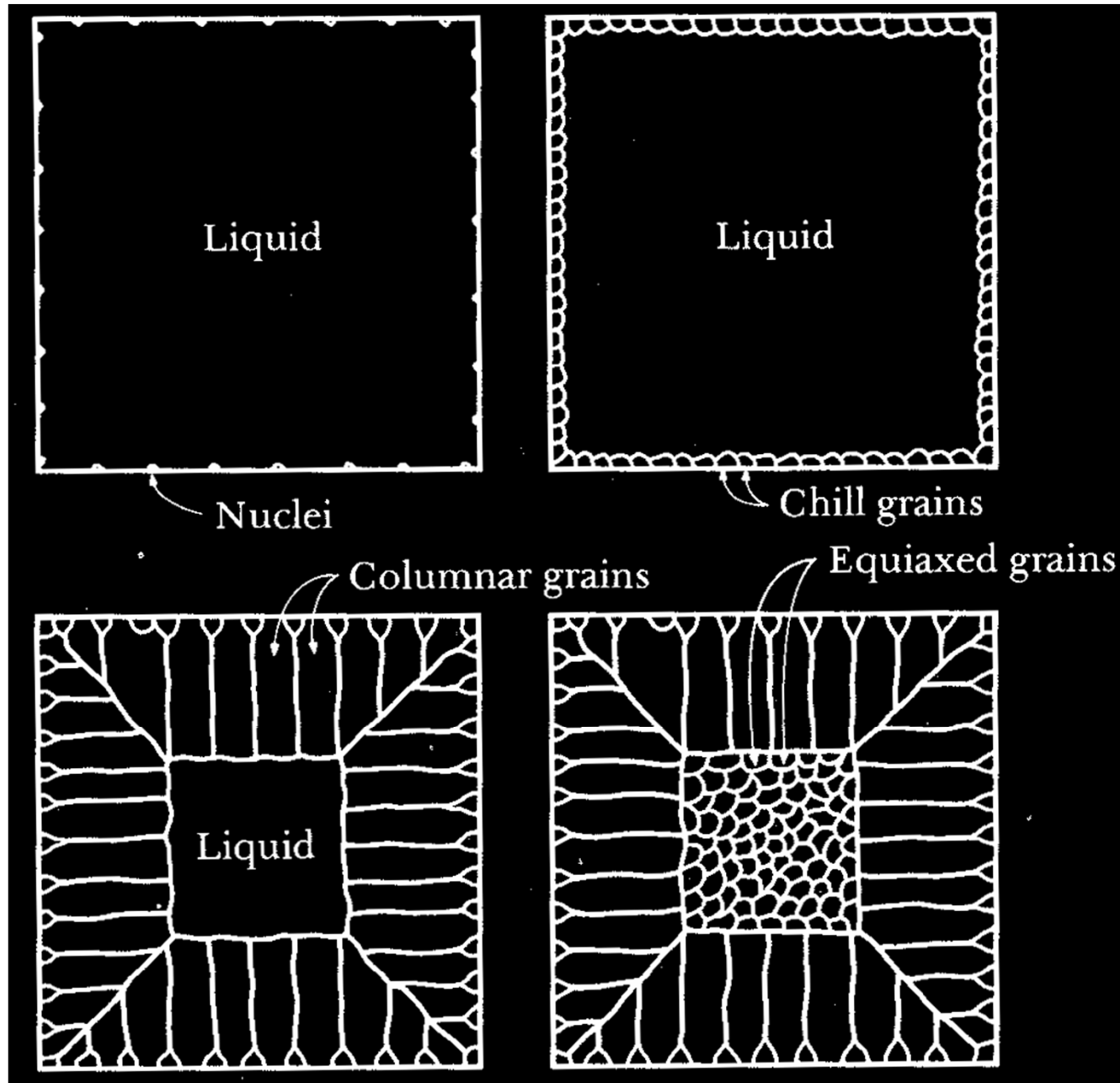
### (3) Equiaxed zone

The equiaxed zone consists of **equiaxed grains randomly** oriented in the centre of the ingot. An important origin of these grains is thought to be **melted-off dendrite side-arms + convection current**



**Fig. 4.40 Schematic cast grain structure.**

(After M.C. Flemings, *Solidification Processing*, McGraw-Hill, New York, 1974.) 34



## (4) Effect of gravity and of rotation

① Mixed structure by gravity due to “settling” of crystals

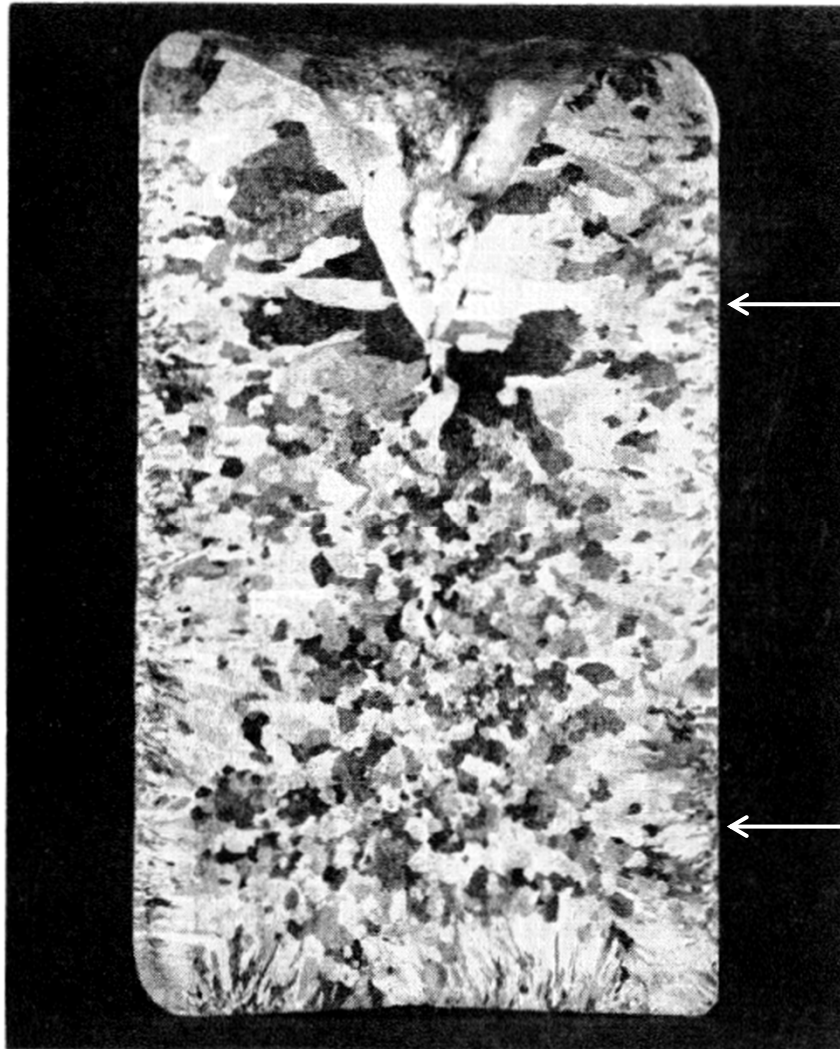


Fig. 8.16. “Mixed” structure due to “settling” of crystals.

← Columnar →

← Equiaxed →

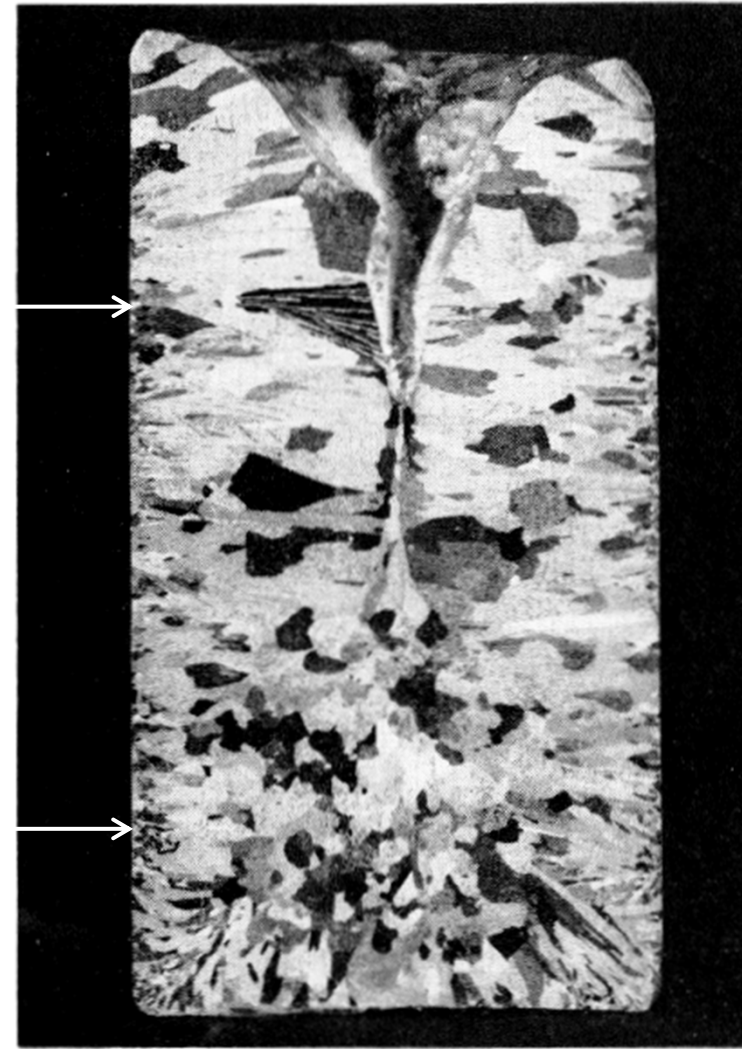


Fig. 8.17. Variation of equiaxed grain size with position in the ingot.

## (4) Effect of gravity and of rotation

### ② Melt rotation during electromagnetic stirring

a) Grain refinement and shorten columnar zone

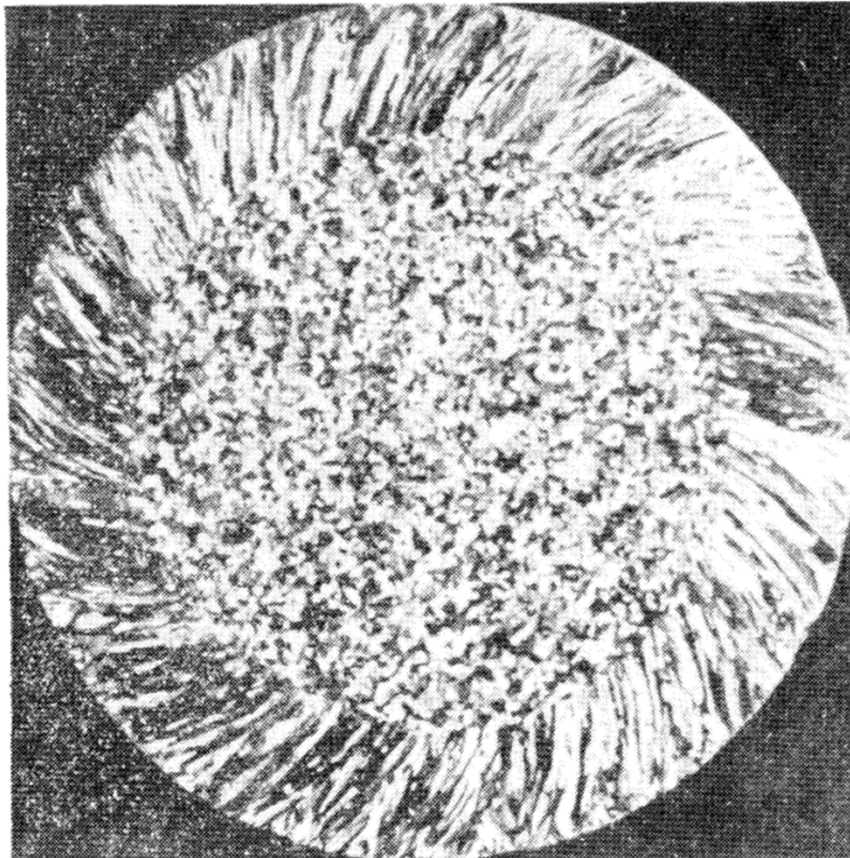


Fig. 8.18. Effect of rotation of the liquid on grain size and columnar length.

b) Tilted to the top of the interface

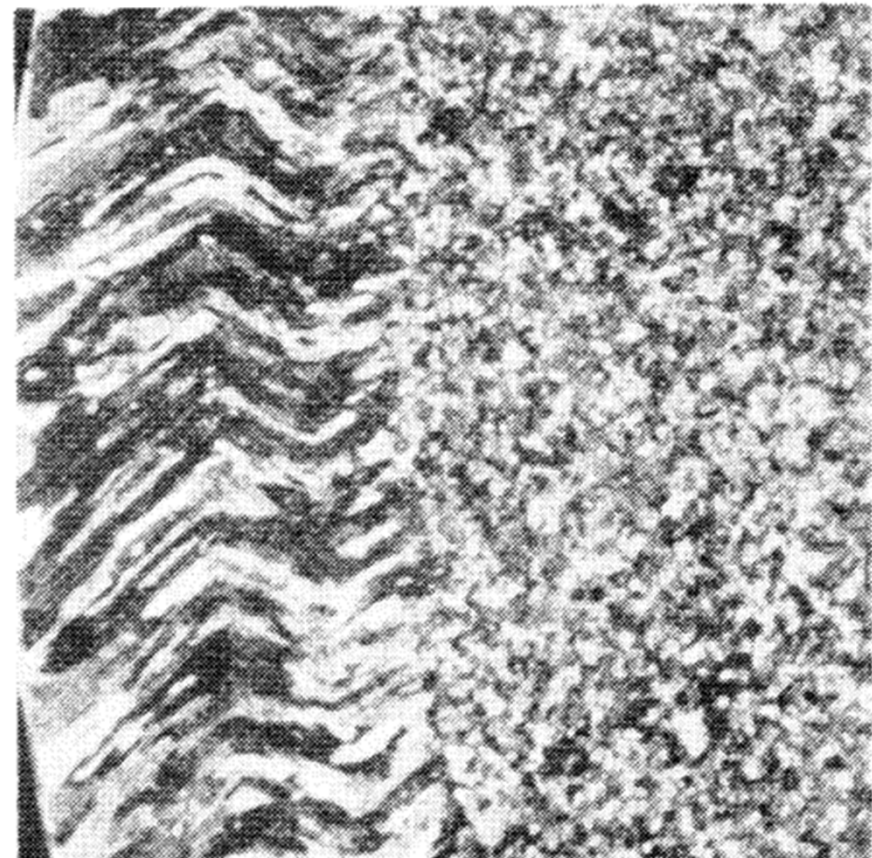


Fig. 8.19. Effect of rotation on the columnar structure. (effect of rotation reversing)

(5) Thermal measurement: superheat ~ very soon disappear

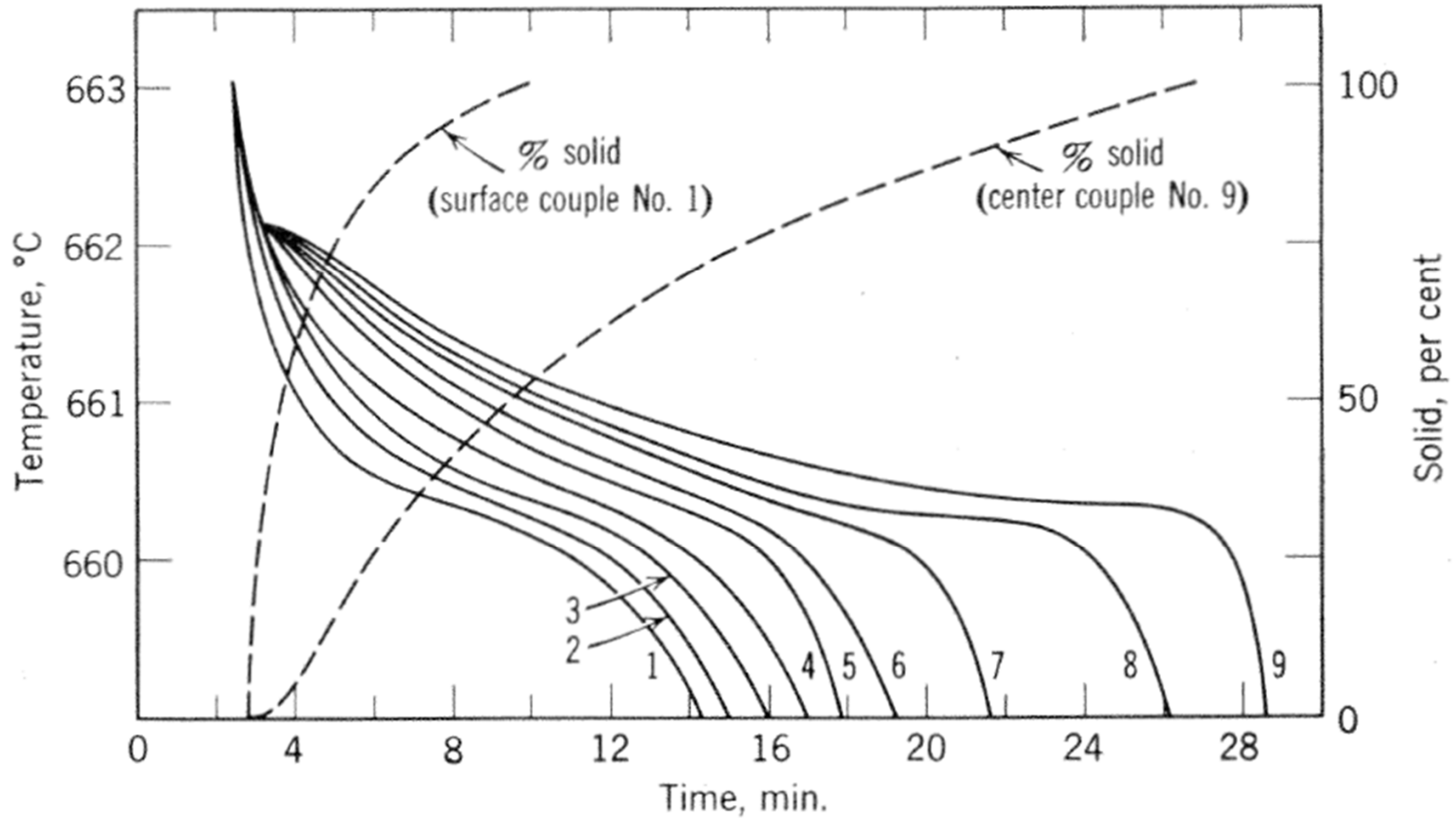


Fig. 8.23. Cooling curves for an ingot of super purity aluminum with 0.11% titanium.

## (6) Grain refiners

: empirical findings

**Ex.** Table I – Chemical analysis of A356 base alloy used in the pre-screening grain refining tests (wt%).

Al	Si	Mg	Fe	Zn	Ti	Others
Bal.	7.25	0.33	0.06	0.02	<0.01	<0.01

Table II – Chemical analysis of candidates used in laboratory grain refining tests and the addition rates tested.

Grain refiner	Composition (wt%)	Addition rate (kg/tonne)
TiBAlloy™	1.6% Ti-1.4% B	2.0
Hydloy™	1.2% Ti-0.5% B	5.6
Strobloy™	5% Sr-1.5% Ti-1.3% B	2.15
15Sr3Ti1B	15% Sr-3% Ti-1% B	2.8
Al-5% Ti-1% B	5% Ti-1.0% B	2.8
Al-3% Ti-1% B	3% Ti-1.0% B	2.8
Stoichiometric	2.3% Ti-1.0% B	2.8
Al-3% B	3% B	0.93
Al-8% B	8% B	0.35
Al-3% Ti-0.15% C	3% Ti-0.15% C	2.0
Al-Ti-C-B	2.9% Ti-0.10% C-0.04% B	2.0

Table III – Ranking of grain refiner performance in the pre-screening tests.

Poor refinement	Insufficient refinement	Good refinement (incubation period req'd)	Good refinement
Al-8% B	Al-3% B	Al-3% Ti-1% B	Remainder
Al-3% Ti-0.15% C	Al-Ti-C-B		(see Table II)

## (7) Structure of continuous casting

- \* To reduce segregation, grain size and porosity in casting or ingot  
→ Solidification rate  $\uparrow$  → But, in case of casting, possible to obtain by mold wall conductivity  $\uparrow$  or casting size  $\downarrow$  →  $\therefore$  “continuous casting”
- \* Key process parameters: Advance rate of isotherm + temp. gradient of liquid  
→ Determination of supercooling (temp. reduction measurement at given point)

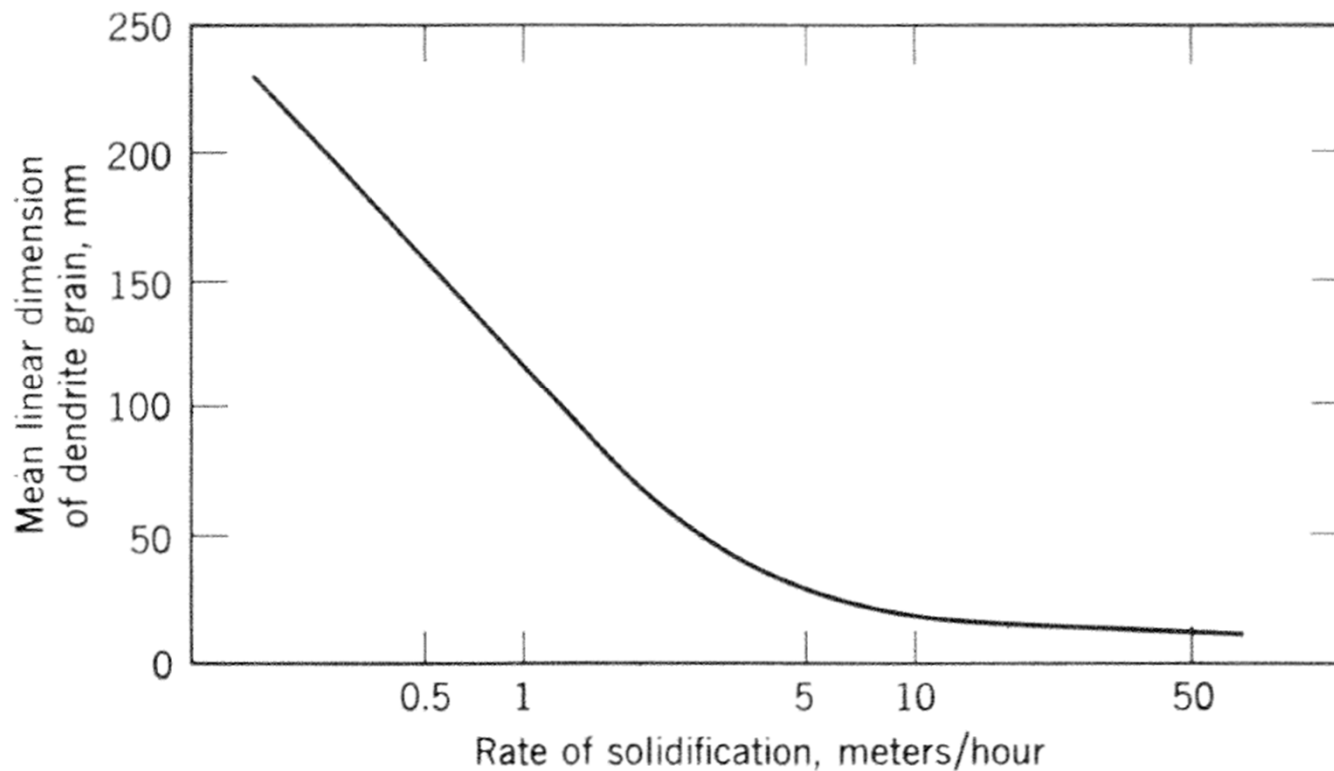


Fig. 8.24. Relation between rate of solidification and “dendritic grain size” for duralumin.



## (8) Effect of vibration on structure

\* Vibration: Effective when exposed during solidification rather than grain refinement / superheating

→ ① More nucleation ② Small crystal dispersion similar with turbulence formation.

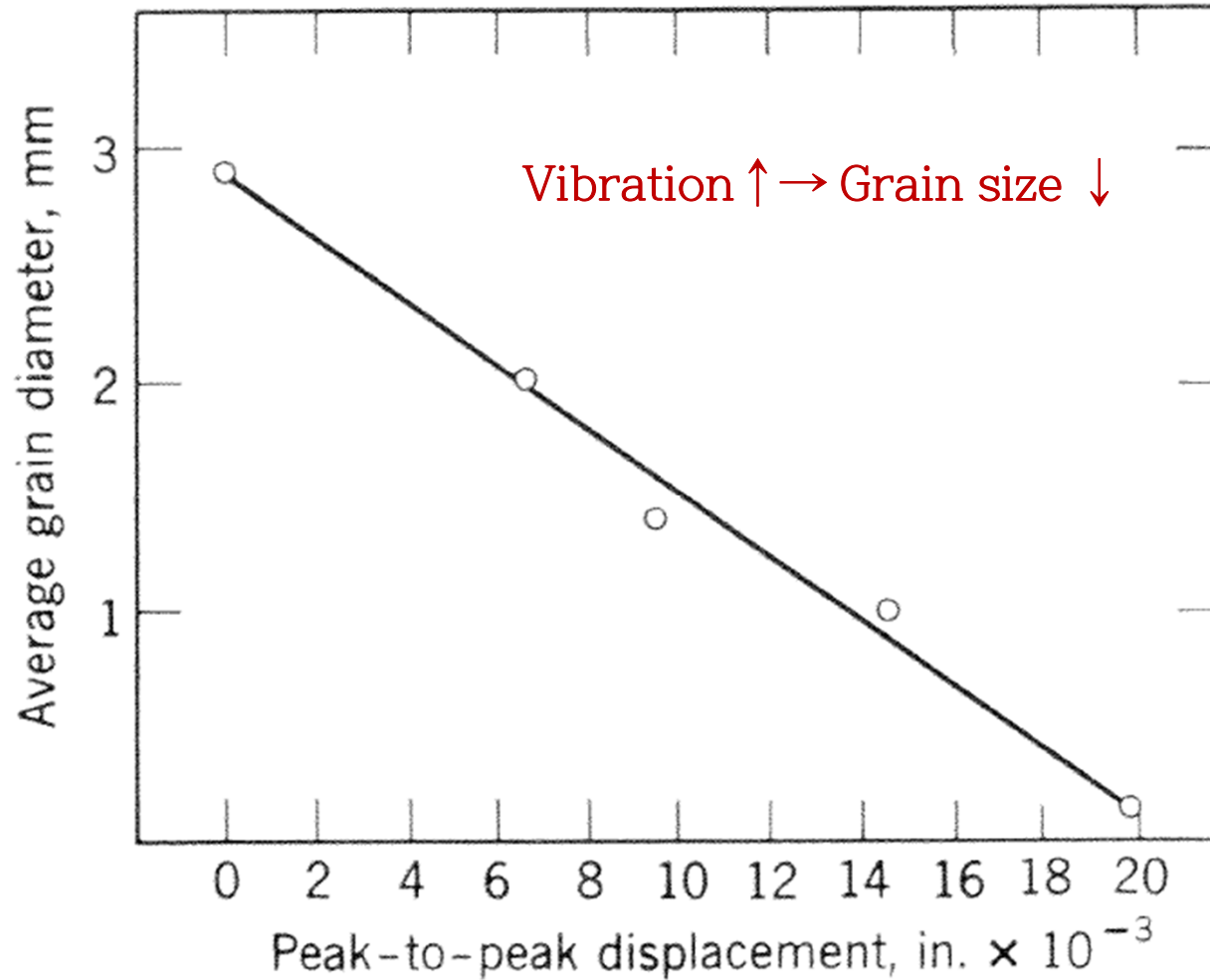


Fig. 8.25. Effect of amplitude of vibration on grain size.

## (8) Effect of vibration on structure

\* **Vibration:** Effective when exposed during solidification rather than grain refinement / superheating

→ ① **More nucleation** ② **Small crystal dispersion similar with turbulence formation.**

a) Effect of Vibration amplitude

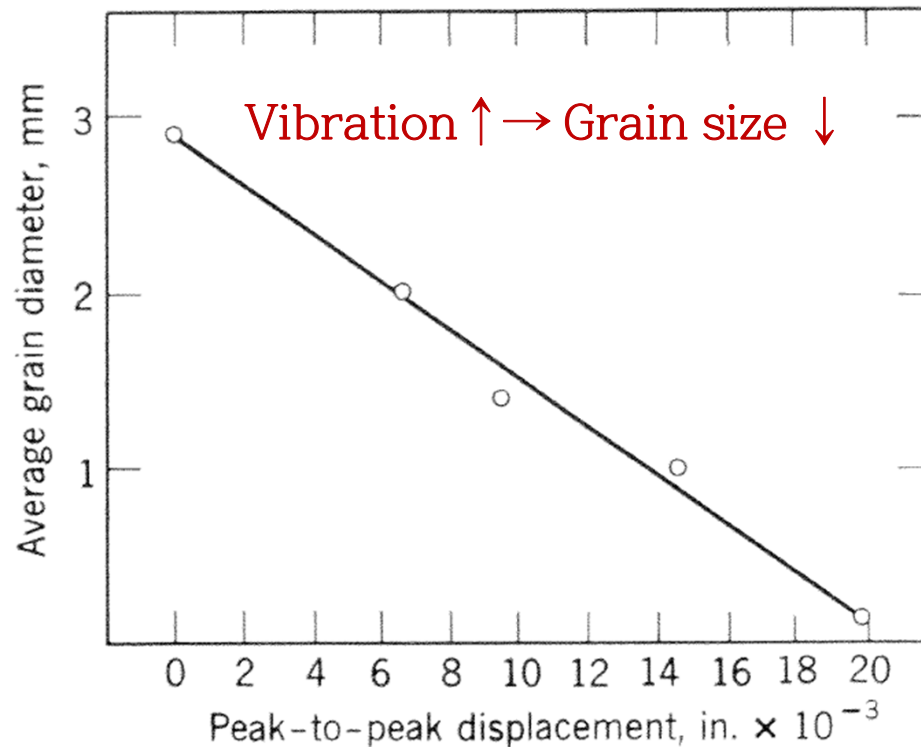


Fig. 8.25. Effect of amplitude of vibration on grain size.

b) Effect of pouring temp. in vibrated, unvibrated condition

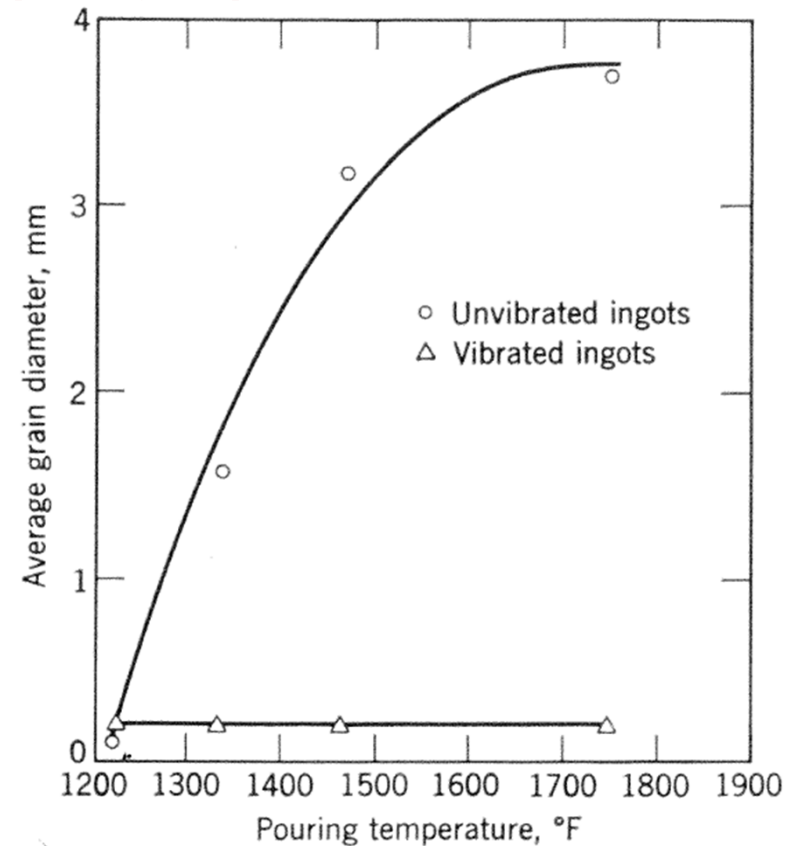


Fig. 8.26. Effect of pouring temperature on grain size.

## 8.3 Segregation

Solute rejection for solidification of alloy or impure metal → Redistribution by diffusion and mass flow → Effect of interface growth and propagation speed

Ex) Zone refining: possible to control of solute distribution

Other solidification: Interfacial shape complexity, difficult prediction of mass flow prediction → difficulty in quantitative prediction

### \* Factors affecting solute transport in liquids

① liquid motion

② Convection caused by density difference due to temperature difference

③ Convection due to density differences due to liquid composition changes as a result of solute rejection

④ Motion due to gravity of crystal growing in liquid

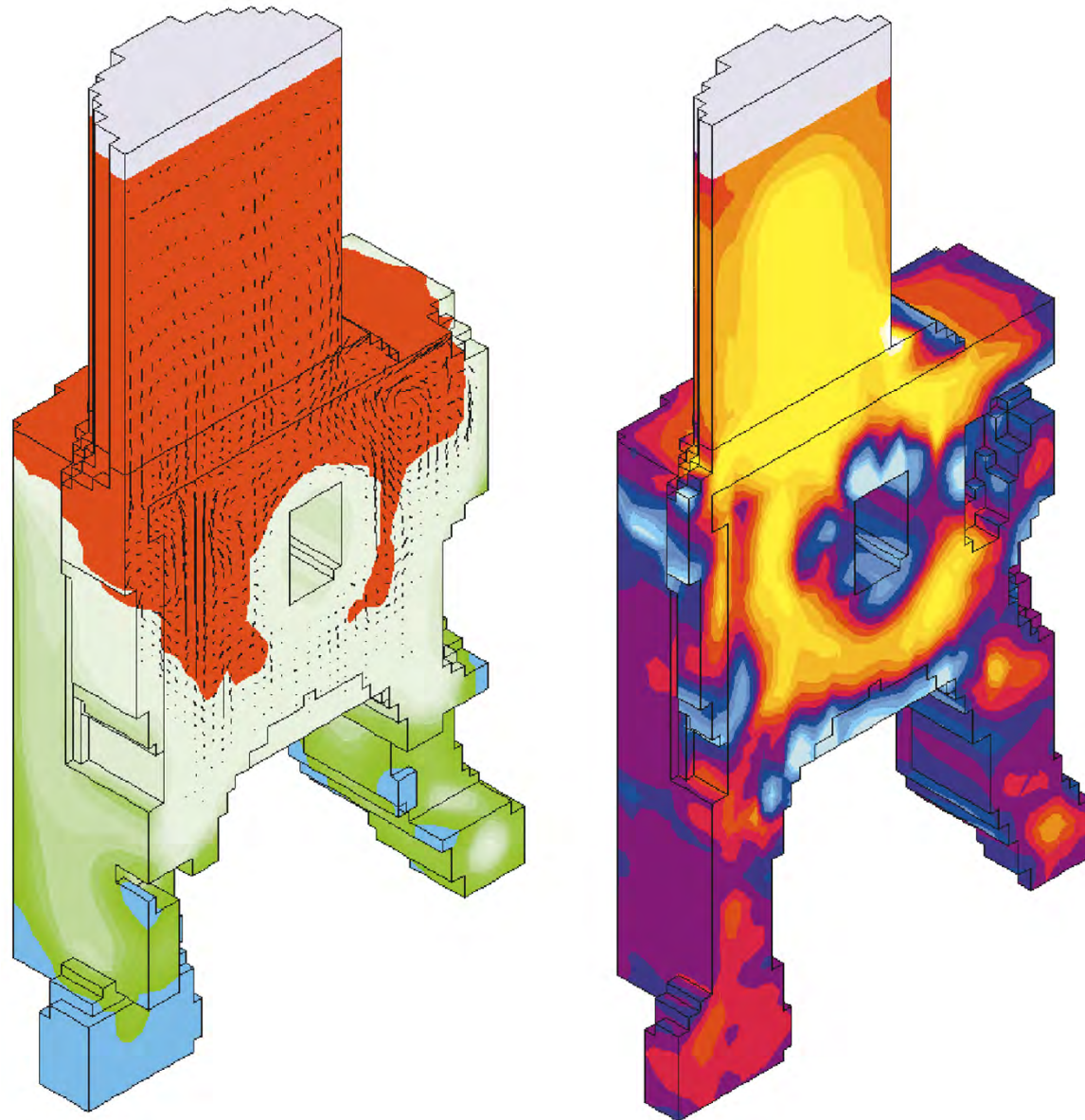
⑤ liquid motion due to solidification shrinkage

a) Micro segregation (short-range): inter-dendritic region (predictable)

b) Macro segregation (long-range): diffusion of en-riched liquid and mass movement

→ normal segregation (difficult to predict), inverse segregation (predictable) and gravity segregation (difficult to predict\_need to understanding of fluid motion)

**Fig.** Simulation of macrosegregation formation in a large steel casting, showing liquid velocity vectors during solidification (left) and final carbon macrosegregation pattern (right).



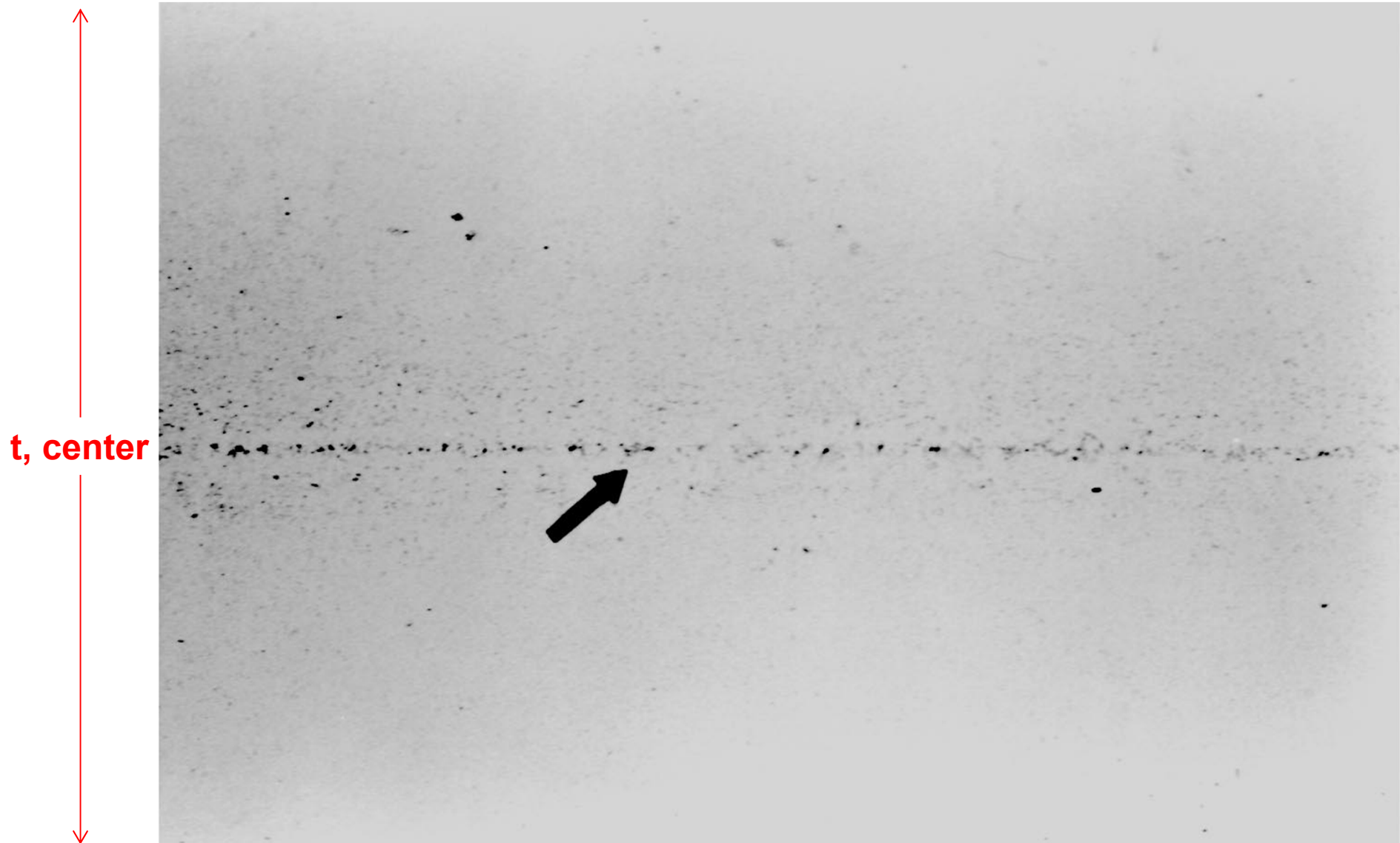
**Fig.**

**Freckles** in a single-crystal nickel-based superalloy prototype blade (left) and close-up of a single freckle (right) (courtesy of A. F. Giamei, United Technologies Research Center).

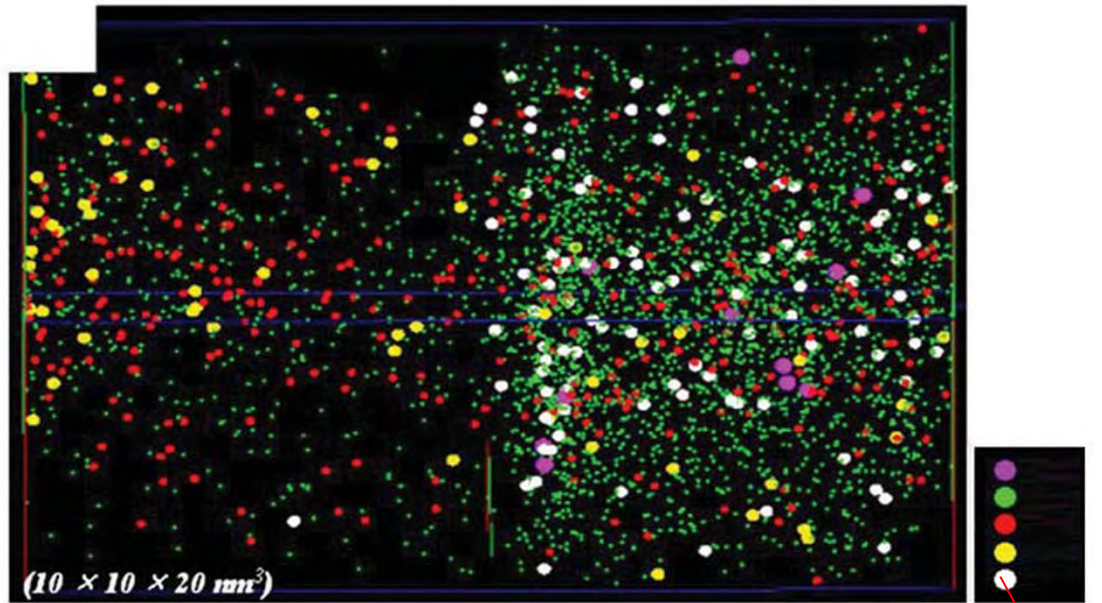
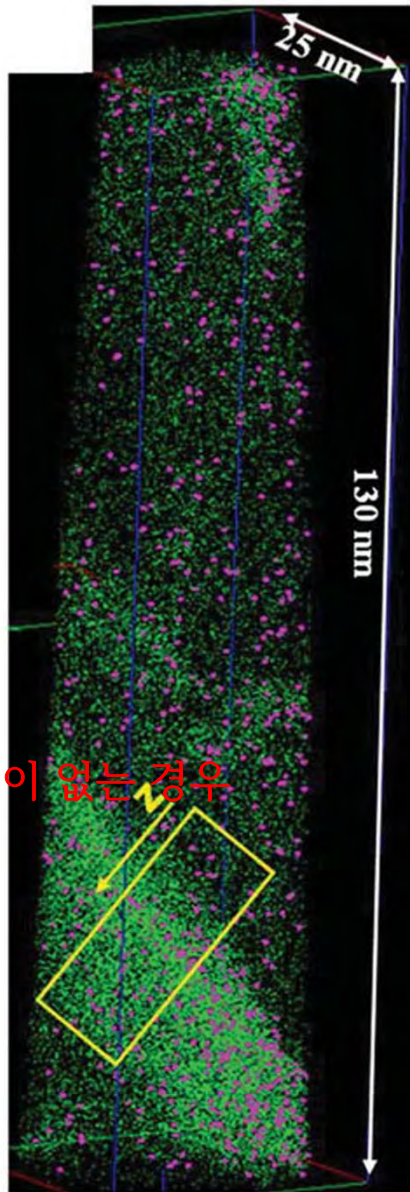


**Fig.**

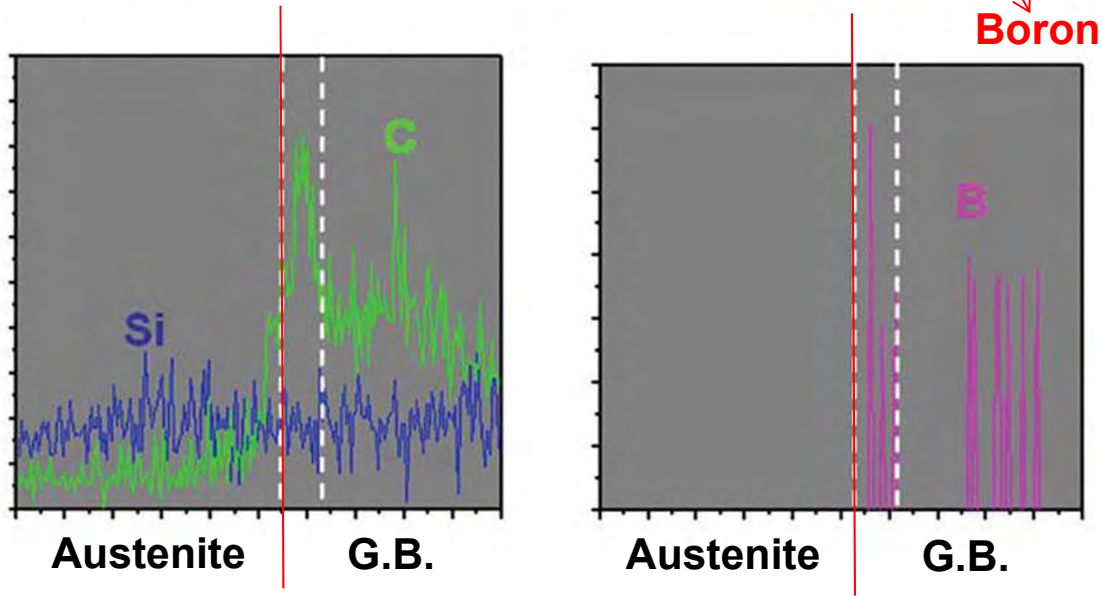
Sulfur print showing centerline segregation in a continuously cast steel slab (courtesy of IPSCO Inc.).



계면이 없는 경우



Boron



The result obtained by APT analysis. (a) 3D Atom map of **Boron steel containing 100 ppm Boron** and (b) composition profile showing **solute segregation within retained austenite and grain boundary**<sup>47</sup>

## 8.4. The significant of small-scale experiments

- Prediction of full scale structure and characteristics by small scale experiment  
But there are various variables to consider.

## 8.5. change of volume on Freezing

$T_m$ : liquid  $\rightarrow$  solid  $\Delta V$  positive (general)  $\rightarrow$  exsistance  $\rightarrow$  where? location

Table 8.1. Change of Volume on Solidification

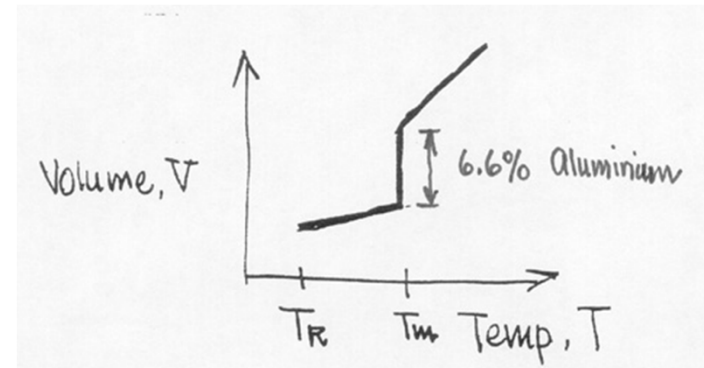
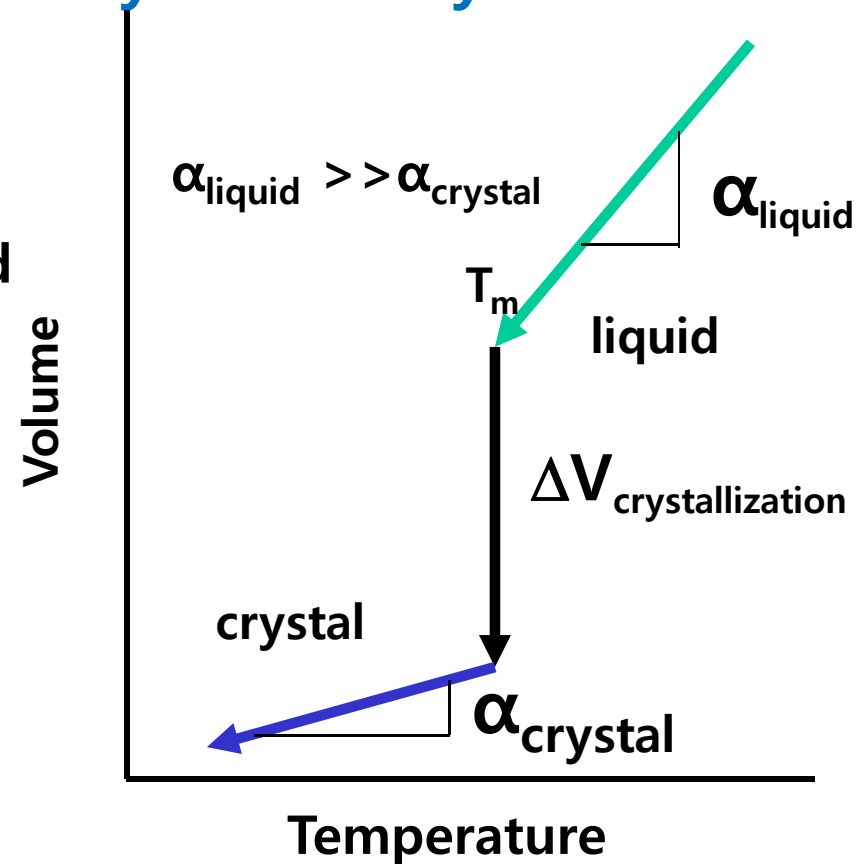
Element	$\Delta V$ (per cent)
Aluminum	-6.0
Magnesium	-5.1
Cadmium	-4.7
Zinc	-4.2
Copper	-4.1
Silver	-3.8
Mercury	-3.7
Lead	-3.5
Tin	-2.8
Sodium	-2.5
Potassium	-2.5
Iron	-2.2
Lithium	-1.65
Antimony	+0.95
Gallium	+3.2
Bismuth	+3.3



## \* Shrinkage

### Crystallization is Controlled by Thermodynamics

- Volume is high as a hot liquid
- Volume **shrinks** as liquid is cooled
- At the melting point,  $T_m$ , the liquid crystallizes to the thermodynamically stable crystalline phase
- More compact (generally) crystalline phase has a smaller volume
- The crystal then shrinks as it is further cooled to room temperature
- Slope of the cooling curve for liquid and solid is the **thermal expansion coefficient,  $\alpha$**



## Shrinkage effect

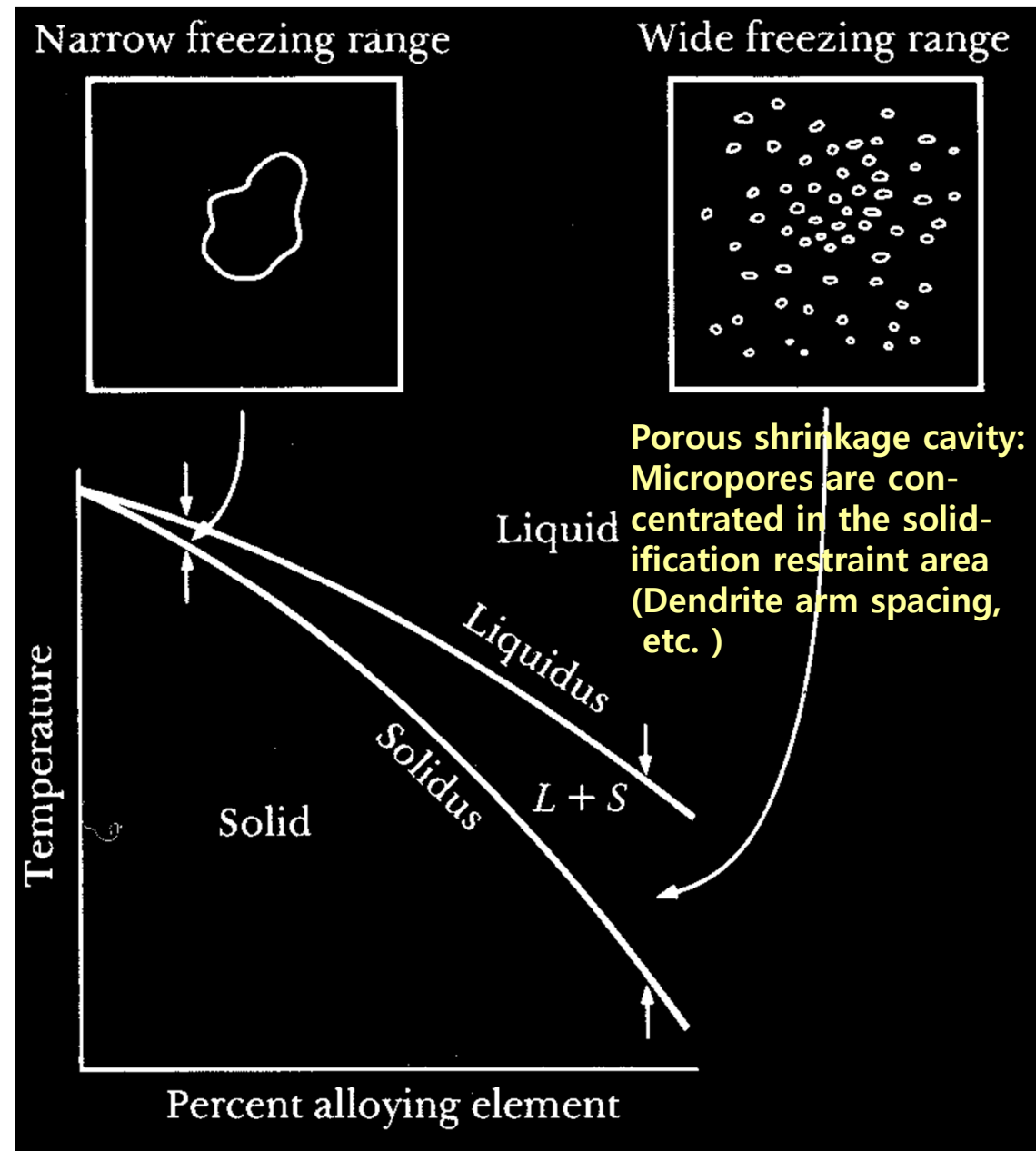
### \* Formation of Voids during solidification

**Center shrinkage cavity:** occurs at the casting center caused by  $\Delta V$  (solidification shrinkage at the time of solidification of castings with little change in composition)

**Dispersed micropores:**  
A very wide range of scattered micropores

Except for external shrinkage (around the mold) and primary shrinkage hole (surface), these shrinkage voids are mainly bubble defects

In the bubbles, there are CO, nitrogen, oxygen, and hydrogen in the iron alloy, hydrogen, oxygen in the copper alloy, and hydrogen in the aluminum alloy.



# Shrinkage in Solidification and Cooling

- Can amount to 5-10% by volume
- Gray cast iron expands upon solidification due to phase changes
- Need to design part and mold to take this amount into consideration

TABLE 5.1

<b>Metal or alloy</b>	<b>Volumetric solidification contraction (%)</b>	<b>Metal or alloy</b>	<b>Volumetric solidification contraction (%)</b>
Aluminum	6.6	70%Cu–30%Zn	4.5
Al–4.5%Cu	6.3	90%Cu–10%Al	4
Al–12%Si	3.8	Gray iron	Expansion to 2.5
Carbon steel	2.5–3	Magnesium	4.2
1% carbon steel	4	White iron	4–5.5
Copper	4.9	Zinc	6.5

Source: After R. A. Flinn.

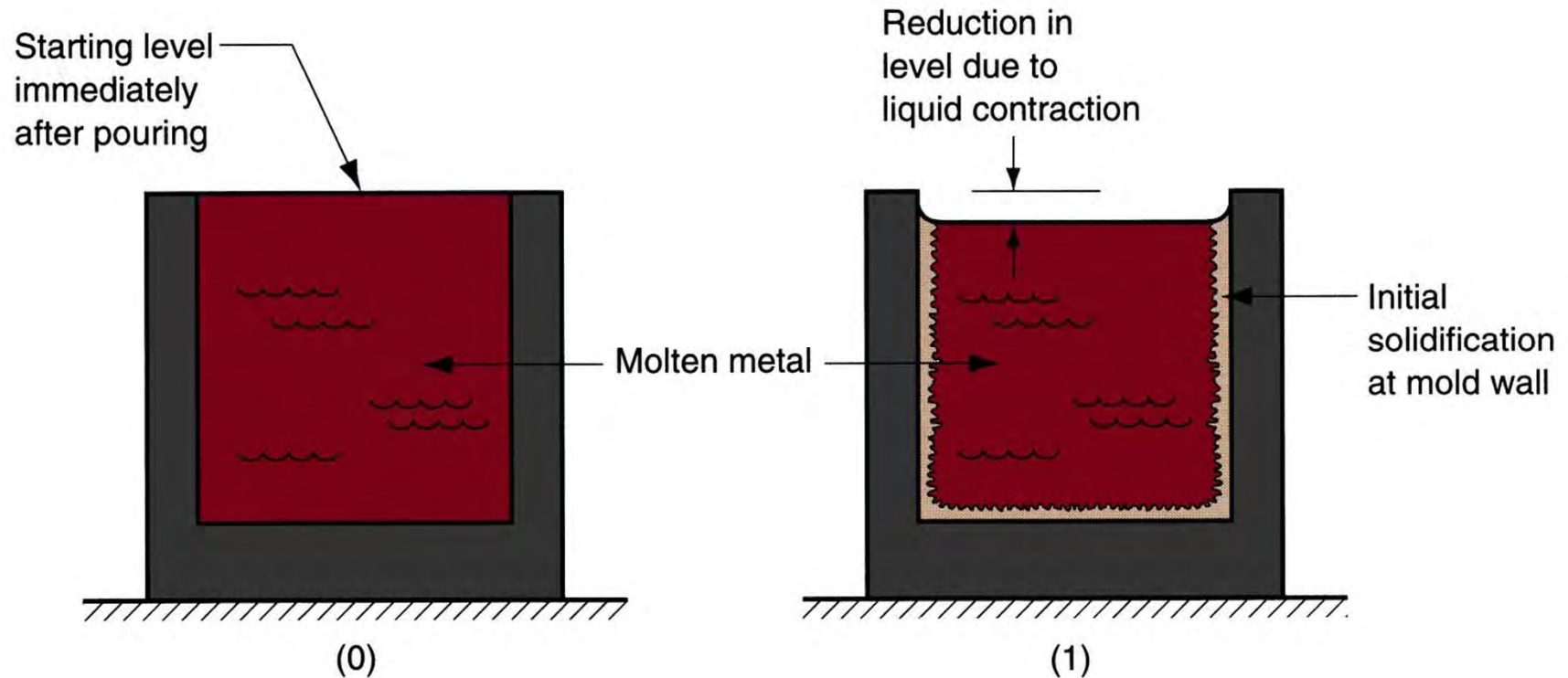
**\* Volumetric solidification expansion: H<sub>2</sub>O (10%), Si (20%), Ge**

ex) Al-Si eutectic alloy (casting alloy) → volumetric solidification contraction of Al substitutes volumetric solidification expansion of Si.

**Cast Iron: Fe + Carbon (~ 4%) + Si (~2%)**

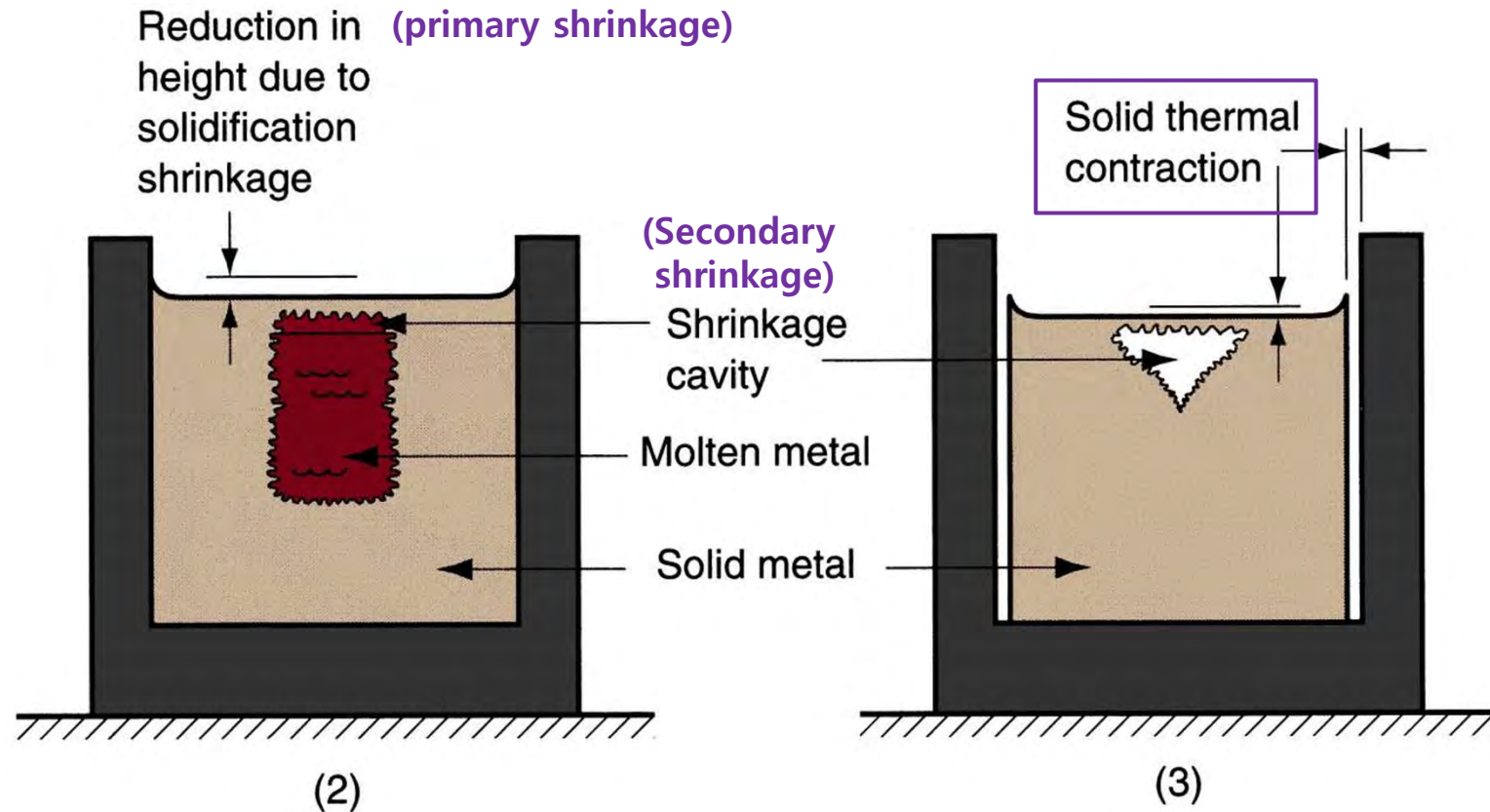
→ precipitation of graphite during solidification reduces shrinkage.

# Shrinkage in Solidification and Cooling



- \* Shrinkage of a cylindrical casting during solidification and cooling: (0) starting level of molten metal immediately after pouring; (1) reduction in level caused by liquid contraction during cooling (dimensional reductions are exaggerated for clarity).

# Shrinkage in Solidification and Cooling



- \* (2) reduction in height and formation of shrinkage cavity caused by solidification shrinkage; (3) further reduction in height and diameter due to thermal contraction during cooling of solid metal (dimensional reductions are exaggerated for clarity).

Fig. 8.27 Five types of Shrinkage

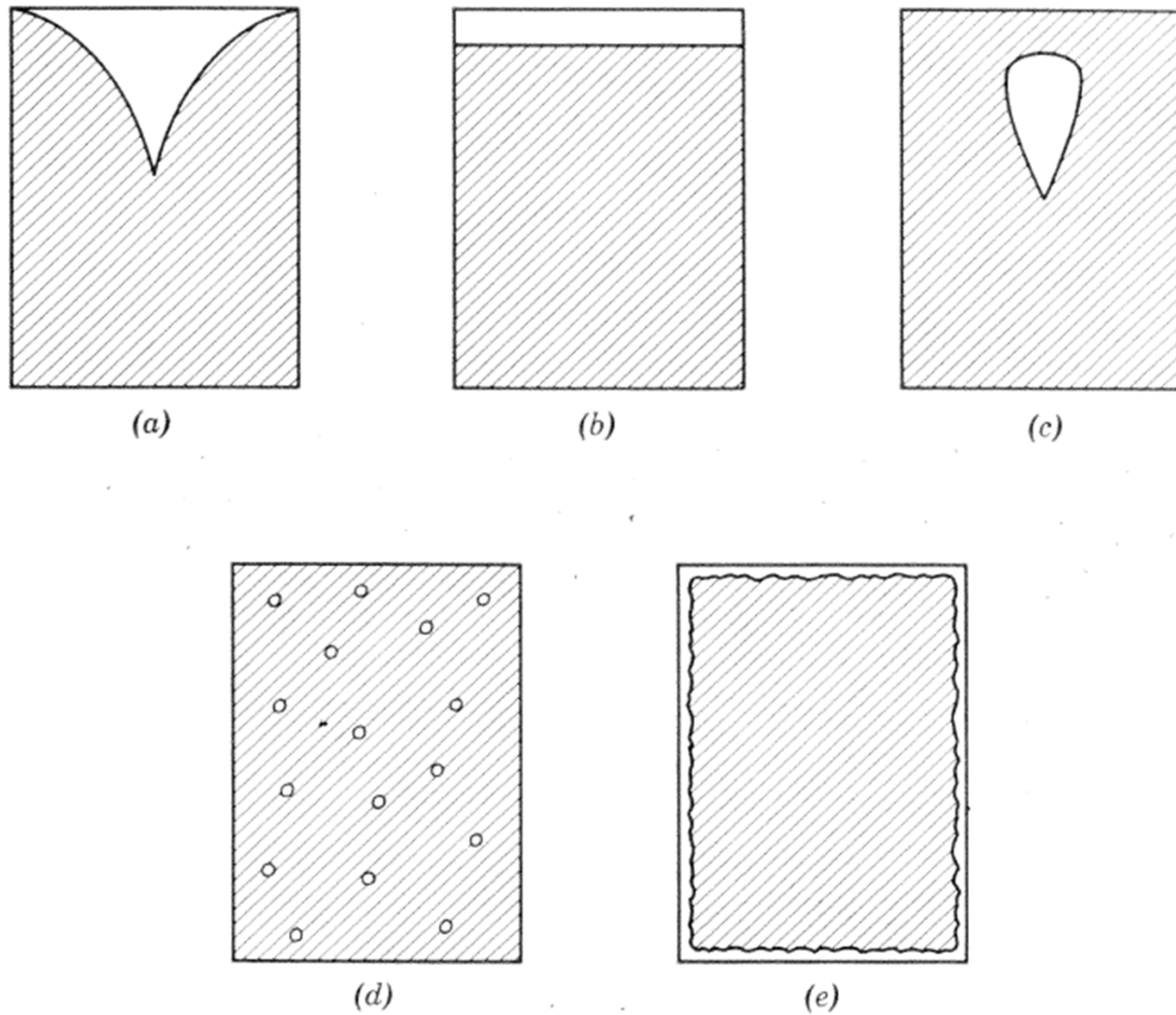


Fig. 8.27. Shrinkage effects. (a) Pipe, (b) unidirectional shrinkage, (c) cavity, (d) distributed porosity, (e) surface porosity.

① Pipe formation

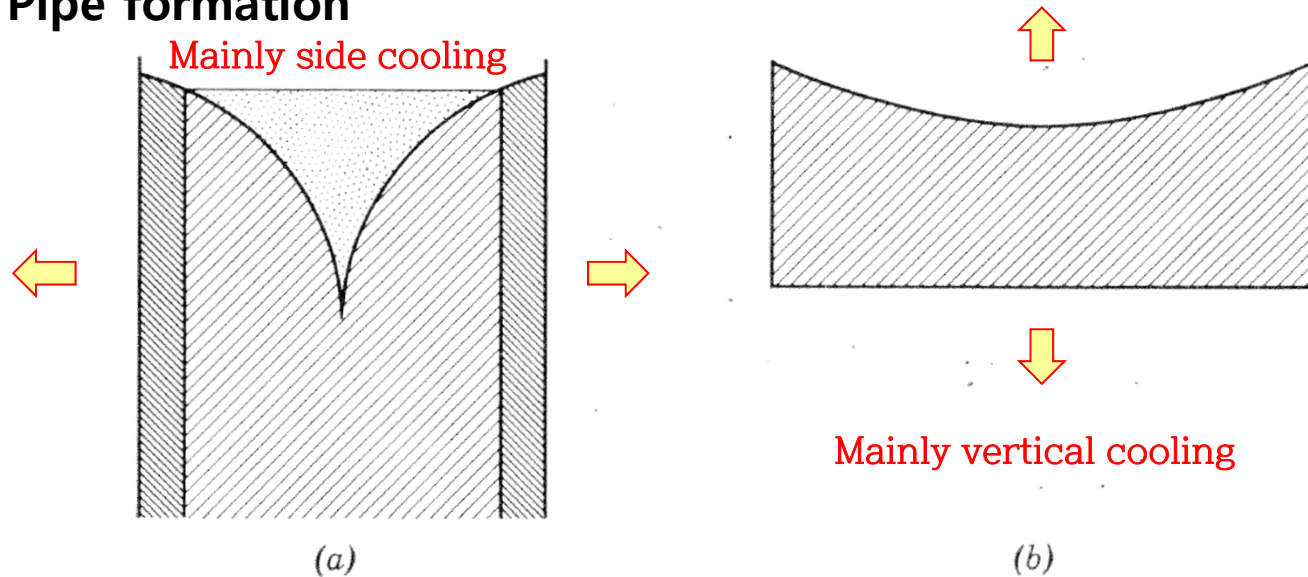
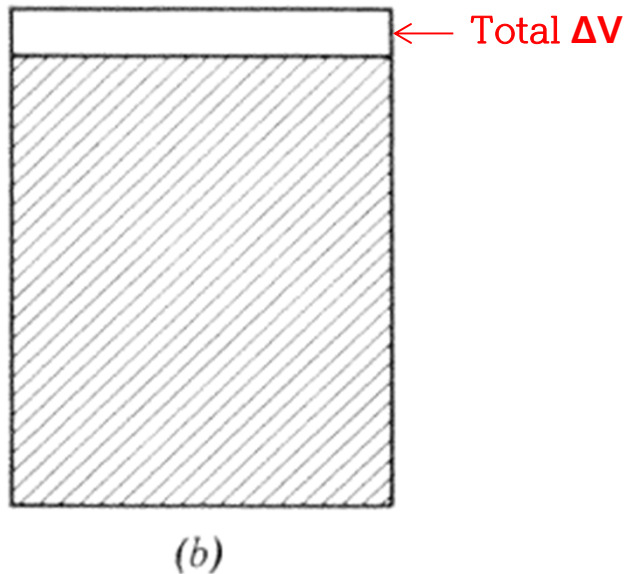
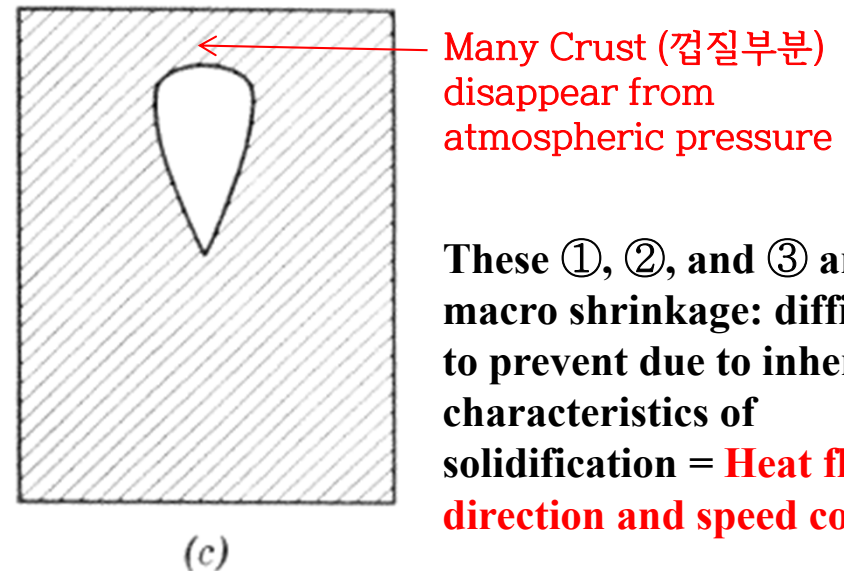


Fig. 8.28. Geometry of pipe. (a) Mainly lateral cooling, (b) mainly vertical cooling.

② Unidirectional Shrinkage



③ Cavity formation: in many practical cases



\* These ①, ②, and ③ are macro-shrinkage: difficult to prevent due to inherent characteristics of solidification. However, the presence of a pipe or cavity causes degradation of the material properties → The shrinkage position depends on the relative heat release of the mold in different regions.

\* Three ways of heat flow direction and speed control

a) Chill application: allows high conductivity for low conductivity mold

b) Padding: interferes with heat extraction by using low thermal conductivity material or by local preheating

c) Exothermic compounds: retarding the cooling of adjacent metals by supplying heat through mold material or casting

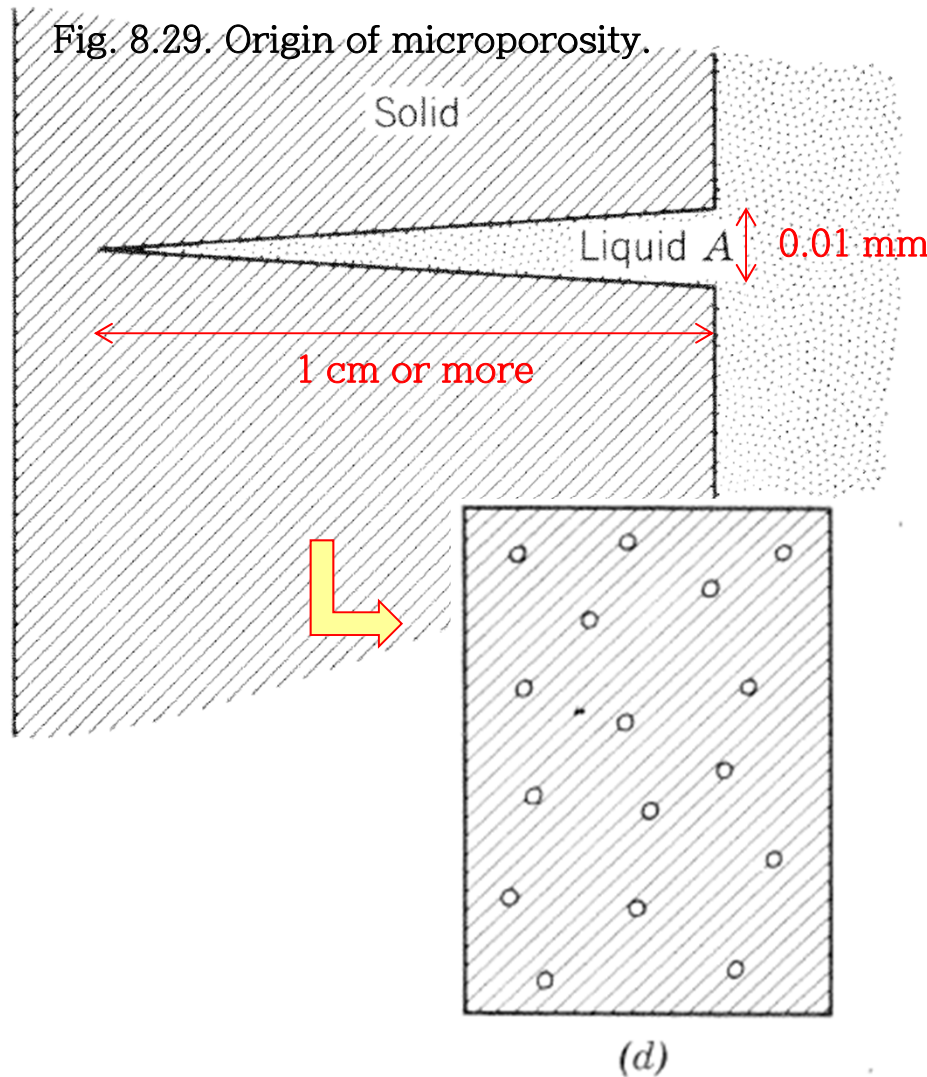
→ These methods are ancillary and the most important factor controlling cooling is the cross section related to the casting geometry, the ratio between the thermal capacity and the heat release area

→ The most desirable shape to induce the heat flow of the part containing the rejected solute is to ensure that it is not isolated from the last part by any liquid provided by the raisers.



#### ④ Porosity

Fig. 8.29. Origin of microporosity.

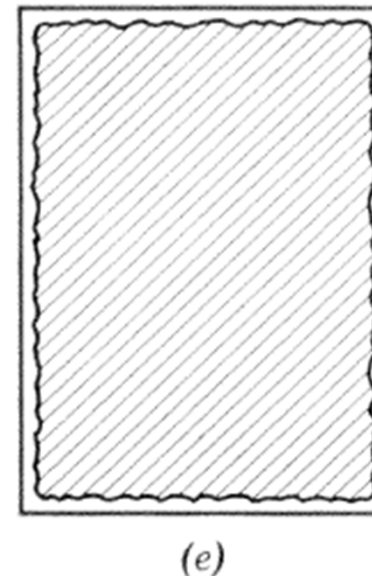


: Dendrite or Cellular-dendrite solidification = Liquid A with high viscosity is difficult to suck into the groove sufficiently

→ Pore occurrence in groove of wall

→ micropores

#### ⑤ surface porosity



### 8.6. Blow holes (page 191)

= cylindrical cavities

→ exist a hydrogen upper limit for sound ingot production

Carbon steel

6.5 cm<sup>3</sup>/100 gm

Low alloy steel

7 cm<sup>3</sup>/100 gm

Chromium (ferritic) stainless

10 cm<sup>3</sup>/100 gm

Austenitic stainless

12 cm<sup>3</sup>/100 gm

## 8.7. Surface Topography Resulting from Solidification

- Prediction of successful solidification → From surface observation
  - : In most cases, the as-cast surface departs from the topography of the mold by amounts that would be measured in millimeters.
- ① **Surface tension effects:** Difficult to fill completely due to liquid pressure at sharp edge or corner of mold.
- ② **Cold shut**
- ③ **Trapped gas**
- ④ **Surface dendrite**
- ⑤ **Extrudation (→ inverse segregation) and surface porosity**
- ⑥ **Topography of the free surface → decided by surface tension & shrinkage**
- ⑦ **metal coating by hot dipping**

## 8.7. Surface Topography Resulting from Solidification

\* Prediction of successful solidification → From surface observation

: In most cases, the as-cast surface departs from the topography of the mold by amounts that would be measured in millimeters.

① **Surface tension effects:** The surface tension of the liquid results in the pressure difference btw liquid (R1) and adjacent medium (R2)

→ As a result, it is difficult to completely fill the sharp edge or corner of the mold due to the liquid pressure.

Ex) In the case of metal ~ generally  
surface tension ~ 500 dynes/cm

→ A radius of 1/100 mm ( $10^{-3}$  cm) adds additional pressure to the liquid up to 1 atm.

$$P = \sigma \left( \frac{1}{R_1} + \frac{1}{R_2} \right)$$

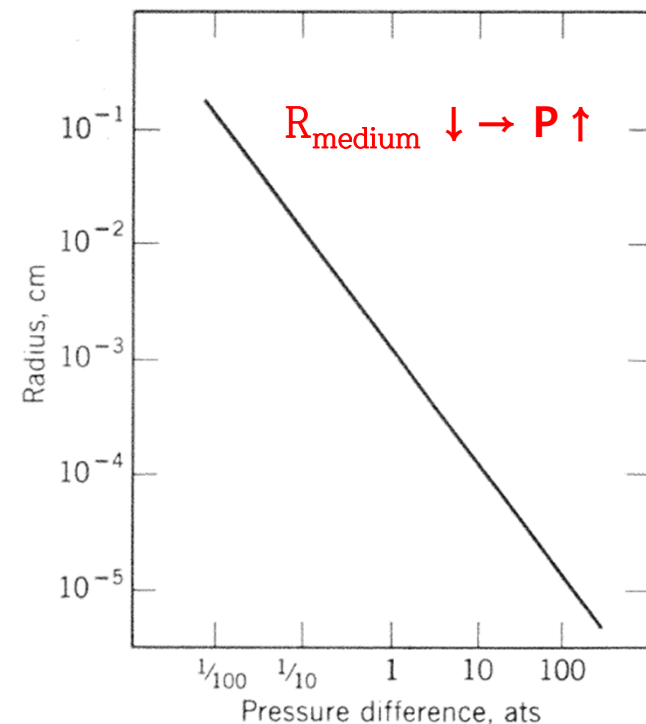


Fig. 8.30. Limiting radius of curvature of surface of a liquid as a function of pressure difference.

② **Cold shut:** Some liquids solidify in a discontinuous state that is not in contact with previously solidified liquid.

a) Occurs in the presence of an oxide film on a solid substrate or liquid surface.

b) Occurs due to metal splashing when molten metal is poured.

→ Drops or splashes are pre-cooled in contact with mold above liquid level.

③ **Trapped gas:** Interference of contact between solid skin and mold

→ trapped gas at cleavage of mold wall/ Water vapor from mold or mold-dressing/ Separation of solid skin and mold by gas bubble from mold-metal reaction\_ Rapid decrease in thermal conductivity

④ **Surface dendrite:** dendritic growth at surface layer

→ Small crystal formed during rapid chilling

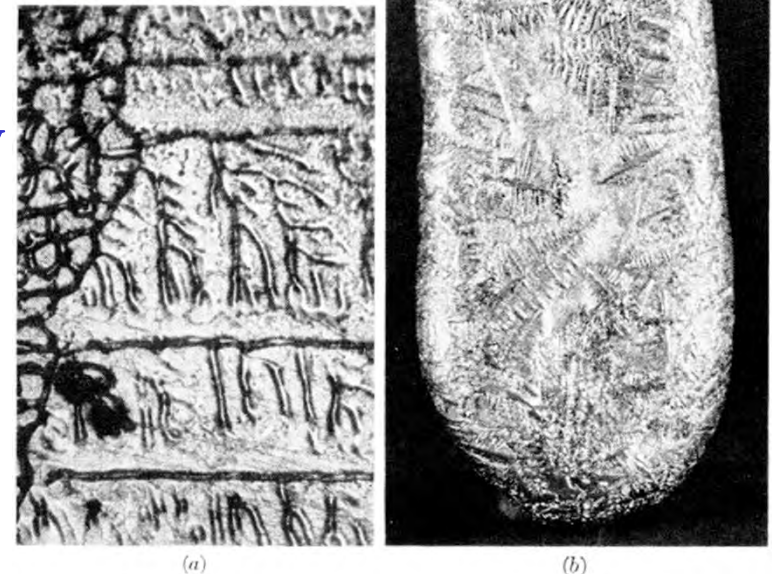
→ rapid growth in parallel to the surface

→ Failed to fill interdendritic space completely

\* **Formation of surface dendrite**

a) Large supercooling ↔ b) Remelting & slow cooling  
→ formation of large crystal      → Formation of fewer crystals but formation of dendrite by effect of supercooling

Fig. 8.31. Surface dendrites. (a) Supercooled, x100; (b) slowly cooled, x1.



## ⑤ Extrudation and surface porosity

a) **Extudation** (스며나옴) : Melt-back effect in the formation of the Dendrite skeleton can be occurred by extrusion toward the mold prior to complete solidification of the inter-dendritic liquid

: These drops come from the interdendritic region → much richer in solute  
→ **lead to inverse segregation**

b) **Surface porosity** : In the formation of Dendrite skeleton, the surface skin is rapidly solidified and then the solidification contraction occurs when the inner interdendritic area is solidified.

## ⑥ Topography of the free surface → Determined by surface tension and shrinkage

\* Surface change mechanism after solidification

a) chemical reaction → formation of oxide, etc.

b) thermal etching → surface terrace formation or groove formation in G.B.

c) vacancy pit formation: Reduction of equil. vacancy concentration when temperature decreases → If there is sufficient time, the excess vacancy diffuses to the surface to form pit. → Generally, the pit is small and has a pyramidal shape.

## ⑦ metal coating by hot dipping

: Coating by dipping on metal bath with low melting temperature

a) Tin-plated steel sheet (주석도금 강판)

Formation of “River structure”: Separation of roller and tin surfaces by surface cavitation causing instability during rolling

b) Hot dipped Zinc\_galvanized steel sheet (아연도금강판)

Formation of Spangle: Large undercooling occurs during cooling

→ relatively few crystal nuclei are formed

→ each crystal can be visually confirmed by surface etching effect

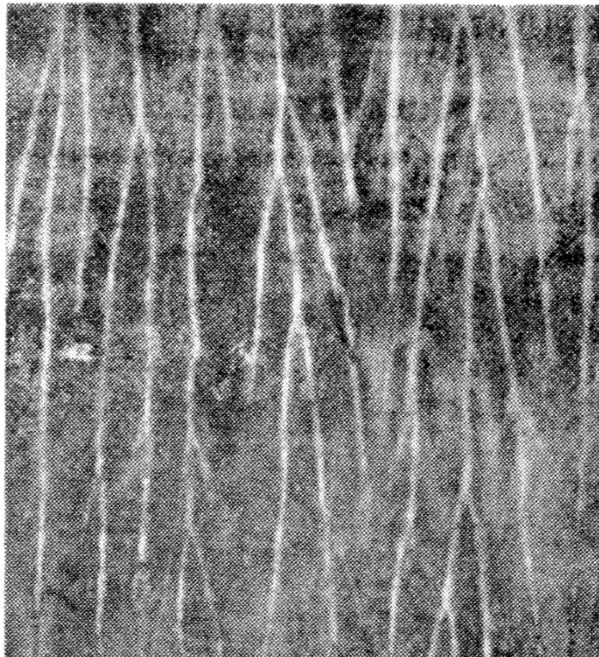
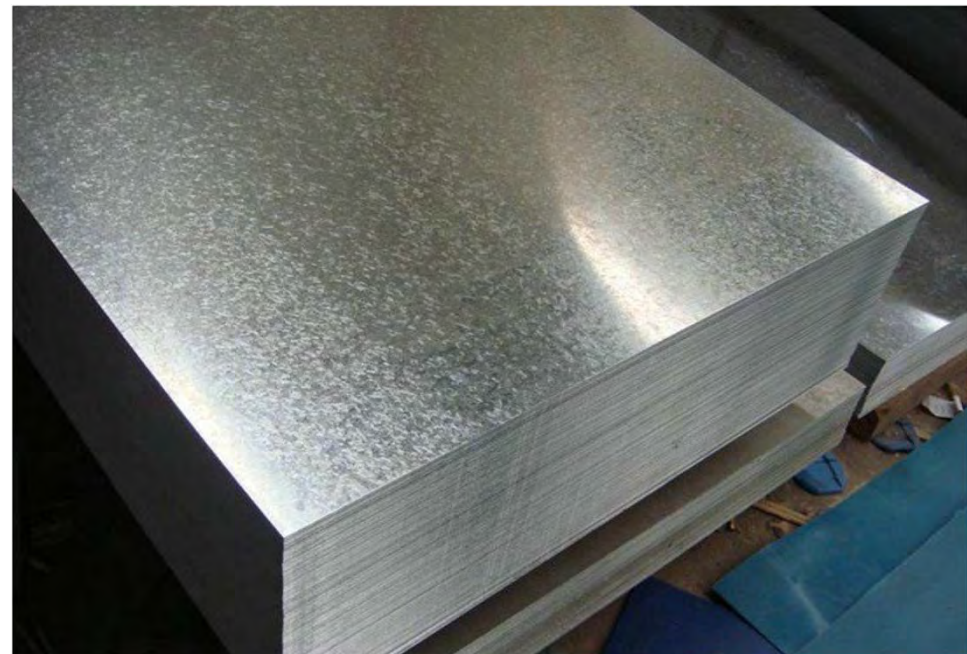


Fig. 8.32. River structure on tinplate.



< Spangle phenomenon >

# ***Principles of Solidification***

- week 1** Brief introduction : the relevant thermodynamic laws, properties, and relationships
- week 2** Solidification as an Atomic Process I
- week 3** Solidification as an Atomic Process II
- week 4** Nucleation I
- week 5** Nucleation II
- week 6** Microscopic Heat Flow Consideration I
- week 7** Microscopic Heat Flow Consideration II
- week 8** Reduction of Solute during solidification I
- week 9** Reduction of Solute during solidification II
- week 10** Polyphase Solidification I
- week 11** Polyphase Solidification II
- week 12** Macroscopic Heat Flow and Fluid Flow I
- week 13** Macroscopic Heat Flow and Fluid Flow II
- week 14** The Structure of Cast Metals I
- week 15** The Structure of Cast Metals II