

© 2005 Brooks/Cole - Thomson

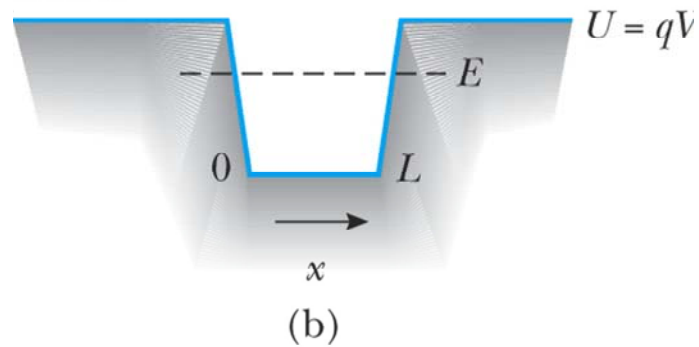

© 2005 Brooks/Cole - Thomson

Fig. 6-6, p. 201



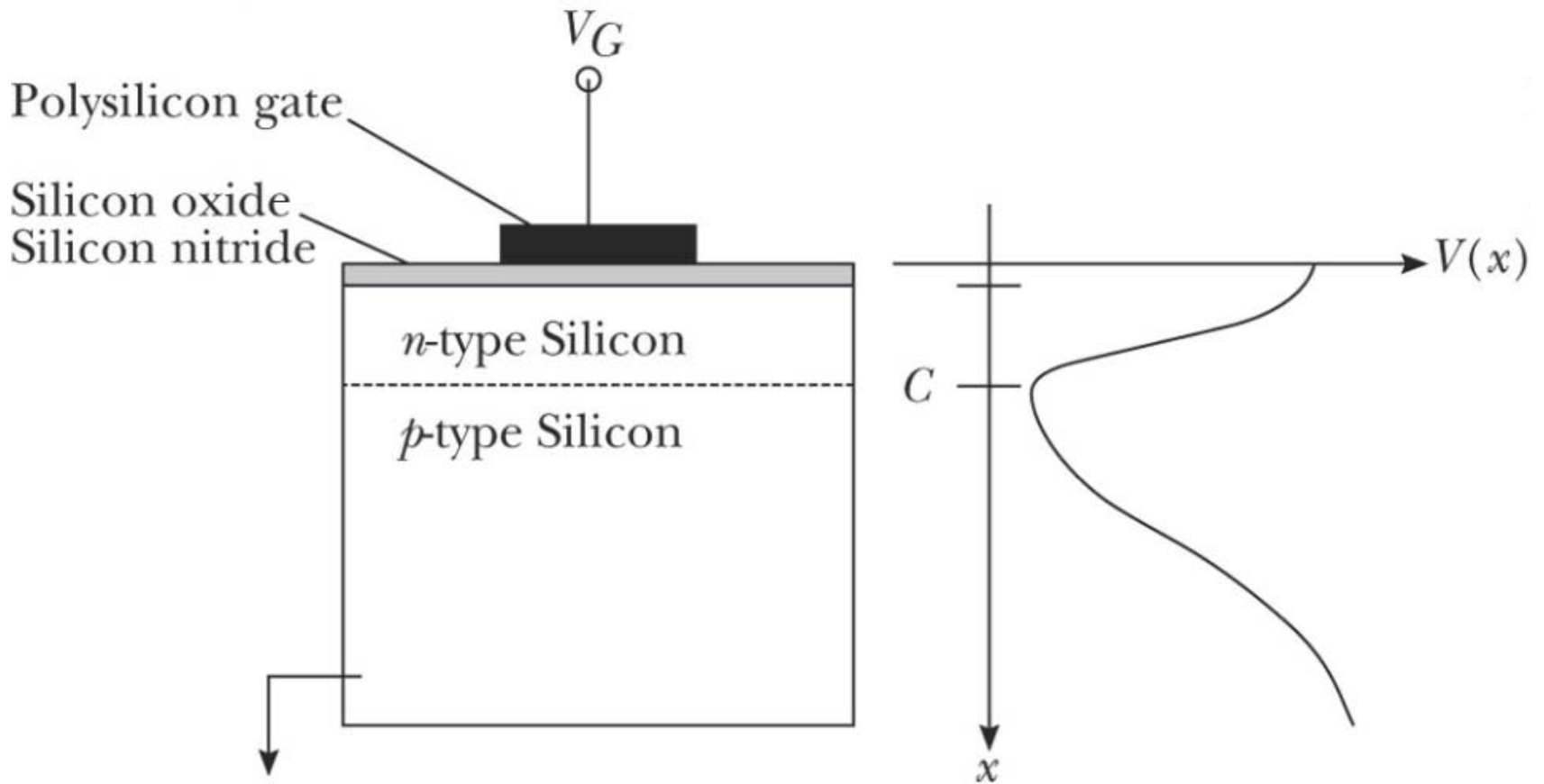

© 2005 Brooks/Cole - Thomson

Fig. 6-11, p. 206



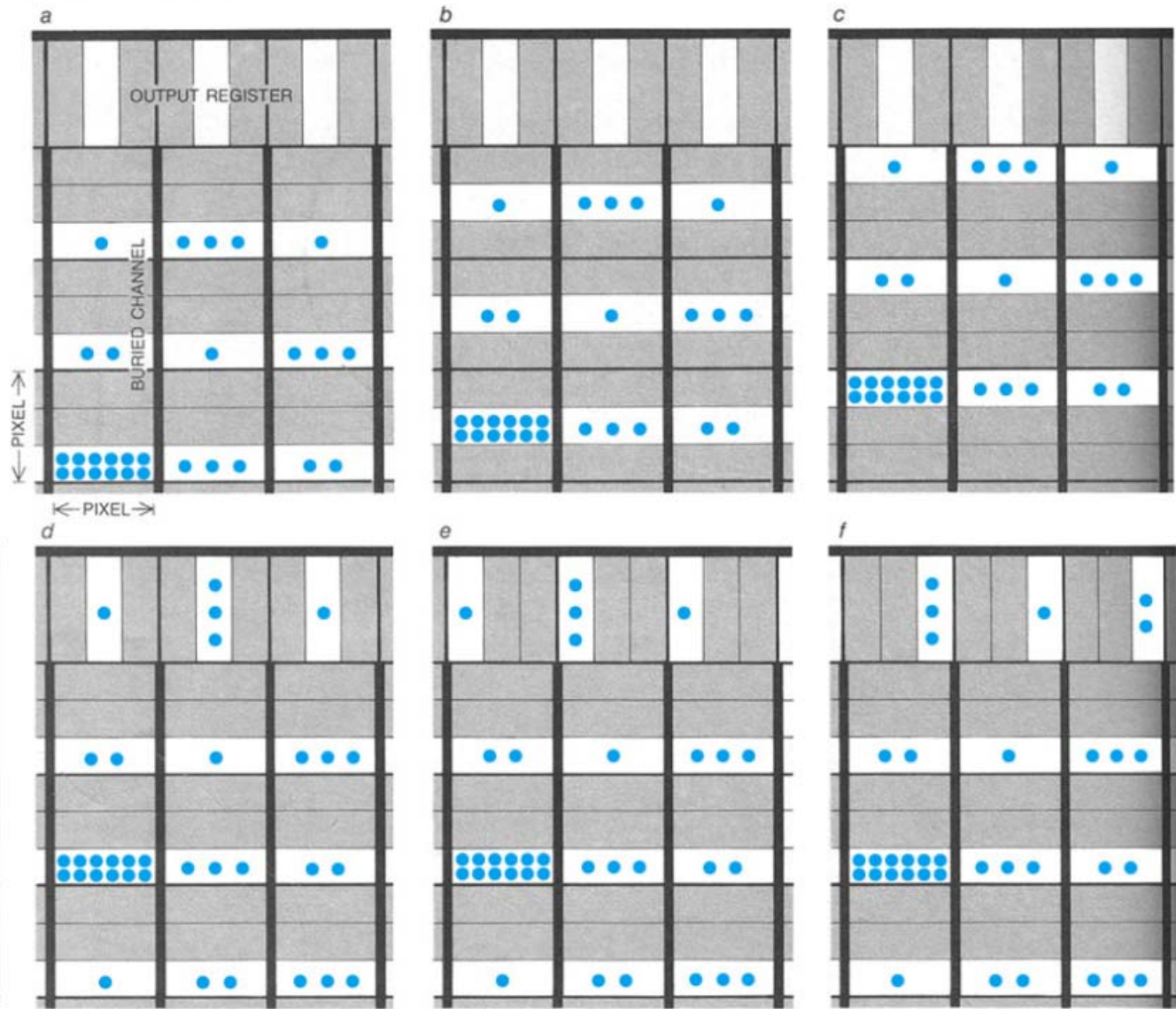

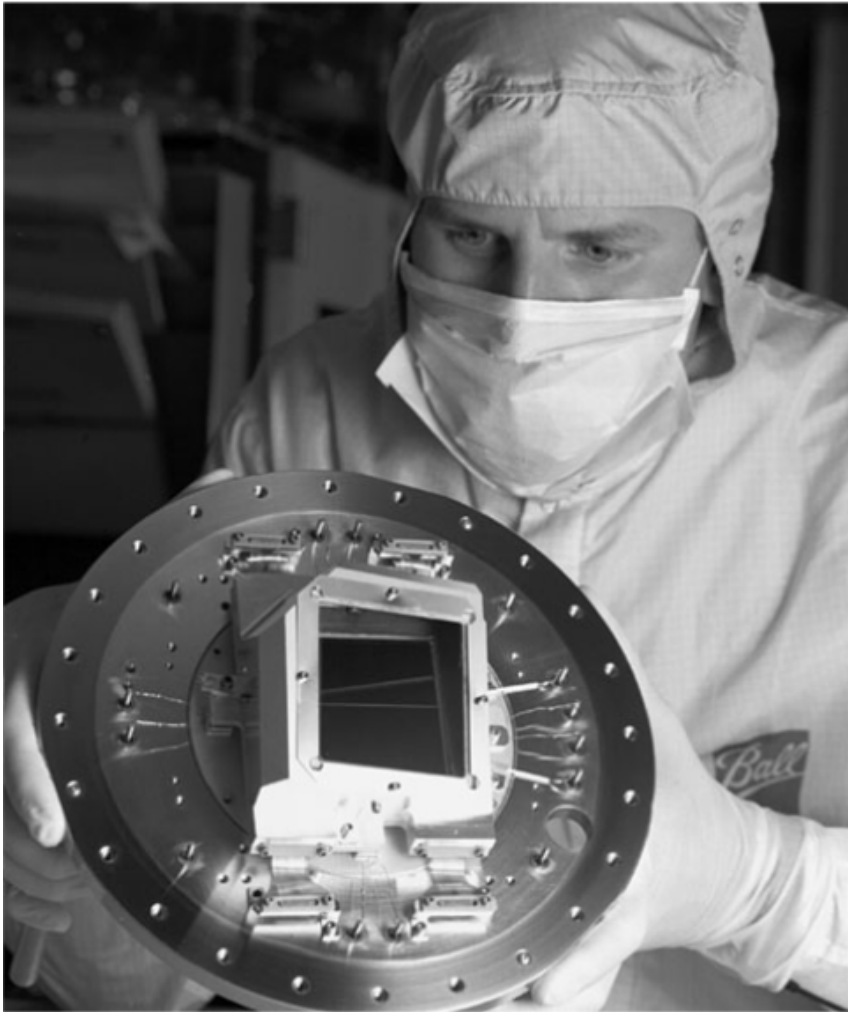

(a)

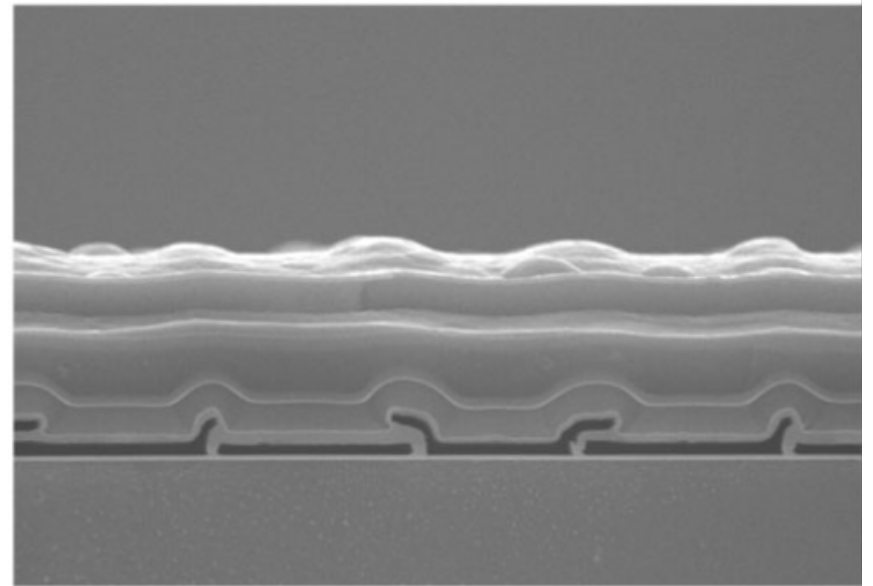

(b)

© 2005 Brooks/Cole - Thomson

Fig. 6-13, p. 208



Seoul National University

NRL HoloTech

Finite Potential Well

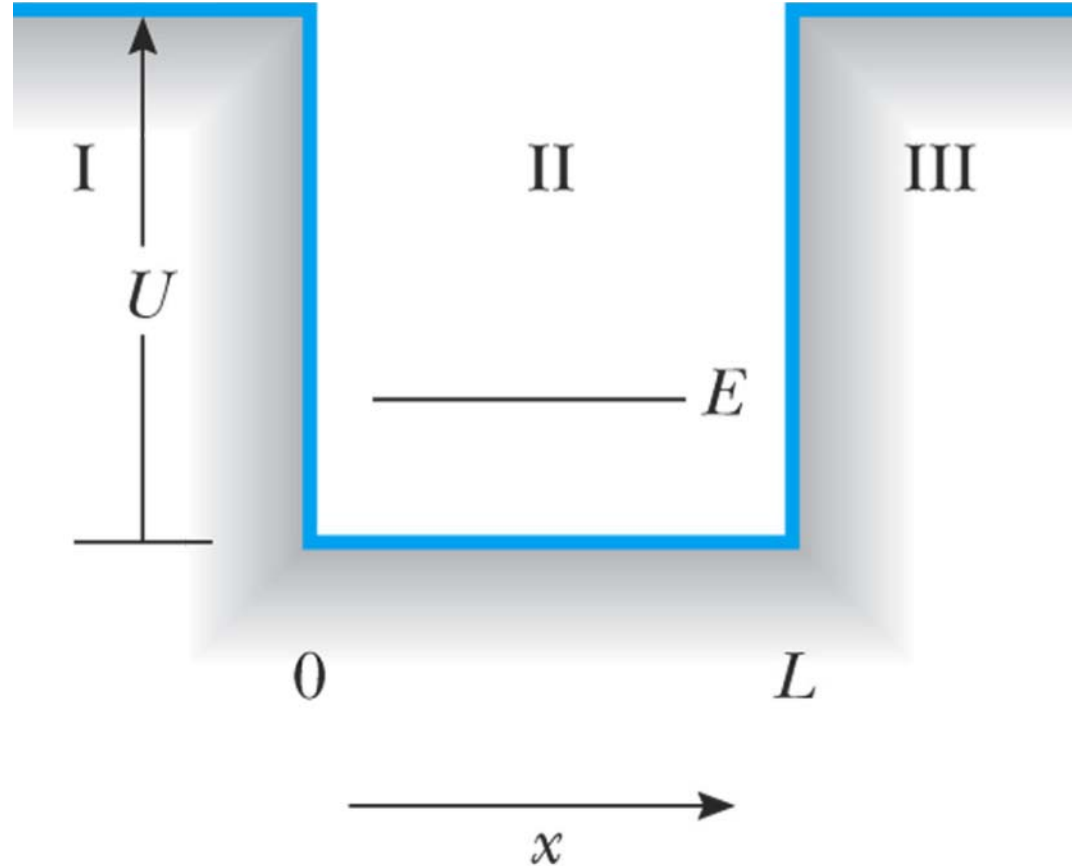

© 2005 Brooks/Cole - Thomson

Fig. 6-15, p. 209



Finite Potential Well

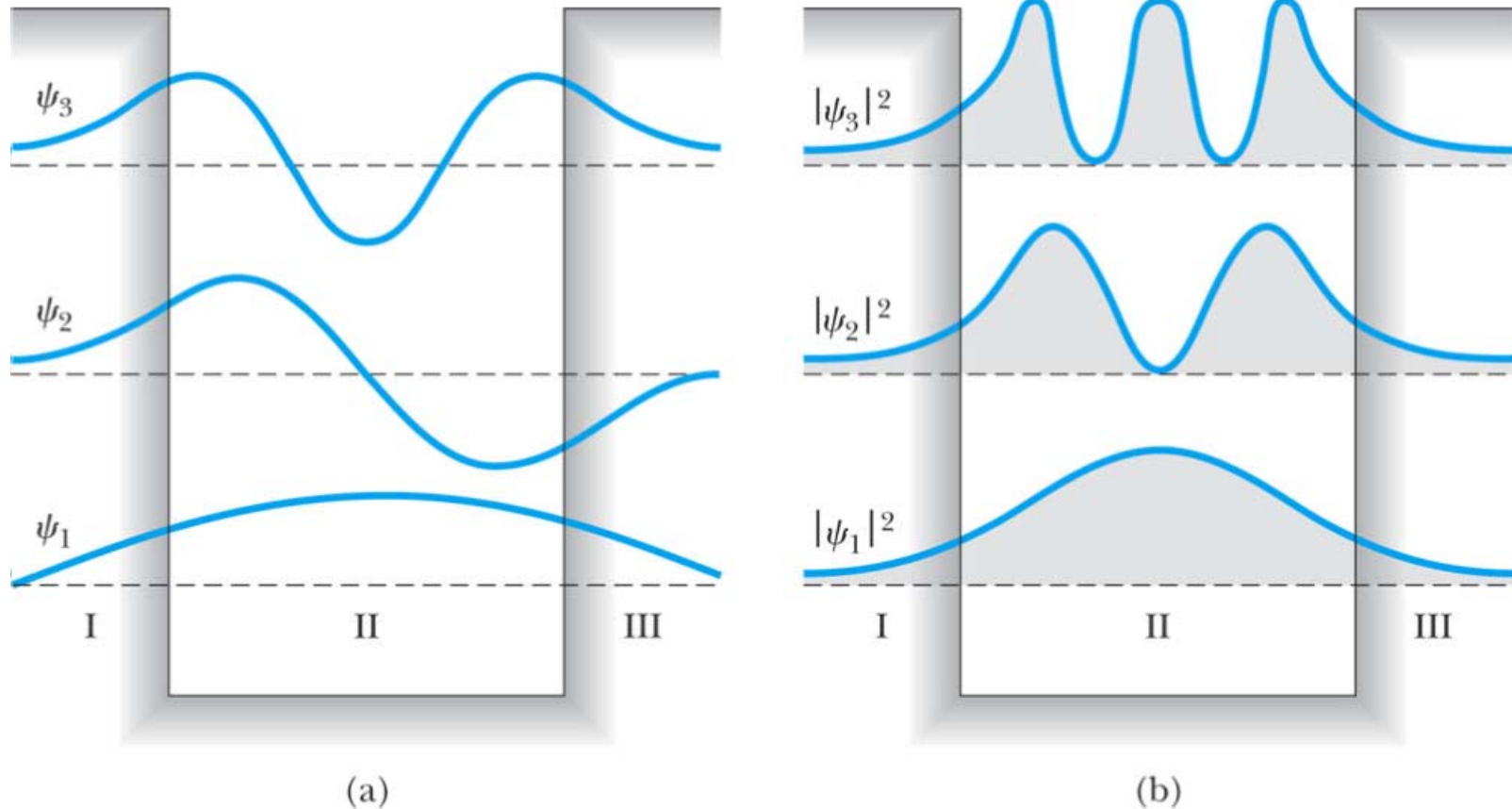

© 2005 Brooks/Cole - Thomson

Fig. 6-16, p. 210



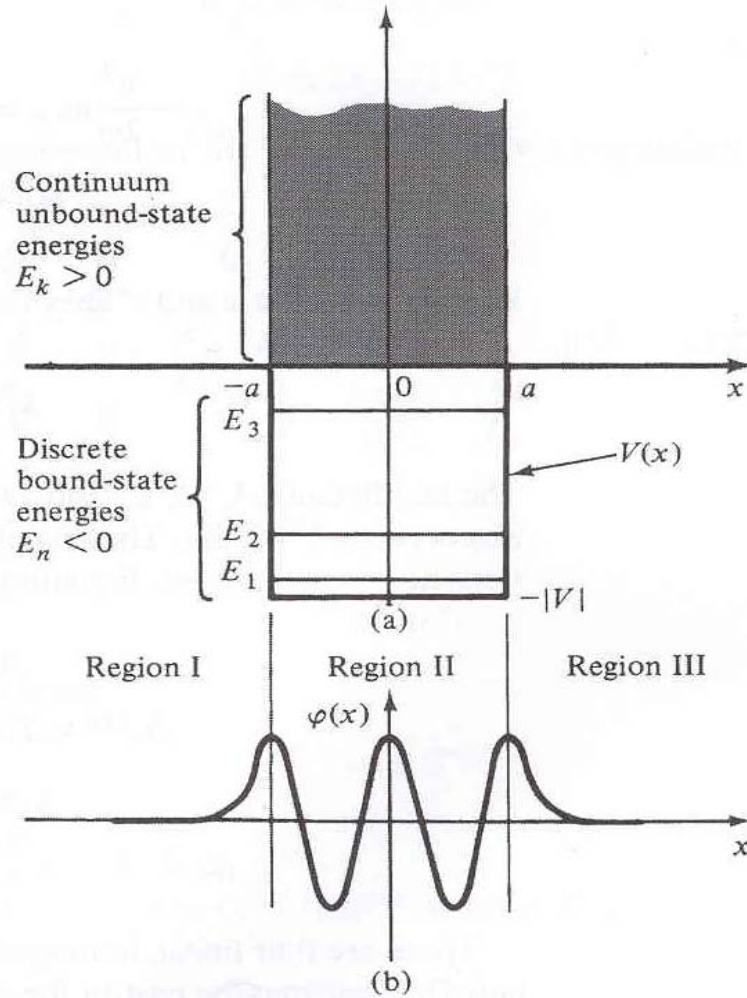

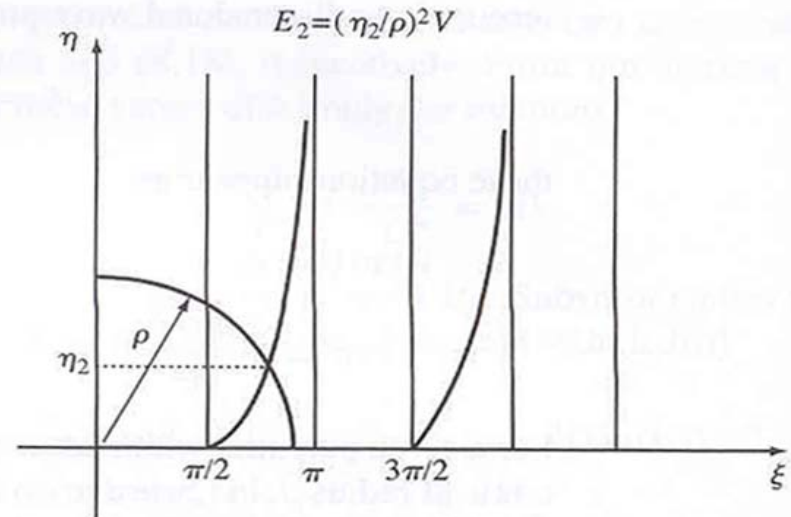
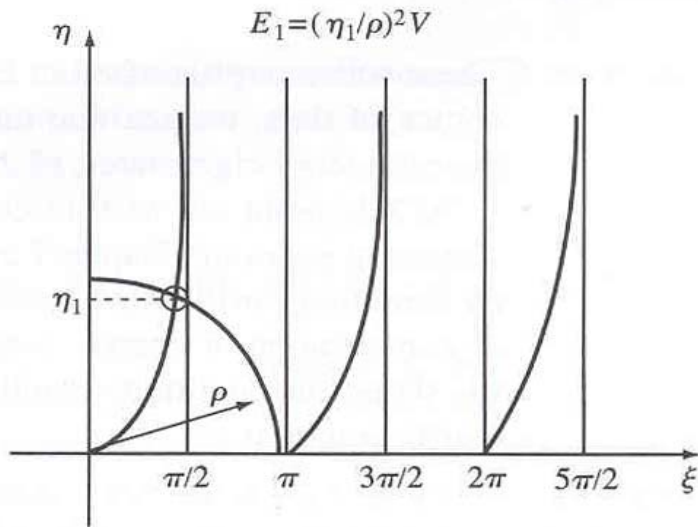

$$\rho^2 \equiv 2ma^2|V|/\hbar^2$$

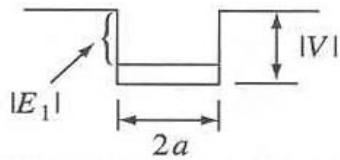

$$\rho^2 \equiv 2ma^2|V|/\hbar^2$$

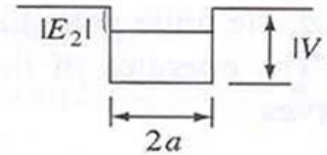

Bandgap Engineering

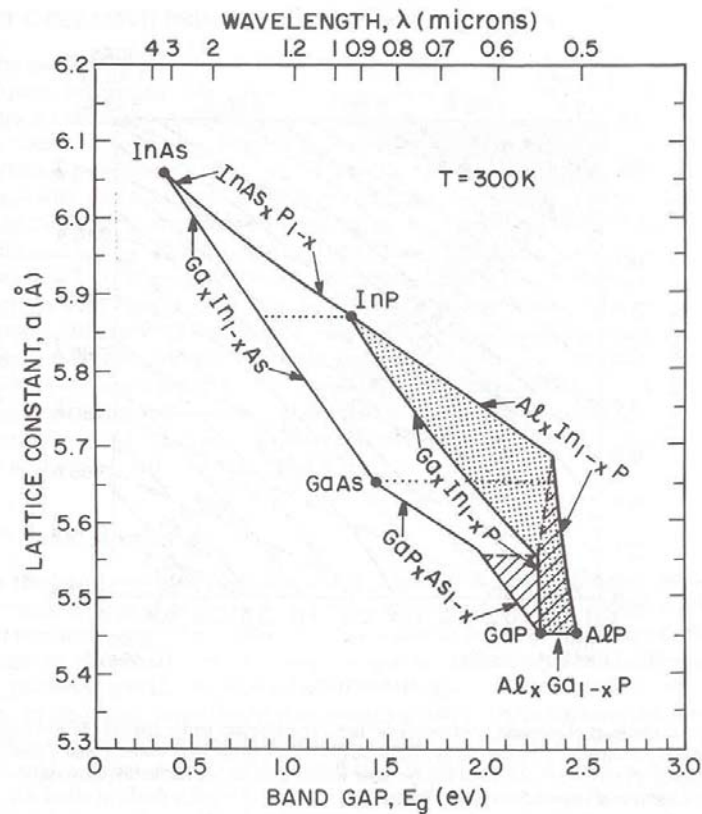

MBE (Molecular Beam Epitaxy)

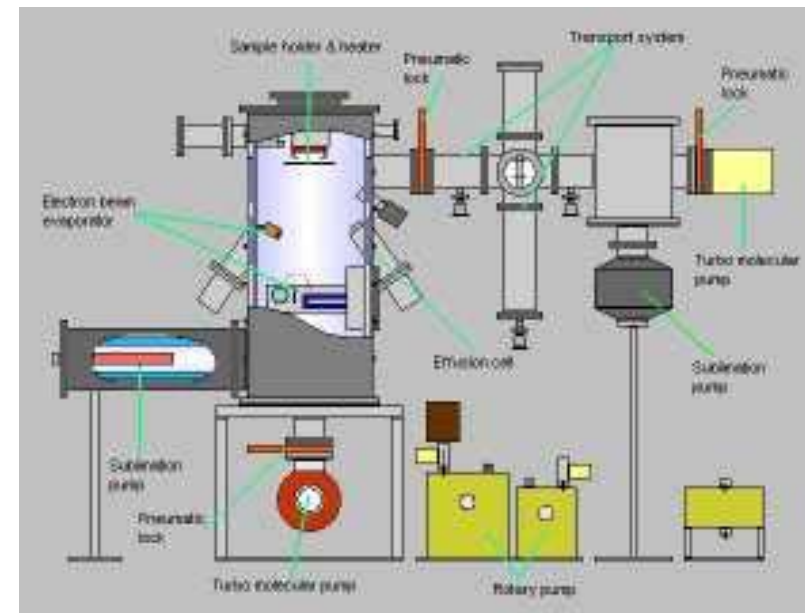

http://people.deas.harvard.edu/~jones/ap216/images/bandgap_engineering/bandgap_engineering.html



Quantum Well Devices

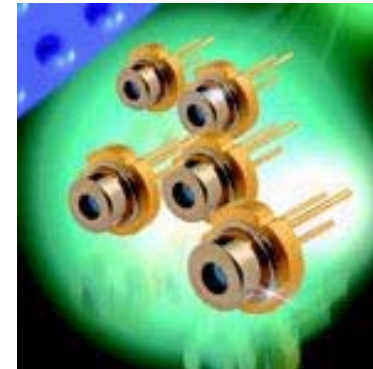
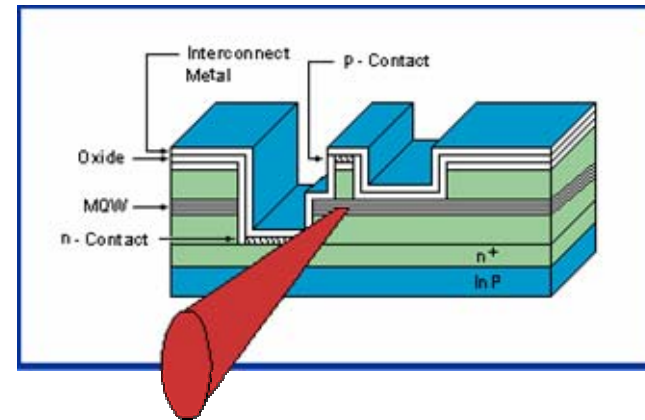
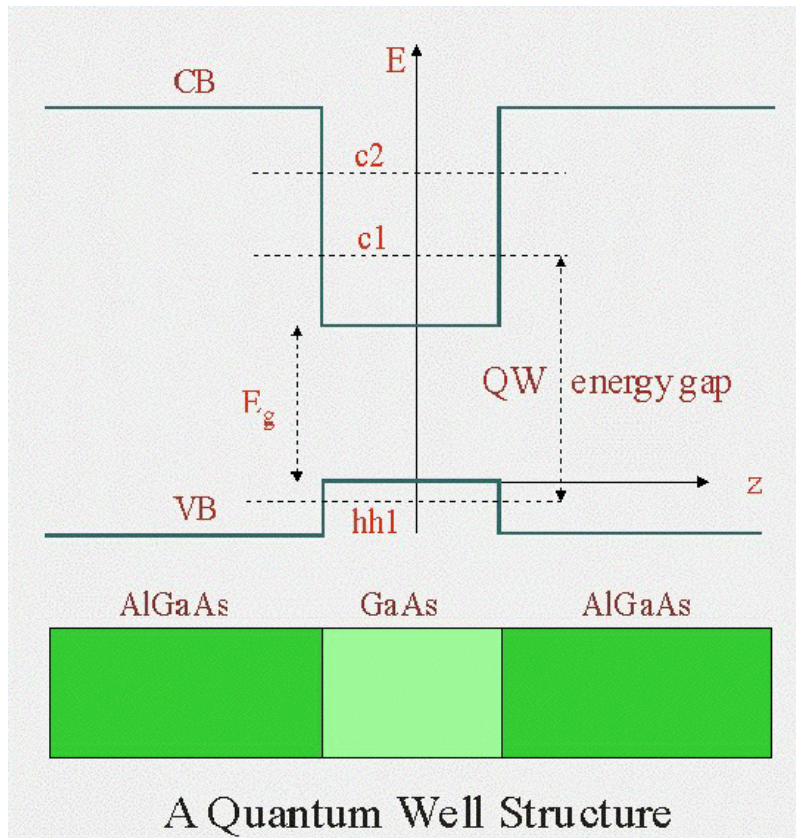

Multiple quantum well lasers



Quantum Well Devices

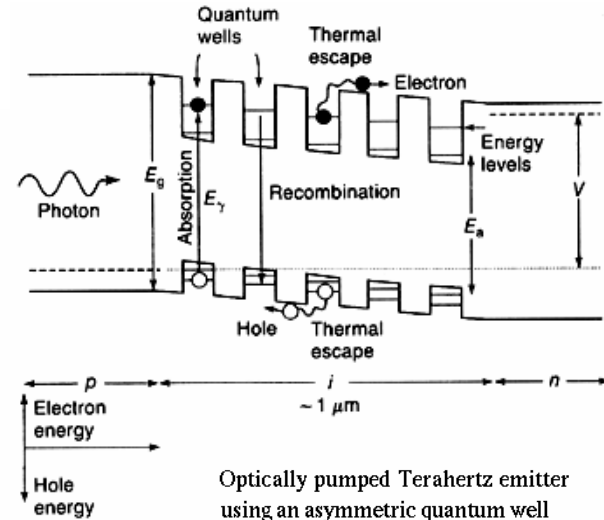
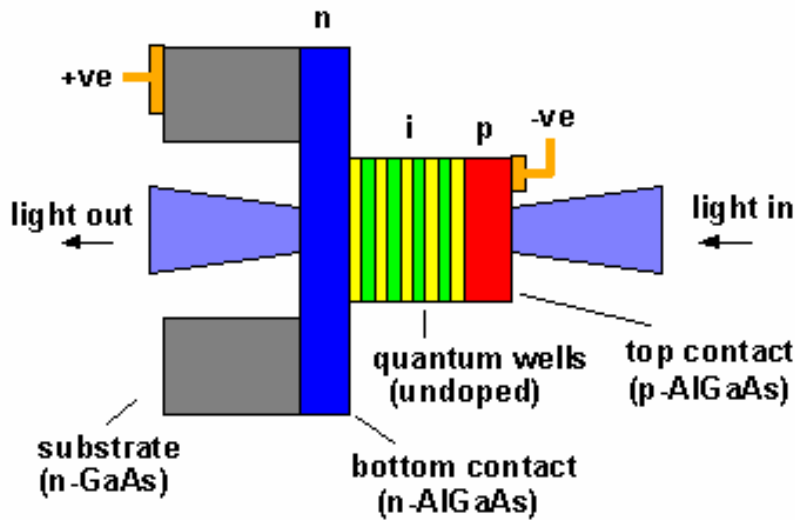

Optically pumped Terahertz emitter using an asymmetric quantum well

This diagram shows the wavefunctions of the electrons at the bottom of each of the three subbands in the well, with the zero amplitude of each wavefunction at the sub-band energy level.

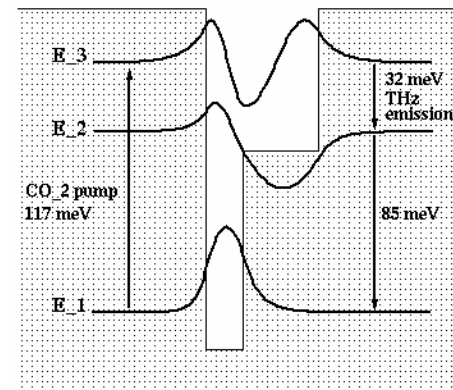

More Quantum – Quantum Wires and Quantum Dots

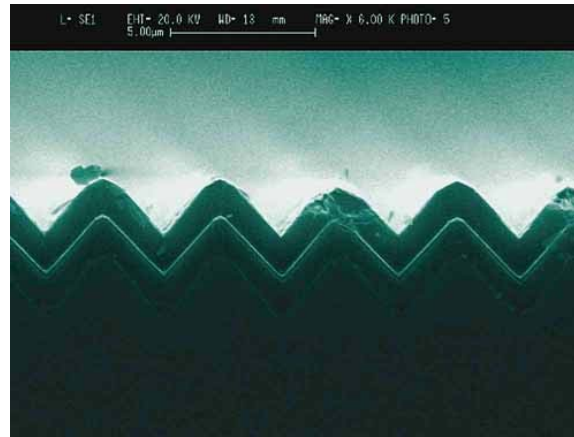
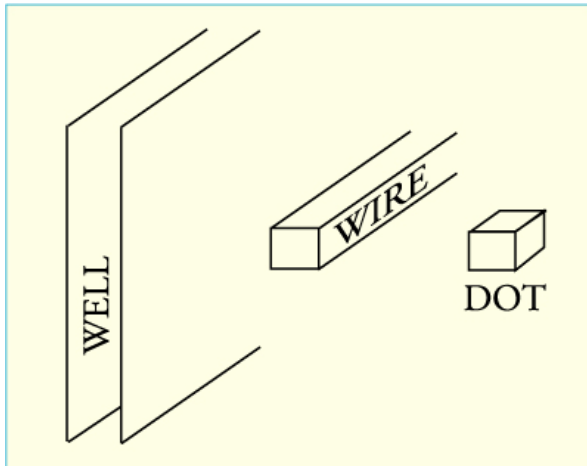

Quantum wire laser operating through the eye of a needle

<http://wwwrphysse.anu.edu.au/admin/pgbrochure/nano.html>

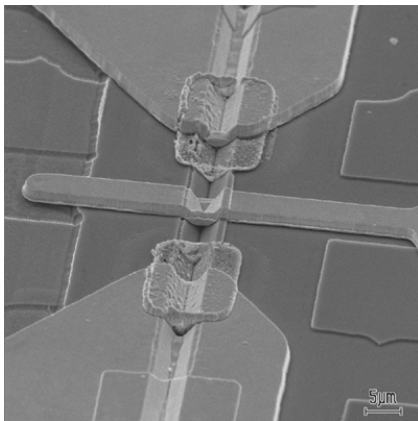

V-groove quantum wire field effect transistor

http://www.shef.ac.uk/eee/research/smd/research/quantum_fet.html

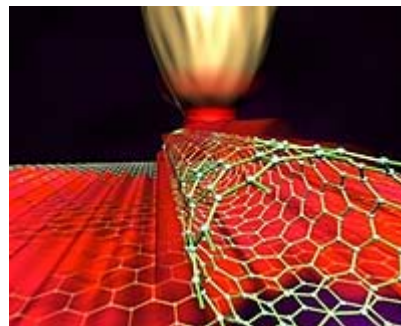

Carbon nanotube

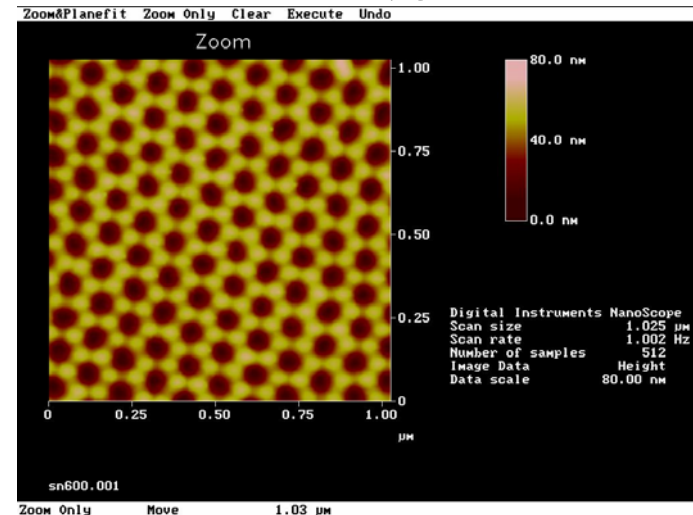

Average pore diameter is 52 nm.

<http://www.people.vcu.edu/~sbandy/project1.html>

