

Cryogenic Engineering

Chapter 8. Vacuum Technology

KIM, Min Soo

8.2 Flow regimes in vacuum systems

▪ Flow in low pressure

At low pressure, the gas molecules are so far apart that the gas cannot be treated as a continuous medium, and we obtain another flow regime

– ***free molecular flow***

The dimensionless parameter used to determine the dividing line between continuum and free-molecular flow is the ***Knudsen number***, $K_{Kn} = \lambda/D$

1. Continuum flow, $K_{Kn} < 0.01$
2. Mixed flow, $0.01 < K_{Kn} < 0.30$
3. Free-molecular flow, $0.30 < K_{Kn}$

λ : mean free path of the gas molecules

D : characteristic dimension of the flow channel

8.2 Flow regimes in vacuum systems

▪ Degree of vacuum

1. Rough vacuum, $25 \text{ torr} < P$
2. Medium vacuum, $10^{-3} \text{ torr} < P < 25 \text{ torr}$
3. High vacuum, $10^{-6} \text{ torr} < P < 10^{-3} \text{ torr}$
4. Medium vacuum, $10^{-9} \text{ torr} < P < 10^{-6} \text{ torr}$
5. Medium vacuum, $P < 10^{-9} \text{ torr}$

$$1 \text{ torr} = 133.322 \text{ Pa} = \frac{1}{760} \text{ atm}$$

8.3 Conductance in vacuum systems

For laminar continuum flow in a circular tube, Poiseuille's equation

$$\Delta p = 128\mu L \dot{m} / \pi D^4 \rho g_c$$

where L = tube length

D = tube diameter

$\bar{\rho}$ = mean fluid density

μ = fluid viscosity

Substituting $\bar{\rho} = \frac{\bar{p}M}{R_u T}$, where $\bar{p} = (p_1 + p_2)/2$

$$\Delta p = 128\mu L R_u T \dot{m} / \pi D^4 g_c \bar{p} M$$

8.3 Conductance in vacuum systems

According to kinetic theory of gases (Kennard 1938), the mass flow rate for mixed flow in a circular tube

$$\dot{m} = \frac{\pi D^4 g_c \bar{p} \Delta p}{128 \mu L R_u T} \left[1 + \frac{8 \mu}{\bar{p} D} \left(\frac{\pi R_u T}{2 g_c M} \right)^{1/2} \right]$$

For free-molecular flow in long tubes

$$\dot{m} = \left(\frac{\pi g_c M}{18 R_u T} \right)^{1/2} \left(\frac{D^3 \Delta p}{L} \right)$$

8.3 Conductance in vacuum systems

The throughput is commonly used in vacuum work

$$Q = p\dot{V} = \dot{m}R_u T/M$$

A conductance C for a vacuum element

$$C = Q/\Delta p = \dot{m}/\Delta p$$

8.3 Conductance in vacuum systems

The conductance for a long tube may be written as follows.

1. Laminar continuum flow

$$C = \pi D^4 g_c \bar{p} / 128 \mu L$$

2. Mixed flow

$$C = (\pi D^4 g_c \bar{p} / 128 \mu L) \left[1 + (8 \mu / \bar{p} D) \left(\frac{\pi R_u T}{2 g_c M} \right)^{1/2} \right]$$

3. Free molecular flow

$$C = (\pi g_c R_u T / 18 M)^{1/2} (D^3 / L)$$

8.4 Calculation of pump-down time for a vacuum system

One of the important factors in the design of a vacuum system is the determination of the pump-down time, or the time required to reduce the pressure of the system from ambient pressure to the desired operating pressure.

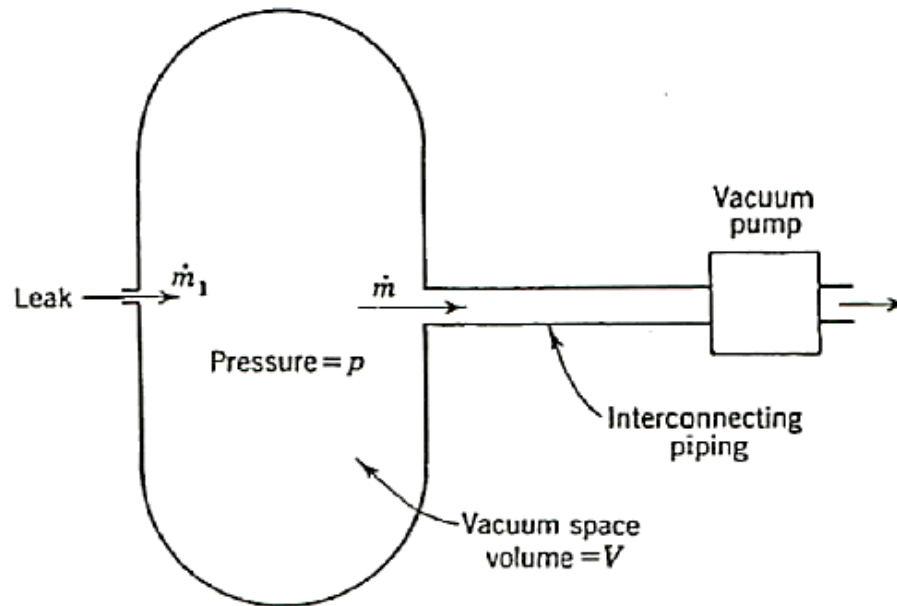

Vacuum system for pump-down equation development

8.5 Components of vacuum systems

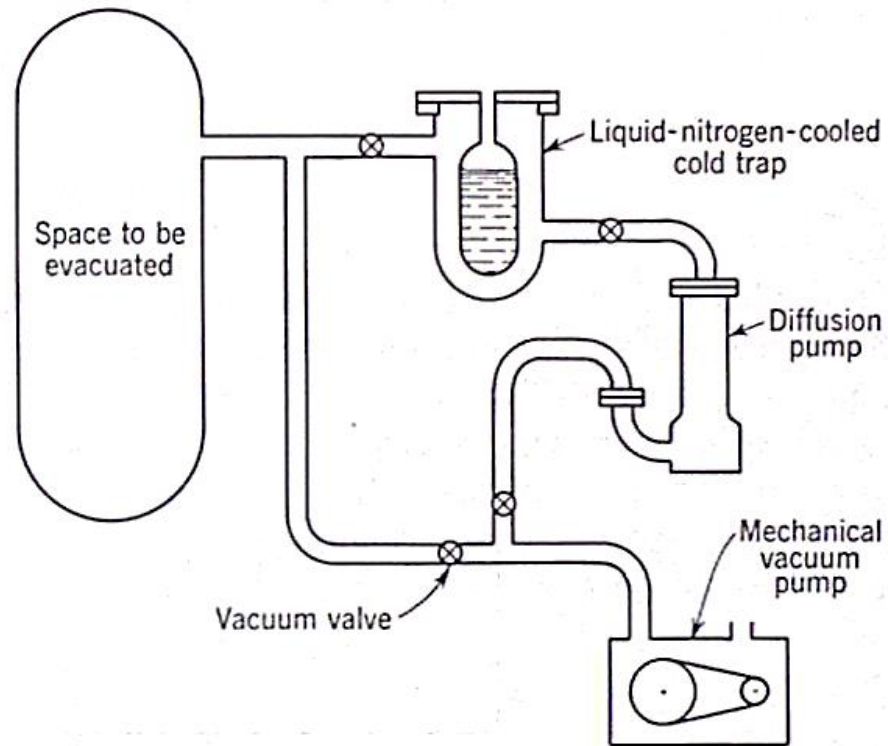

Basic elements of a typical vacuum system

8.5 Components of vacuum systems

- Mechanical vacuum pump is used as a forepump or roughing pump to reduce the system pressure to approx. 1.0Pa
- Diffusion pump operates if the pressure reduces about 1.0Pa – valve in the bypass line is closed
- Cold trap or baffle are provided near the inlet of the diffusion pump – preventing backstreaming of oil vapor, to freeze out condensable gases

8.6 Mechanical vacuum pumps

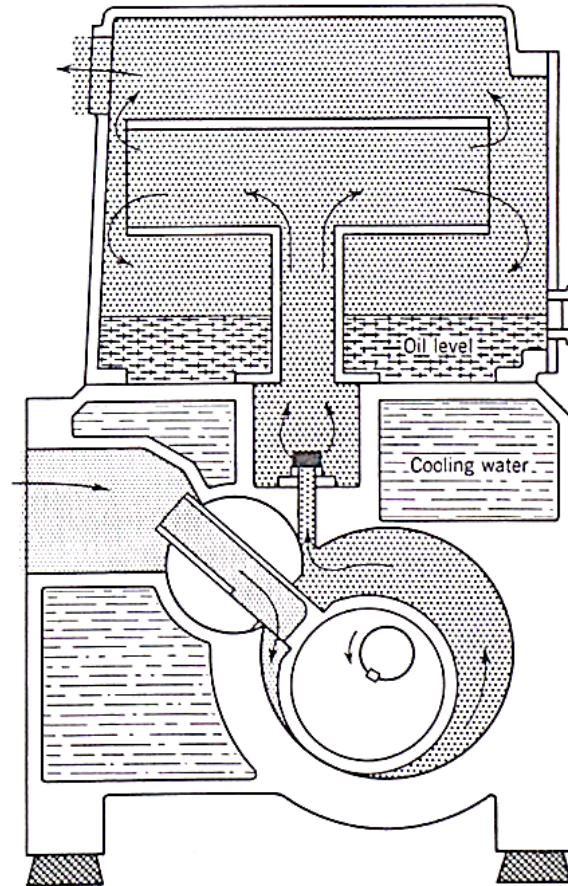

<Section view of a typical rotary-piston mechanical vacuum pump>

8.6 Mechanical vacuum pumps

- Basic principle – same as the rotary pump for higher pressures!
- Eccentric rotor(piston) rotates within the cylindrical jacket.
- Gas enters the space between the two cylinders is compressed to a higher pressure as the piston rotates.
- Gas is discharged through a check valve that prevents backflow of the air into the pump space.
- Oil separator is provided to remove the oil from the gas and return the oil to the pump.
- Gas Ballast – To prevent moisture condensation within the pump volume.
 - Admit sufficient atmospheric air into the pump space.

8.6 Mechanical vacuum pumps

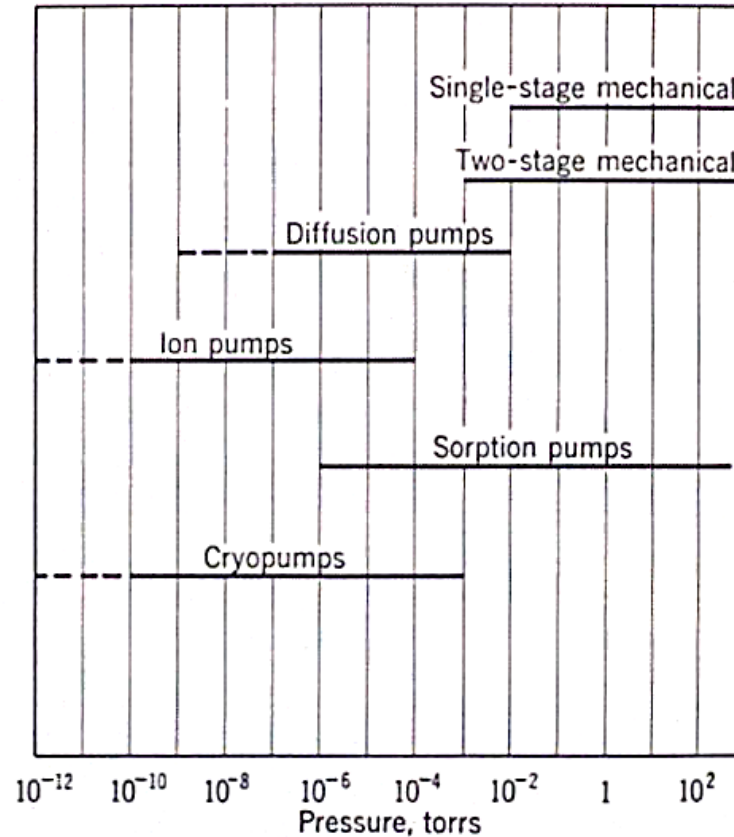

Operating range for various vacuum pumps

8.7 Diffusion pumps

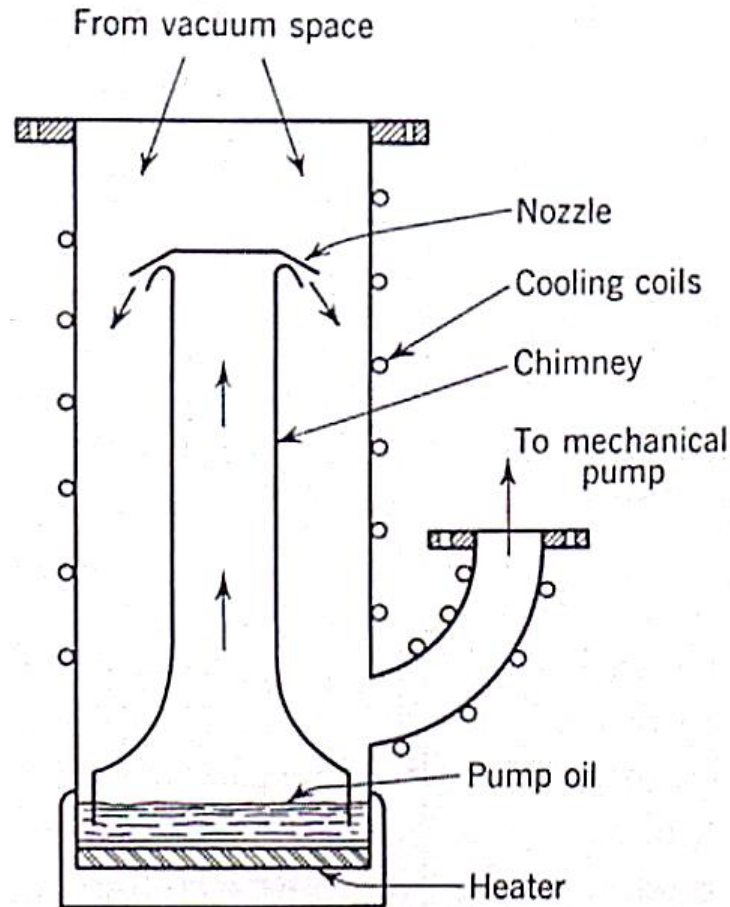

Schematic of a single-stage diffusion pump

8.7 Diffusion pumps

- Diffusion pumps – similar to the action of a steam ejector pump.
- Ordinarily operates in the free-molecular flow regime rather than the continuum regime.
- Working fluid is evaporated in the boiler at the bottom, flows up the chimney, vapor is ejected at high velocities in a downward direction from vapor jets.
- Vapor molecules strikes gas molecules – force the gas molecules downward and out the pump exhaust.
- Vapor molecules are condensed and returned to the boiler.
- Gas molecules – removed by a mechanical backing pump.

8.7 Diffusion pumps

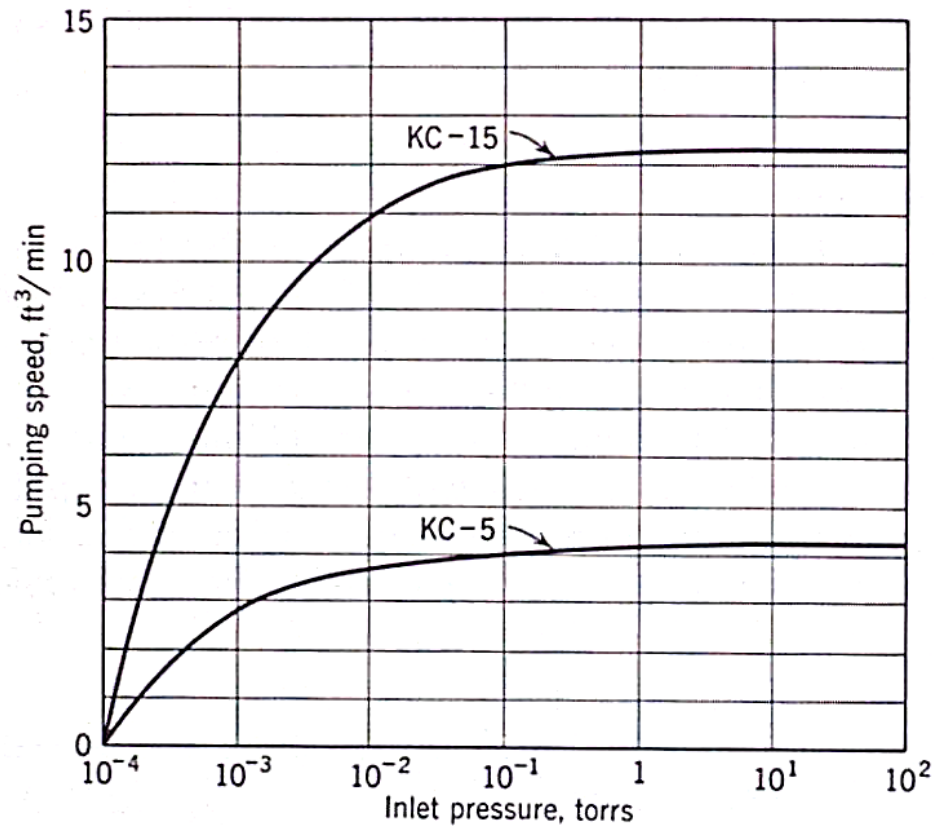

Pumping speed curves for mechanical vacuum pumps

8.7 Diffusion pumps

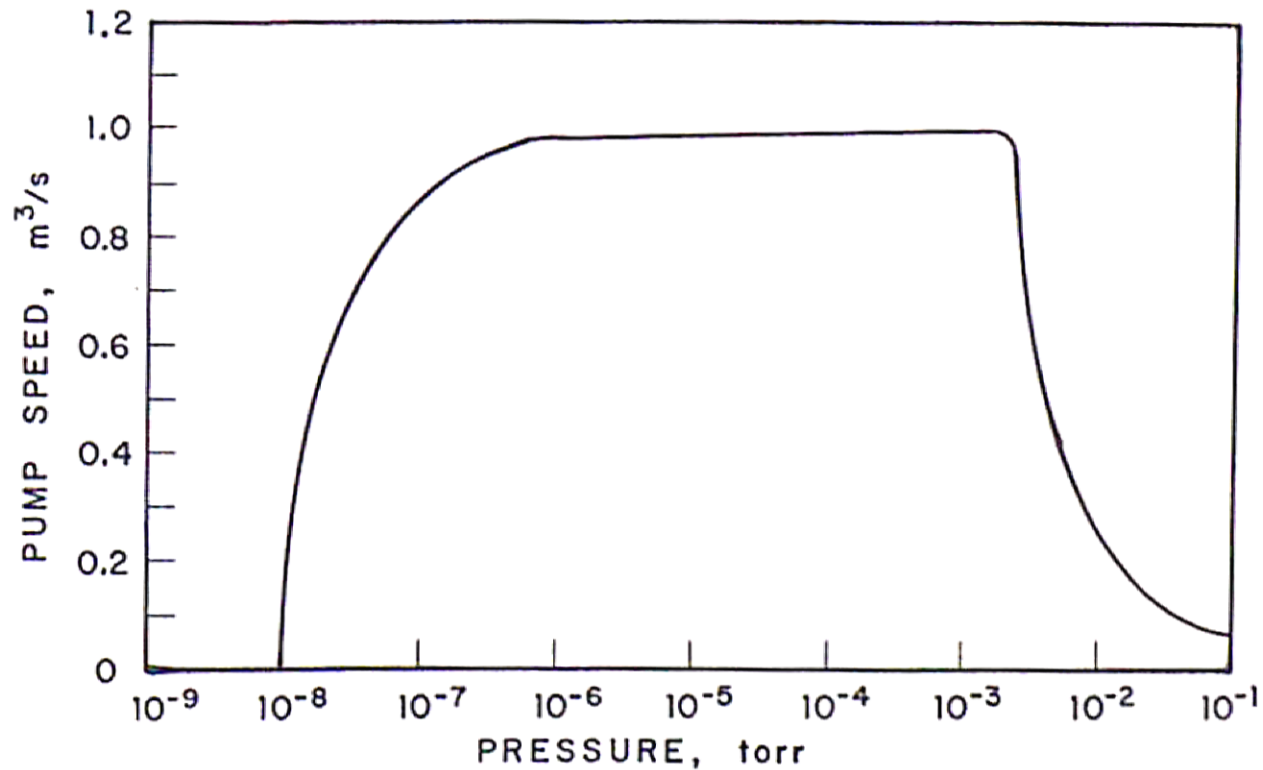

Pumping-speed curve for a diffusion pump having a nominal diameter of 100mm(4in)

8.7 Diffusion pumps

Ideal case, a diffusion pump should remove gas molecules as fast as they diffuse into the pump inlet

→ maximum pumping speed is the same as the conductance of an aperture!

$$S_p^0 = \left(\frac{\pi g_c R_u T}{32M} \right)^{1/2} D^2$$

8.7 Diffusion pumps

The ratio of the actual pump speed to the theoretical pump speed is called the H_0 coefficient

$$S_p = H_0 S_p^0$$

Typical H_0 coefficients for commercial vacuum pumps range between 0.40~0.55.

8.8 Ion pumps

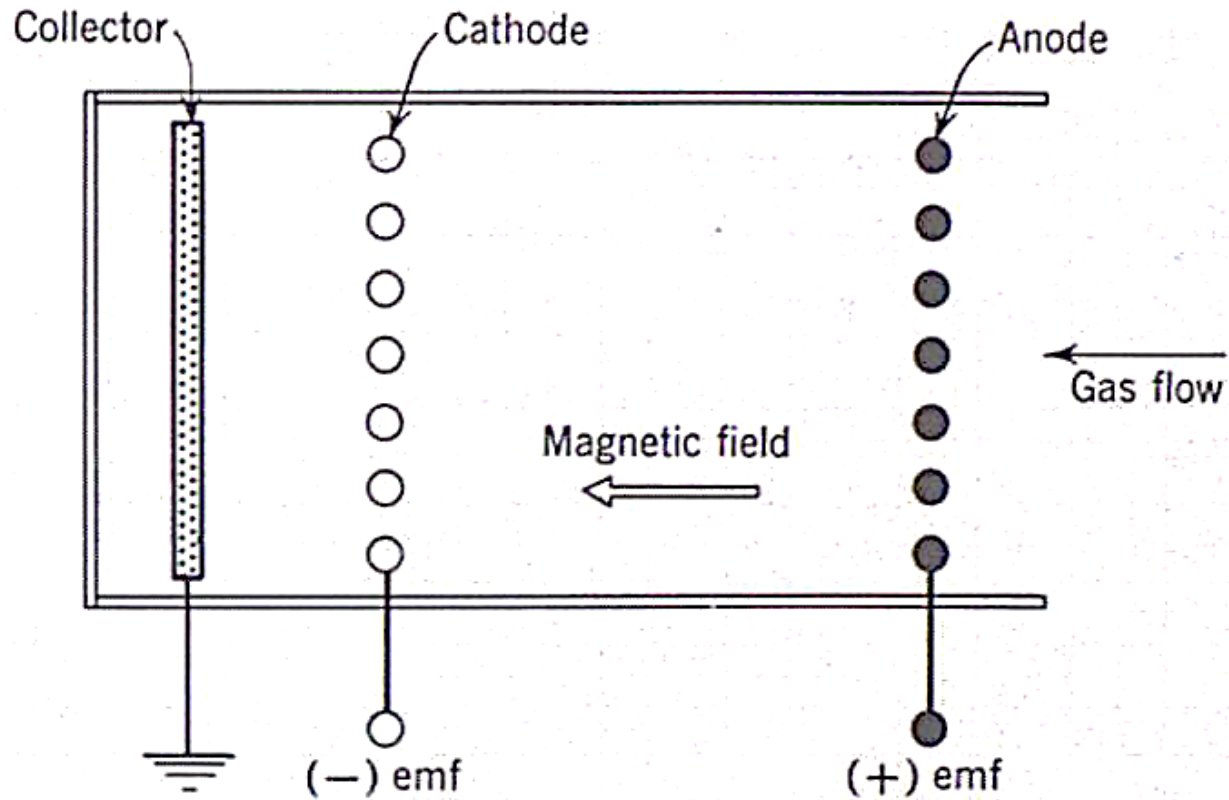

Schematic of an ion pump

8.8 Ion pumps

Ion pump structure :

- Combination of ionization and chemisorption
- A large positive electric potential – Anode, a large negative electric potential – Chathode
- Magnetic field is applied to the entire unit

8.8 Ion pumps

- Electrons from cathode – attracted to the anode
- Due to the magnetic field, electrons moves cycloidal path
- Collision supplies more free electrons
- Positive ion – attracted to the Cathode
- Remainder of the ions bombard the cathode and tear out
- Sputtered material buries the gas ions
- The gas ions are driven to the collector
- The Ion pump has relatively high pumping efficiency!

8.9 Cryopumping

Condensation of a gas on a cryogenically cooled surface to produce a vacuum is called “Cryopumping”

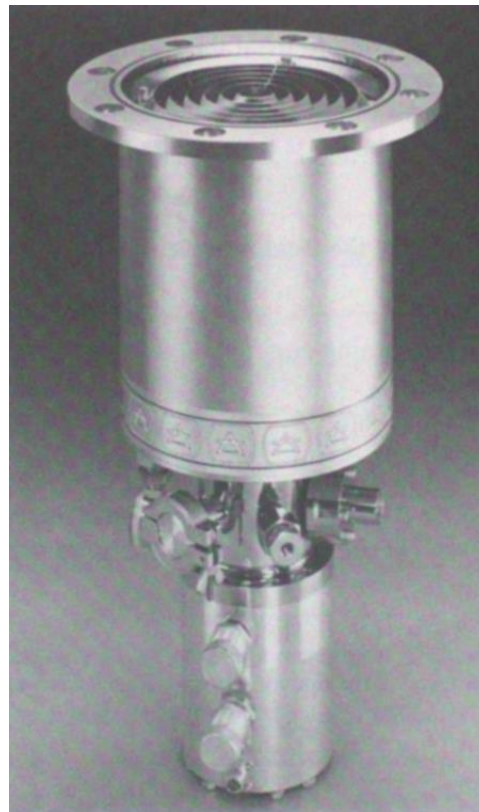

Air products Model AP-8S cryopump

8.9 Cryopumping

- The cryopumping phenomenon
: Phase change from gas to solid at the cold surface + adsorption of the gas molecules.
- Extremely large pumping speeds
- Pump is placed within the space to be evacuated
: The resistance of the interconnecting piping is eliminated.

8.9 Cryopumping

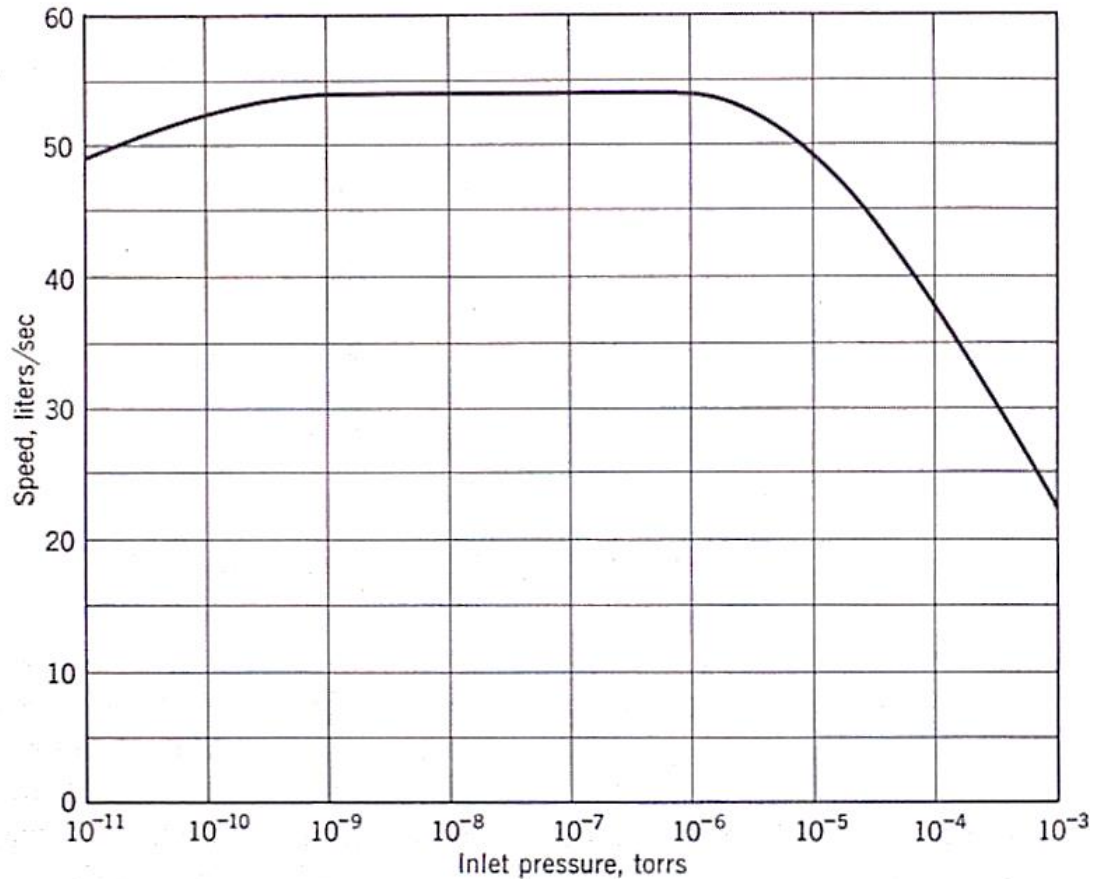

Pumping-speed curve for an ion pump

8.9 Cryopumping

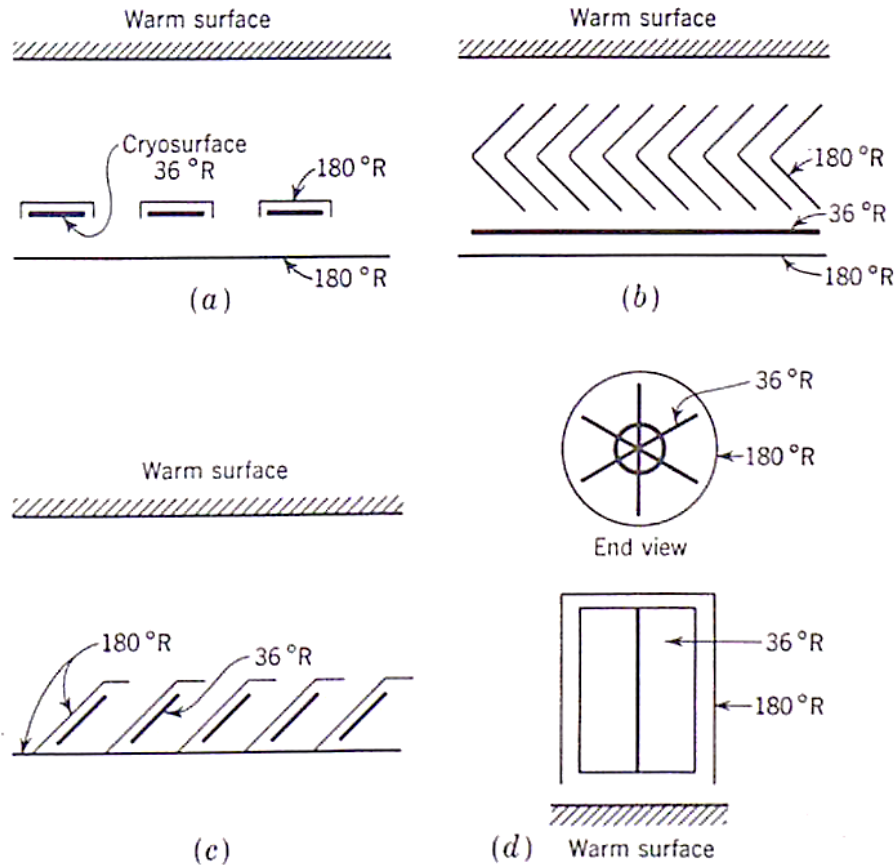

Cryopump arrays – (a)Plate-shield array;(b)Chevron-shielded array;(c)Santler array;(d)Cryopump for high-velocity wind-tunnel cryopumping

8.9 Cryopumping

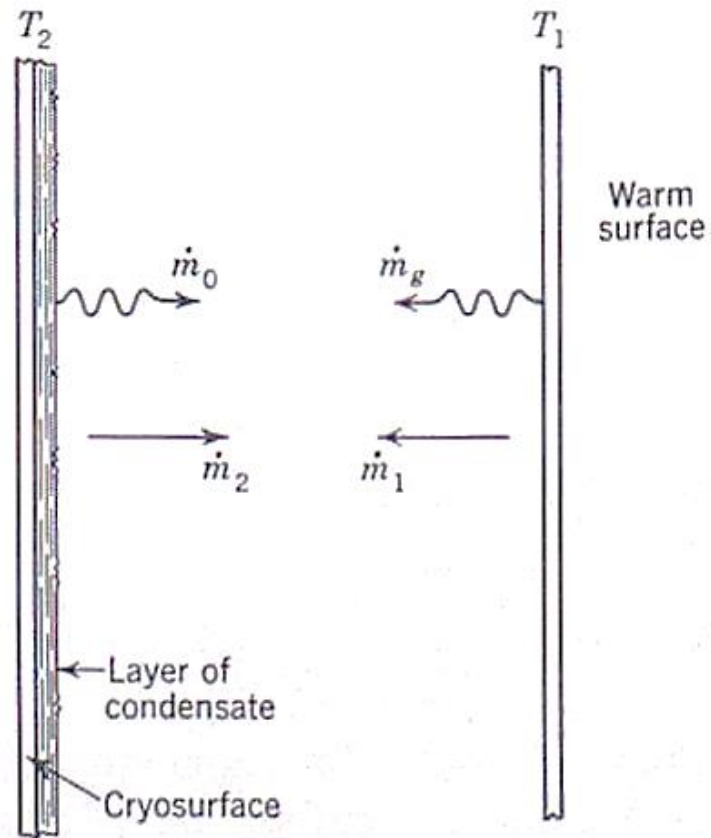

Parallel-plate cryopump system

8.9 Cryopumping

General expression for the pumping speed of the parallel-plate cryopump :

$$\frac{S_p}{A} = \frac{\left(\frac{2g_c R_u T_1}{\pi M}\right)^{\frac{1}{2}} \left(1 - \frac{p_u}{p}\right) f}{1 + \left(\frac{p_u}{p}\right) \left[\left(\frac{T_1}{T_2}\right)^{\frac{1}{2}} - 1\right] + G}$$

$$G = (1 - f) \left(\frac{T_1}{T_2}\right)^{1/2} \left\{ 1 - \left(\frac{p_u}{p}\right) \left[1 - \left(\frac{T_2}{T_1}\right)^{\frac{1}{2}} \right] \right\}$$

8.9 Cryopumping

For the special case of unity sticking coefficient, $f = 1$, the parameter $G = 0$

$$\left(\frac{S_p}{A}\right)_{f=1} = \left(\frac{2g_c R_u T_1}{\pi M}\right)^{\frac{1}{2}} \frac{\left(1 - \frac{p_u}{p}\right)}{1 + \left(\frac{p_u}{p}\right) \left[\left(\frac{T_1}{T_2}\right)^{\frac{1}{2}} - 1\right]}$$

8.9 Cryopumping

Determining the sticking coefficient f ,

$$f = 0.453 + 0.256 \log_{10} M \quad (\text{for } M \leq 137 \text{ g/mol})$$
$$f = 1 \quad (\text{for } M > 137 \text{ g/mol})$$

8.9 Cryopumping

Table 8.4. Measured values of the sticking coefficient f

Gas Being Pumped	Cryosurface Temperature (K)	Warm-Surface Temperature (K)	Sticking Coefficient f	Reference
Ammonia	77.3	300	0.45	Brown and Wang 1965
Argon	20	77.3	0.79	Dawson et al. 1964
CO ₂	77.3	300	0.62	Brown and Wang 1965
CO ₂	20	195	0.90	Dawson et al. 1964
CO ₂	77.3	195	0.80	Dawson et al. 1964
CO ₂	20.2	300	0.65	Dawson et al. 1964
CO ₂	77.3	300	0.63	Dawson et al. 1964
CO ₂	21.0	400	0.44	Dawson et al. 1964
CO ₂	77.3	400	0.49	Dawson et al. 1964
Nitrogen	20	...	0.55	Moore 1962
Nitrogen	20	85	0.73	Hurlbut and Mansfield 1963
Nitrogen	20	77.3	0.87	Dawson et al. 1964
Water	77.3	300	0.92	Brown and Wang 1965

Measured values of the sticking coefficient f

8.9 Cryopumping

In cryopumping-array calculations, the parameter *capture coefficient* C_c is utilized.

$$\frac{S_p}{A} = \frac{C_c}{2 - C_c} \left(\frac{2g_c R_u T_1}{\pi M} \right)^{\frac{1}{2}} \left(1 - \frac{p_u}{p} \right)$$

8.9 Cryopumping

Table 8.5. Capture coefficients C_c for various cryopump configurations when pumping air (or nitrogen)

Cryopump Configuration	Capture Coefficient C_c	Reference
Arrangement (a), Fig. 8.9	0.25	A. D. Little 1960
Arrangement (b), Fig. 8.9	0.27	A. D. Little 1960
Arrangement (c), Fig. 8.9	0.45	A. D. Little 1960
Arrangement (d), Fig. 8.9	0.79	Barnes and Hood 1962
NRC Modular Cryopump	0.26	Hoening 1964
Air Products AP-8S	0.31	Bentley 1980

Capture coefficients C_c for various cryopump configurations when pumping air(or nitrogen)

8.9 Cryopumping

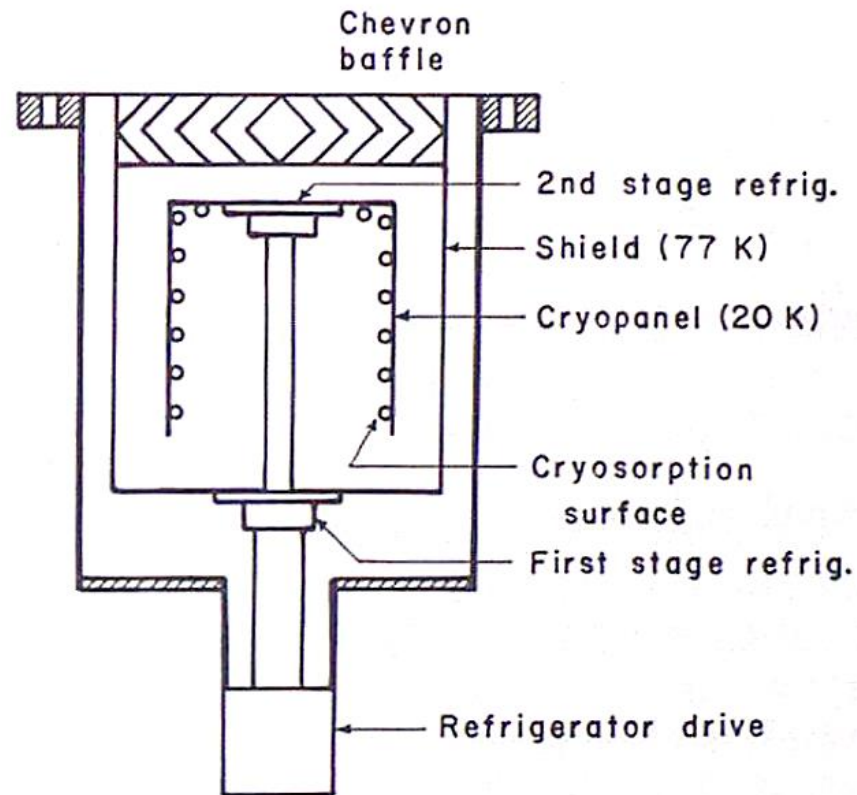

Schematic of a cryosorption pump

8.10 Getters and sorption pumps

Getters are materials that remove residual gases in a vacuum system by one or a combination of the three sorption processes:

- (1) Physical adsorption
- (2) absorption
- (3) chemisorption

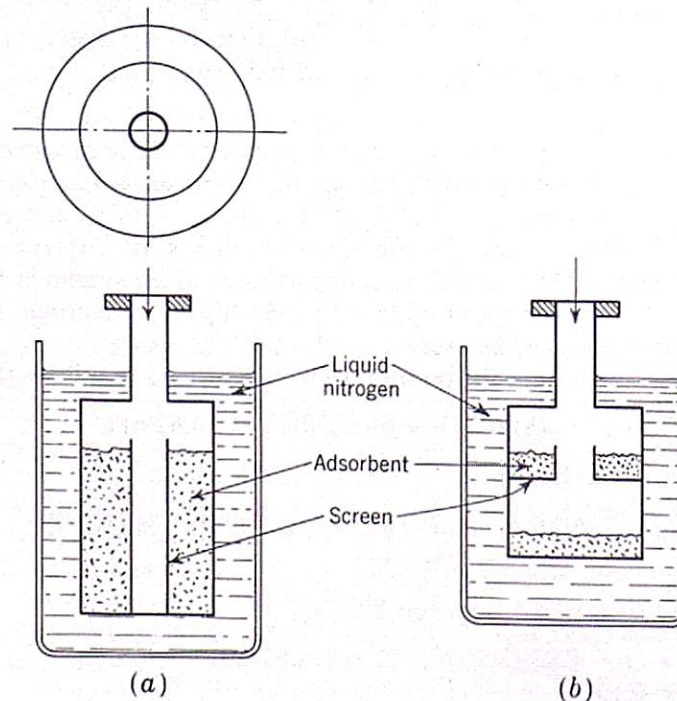

Typical sorption pumps

8.11 Baffles and cold traps

Baffles are cooled surfaces placed near the inlet of a vacuum pump to prevent back streaming of the pump fluid into the vacuum space.

A **cold trap** is similar to a baffle, but the cold trap is always refrigerated by a cryogenic fluid or dry ice to condense and capture both oil-vapor molecules and any other condensable gases.

8.11 Baffles and cold traps

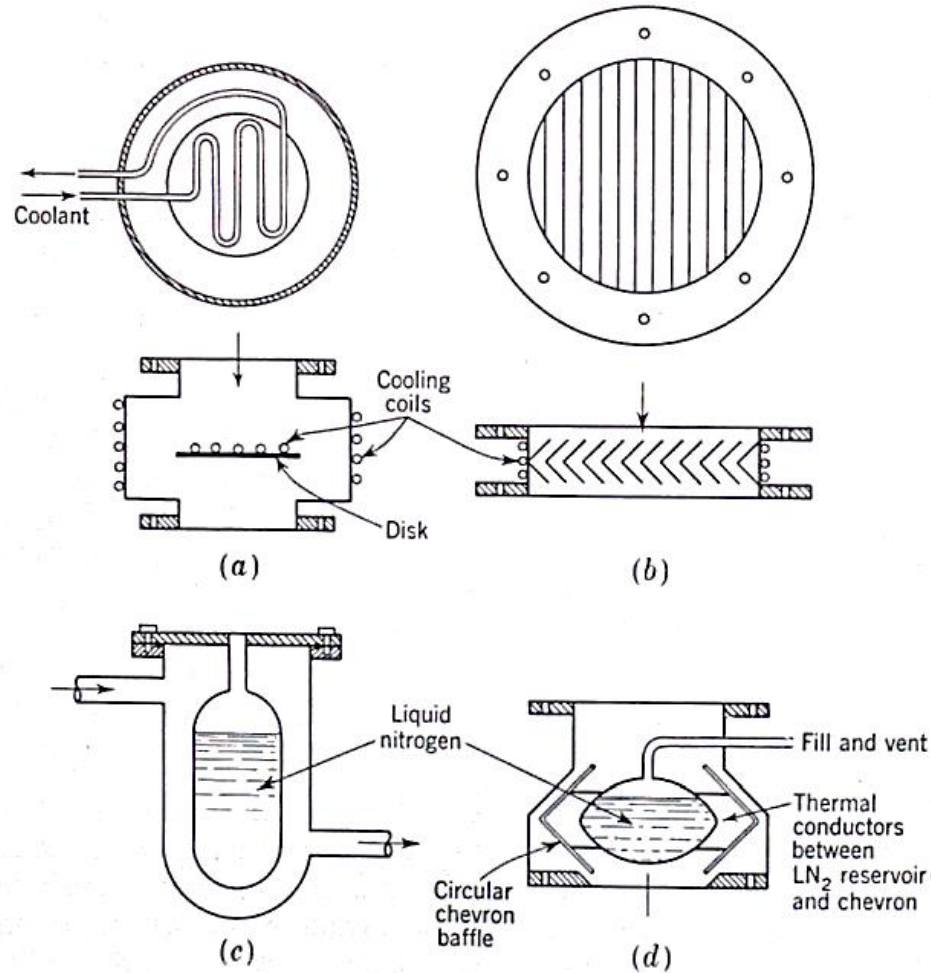

Baffles and cold traps. (a) Disc baffle; (b) chevron baffle; (c) simple cold trap; (d) combination baffle and cold trap

8.12 Vacuum gauges

Because pressures measured by vacuum gauges are several orders of magnitude smaller than atmospheric pressure, most of the ordinary pressure gauges cannot be easily used in vacuum work.

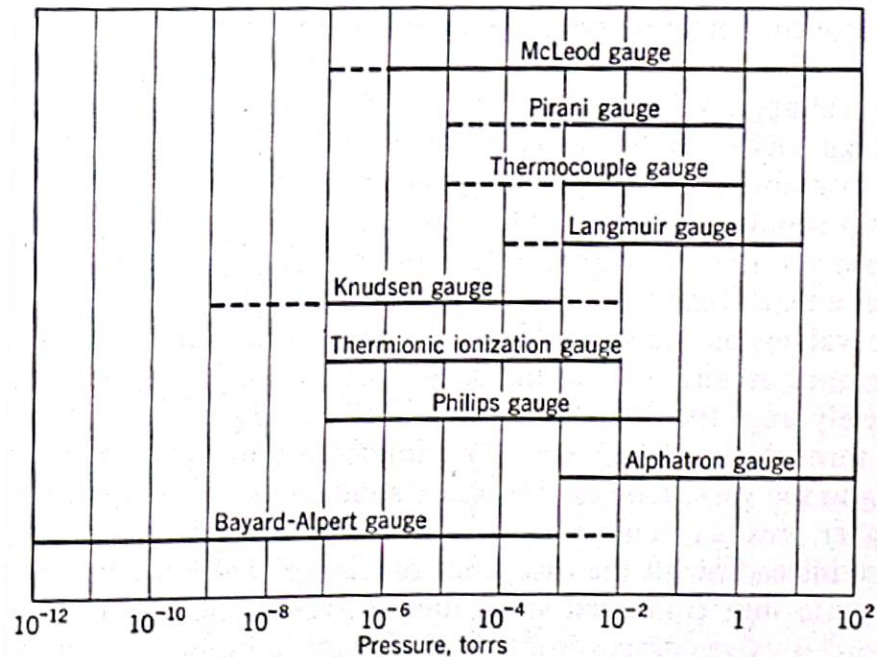

Operating range for various vacuum gauges

8.13 Vacuum valves

Valves used in vacuum systems require:

- (1) Freedom from leakage under high vacuum
- (2) Maximum conductance
- (3) Absence of outgassing

8.13 Vacuum valves

Angle valves have a relatively high conductance because the closing disc can be withdrawn completely from the flow passage.

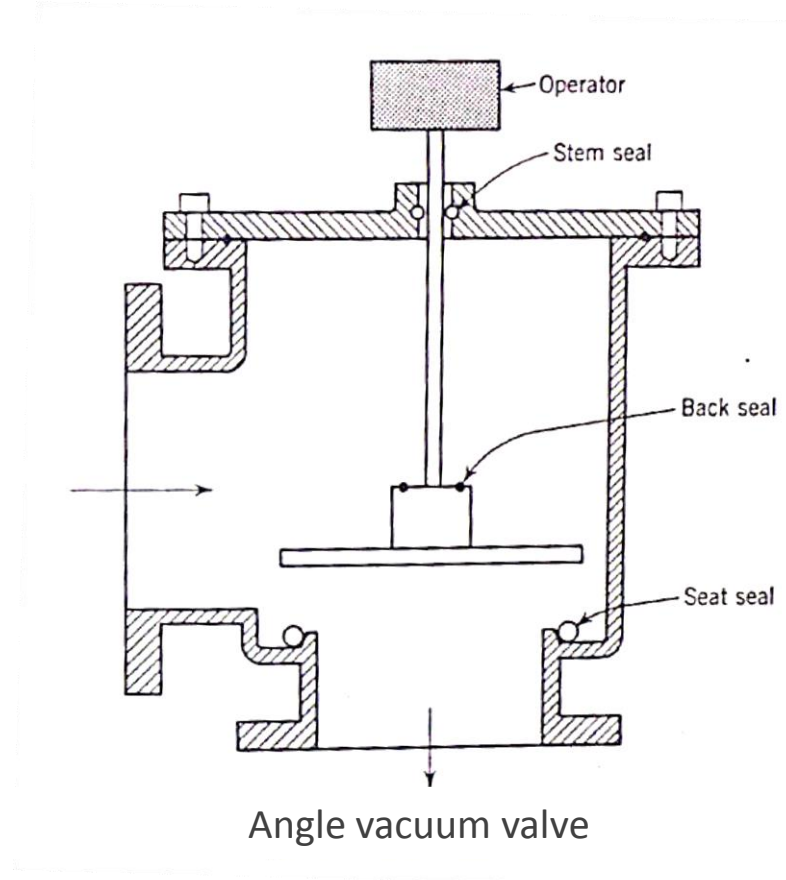

8.13 Vacuum valves

Slide valves have an in-line design and high conductance because the closing portion of the valve may be withdrawn completely from the flow passage.

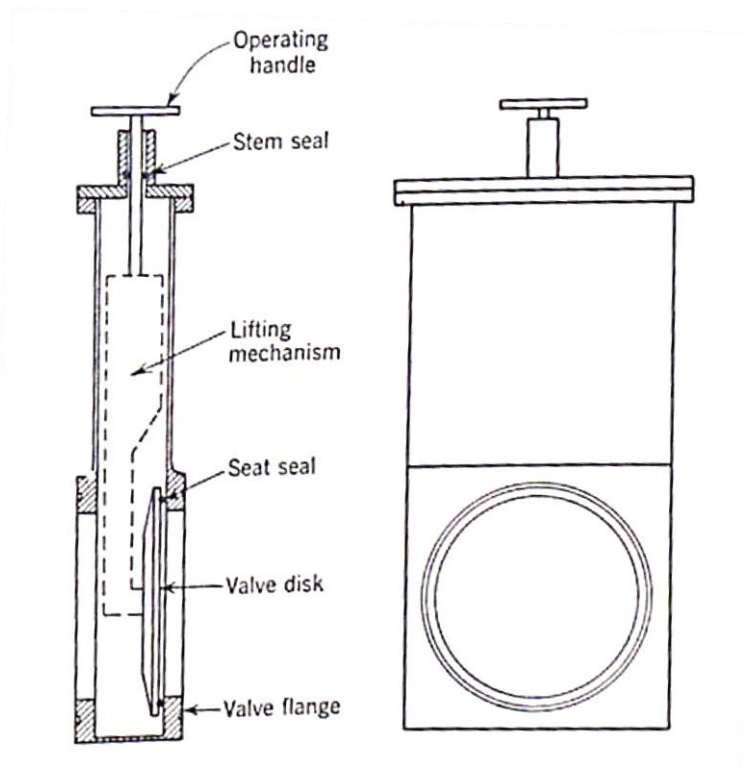

Slide valve for high-vacuum service

8.13 Vacuum valves

Ball valves are a form of stopcock. The valve consists of a sphere with a hole drilled through it.

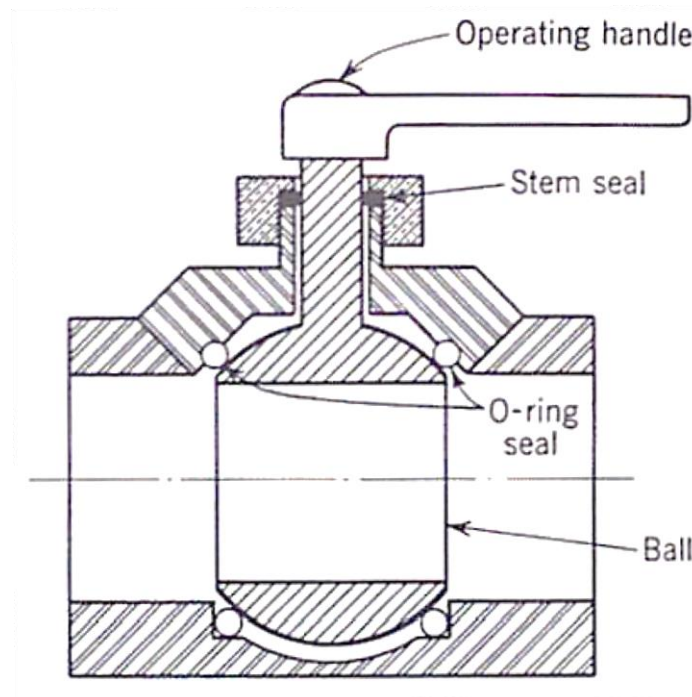

Ball valve

8.13 Vacuum valves

The diaphragm valve is a vacuum valve of somewhat lower conductance and lower performance than the valves previously mentioned.

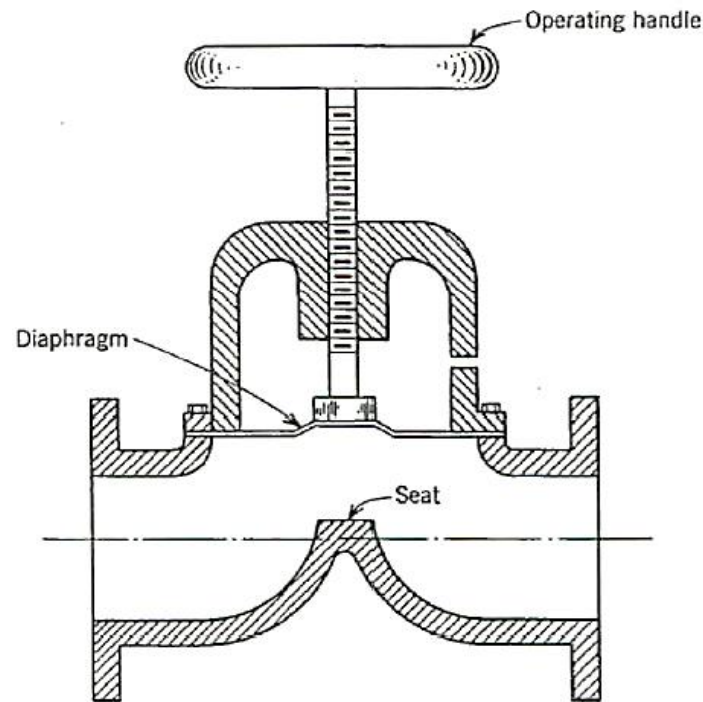

Diaphragm valve