

Decentralized wastewater systems

Today's class

- Paradigm shift of urban sanitation & metabolism
- Source separation and decentralization
- Challenges of wastewater management decentralization
- Self organization

Paradigm shift of urban sanitation

- **1st generation: removal of BOD**
 - 1960-1990 in developed countries, 1990-2000s in Korea
 - Construction of sewers and centralized wastewater treatment plants
 - Highly subsidized by federal and state agencies
 - Took about 30 yrs for BOD removal from 10% to ~90%



Paradigm shift of urban sanitation

- **2nd generation: improved effluent quality, including nutrient (N, P) removal**
 - Mainly to deal with eutrophication problems (algal bloom)

- **3rd generation??**

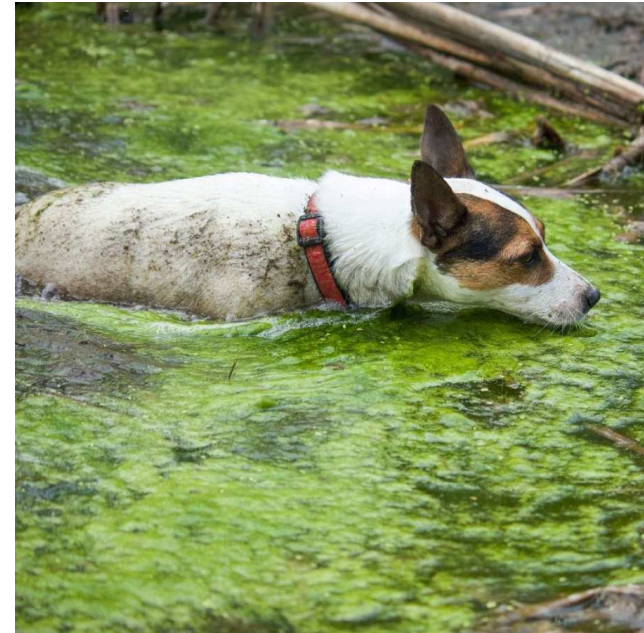

Current issues of urban sanitation

- **Rapid urbanization**

- Rapid population growth
(~20 billion in early 20c → ~70 billion current)
- Most people dwell in urban areas
(~20% in early 20c → ~50% current)
- Rapid population growth
- Limited budget to construct water infrastructure in developing countries
- Projection of population in rapidly growing cities is challenging: overloading sewers
 - Frequent flooding of sewers
 - Permanently active CSOs
(combined sewer overflow)
- Water scarcity problems

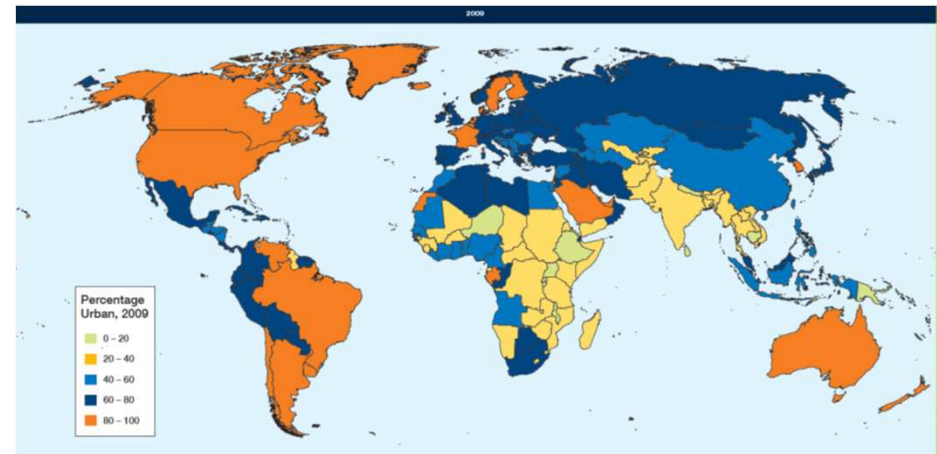
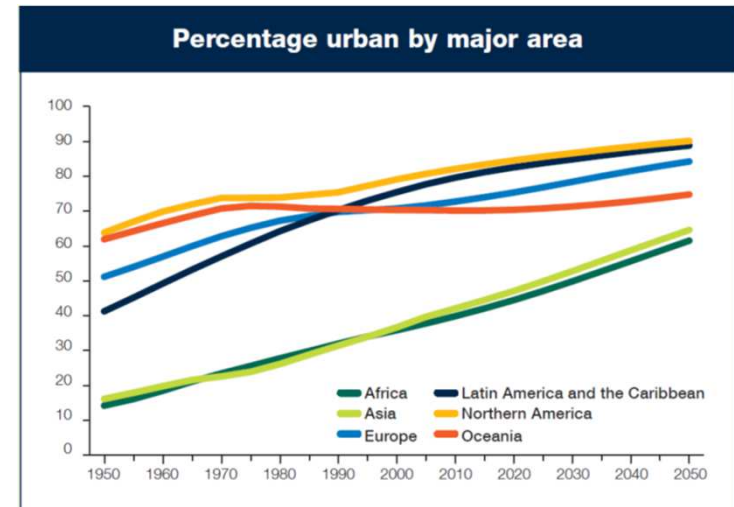

Current issues of urban sanitation

- **Sustainability issues**

Need for

- Low energy consuming (or energy-neutral, net energy-producing) facilities
- Restore water cycle in urban areas
- Facilities with lower carbon footprint



Current urban metabolism

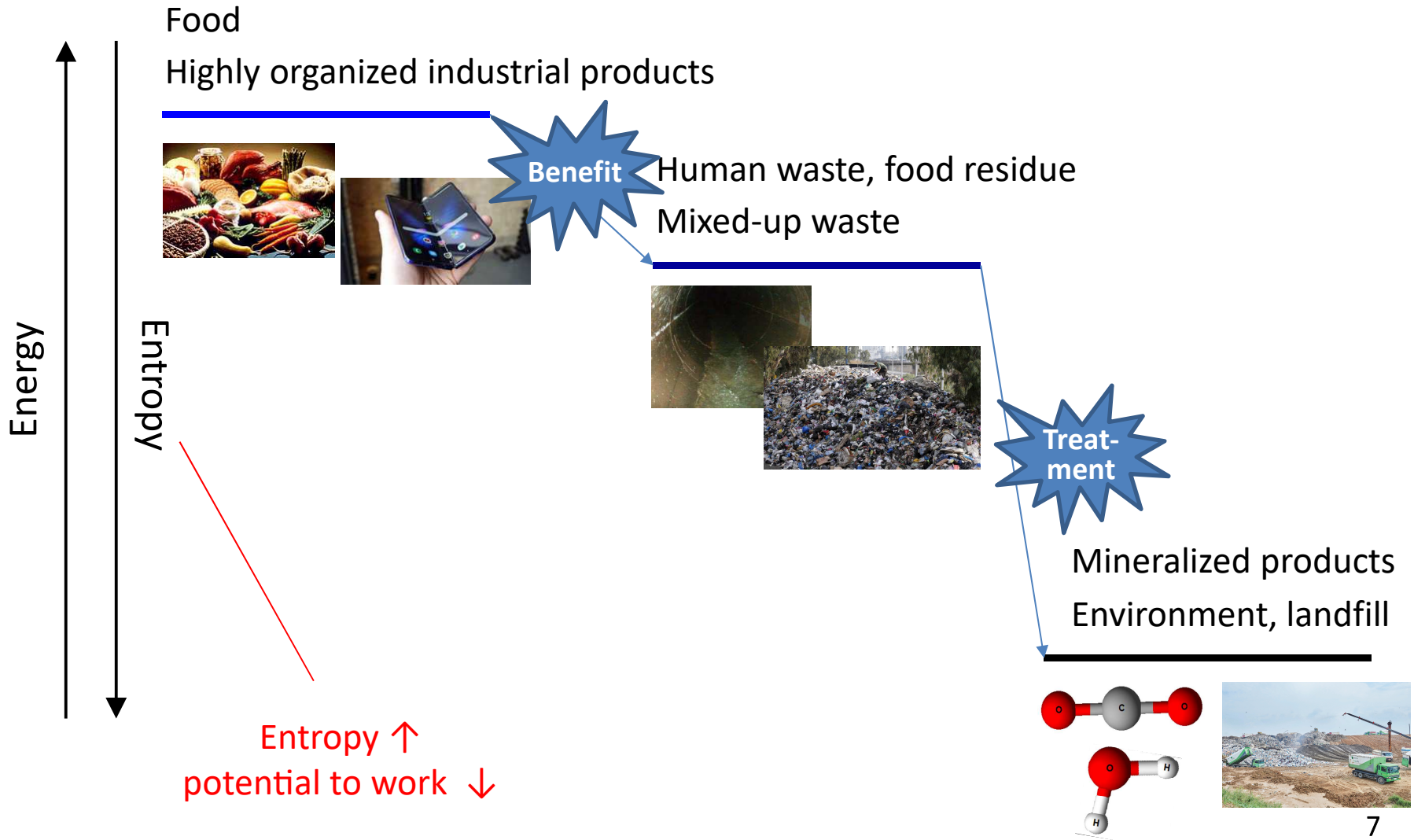

Current urban metabolism:

Wastewater drainage and treatment

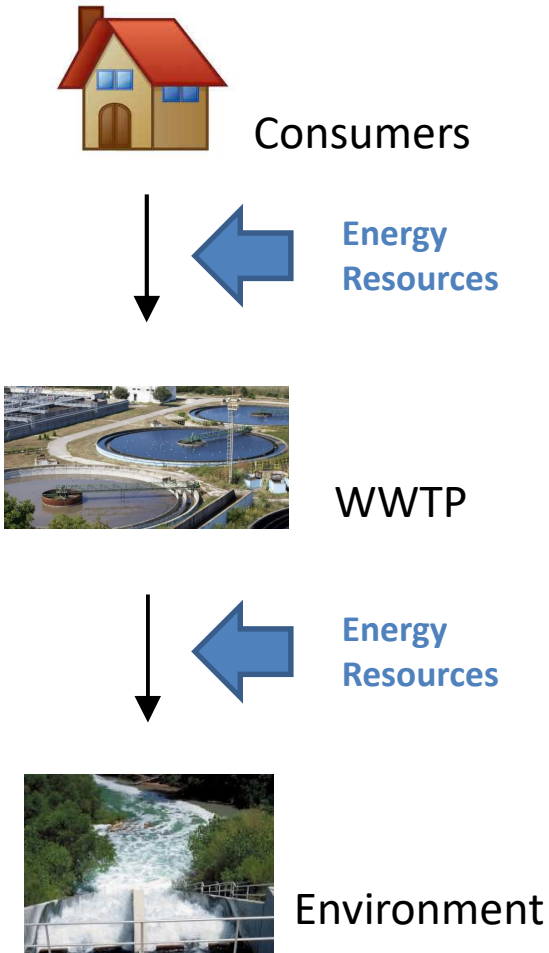

- **Drainage (transport)**
 - Pipeline & pumping
 - Spend energy & resources to lower elevation (?!)
 - ~70% of total cost for WW management
- **Treatment**
 - Key process: aerobic biodegradation
 - Spend energy & resources to mineralize organics (?!)
 - >50% of total E for WW treatment spent for aeration

Wastewater: a resource?

- Wastewater = water + nutrients + reduced carbon (chemical energy) + heat
- Wastewater reuse
 - Effective solution in dry regions
 - Reliable water resource
 - Usually cheaper than saltwater desalination
 - Non-potable water reuse
 - (Direct/Indirect) Potable water reuse
- Heat recovery from wastewater

Resource recovery from wastewater

Table 1. Energy Characteristics of a Typical Domestic Wastewater

constituent	typical concentrations ^a (mg/L)	energy (kWh/m ³)		
		maximum potential from organic oxidation ^b	required to produce fertilizing elements ^c	thermal heat available for heat-pump extraction ^d
organics (COD)				
total	500			
refractory	180			
suspended	80	0.31		
dissolved	100	0.39		
biodegradable	320			
suspended	175	0.67		
dissolved	145	0.56		
nitrogen				
organic	15		0.29	
ammonia	25		0.48	
phosphorus	8		0.02	
water				7.0
totals		1.93	0.79	7.0

^a After Tchobanoglous and Burton.⁴² ^b Based upon a theoretical 3.86 kWh energy production/kg COD oxidized to CO₂ and H₂O.³ ^c Based upon production energy of 19.3 kWh/kg N by Haber-Bosch Process and 2.11 kWh/kg P after Gellings and Parmenter.⁶ ^d Energy associated with a 6 °C change in water temperature through heat extraction.

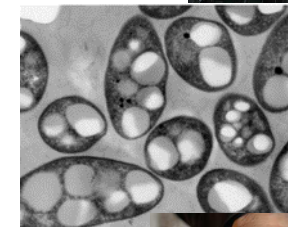

- Recovery of reduced carbon: CH₄, bioethanol, bio-oil, bioplastics, ...
- Recovery of other forms of energy: electricity, H₂, ...
- Recovery of nutrients: fertilizer (ex: struvite), soil amendments (ex: stabilized sludge), ...
- Recovery of low-temperature heat using heat pumps



Fresh urine, ~8800 mg N/L



x100 dilution

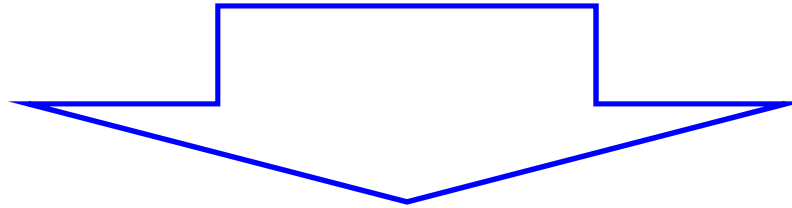

WWTP influent, 40~70 mg N/L



Source separation requires decentralization



VS



Fully centralized vs. fully decentralized

Fully centralized

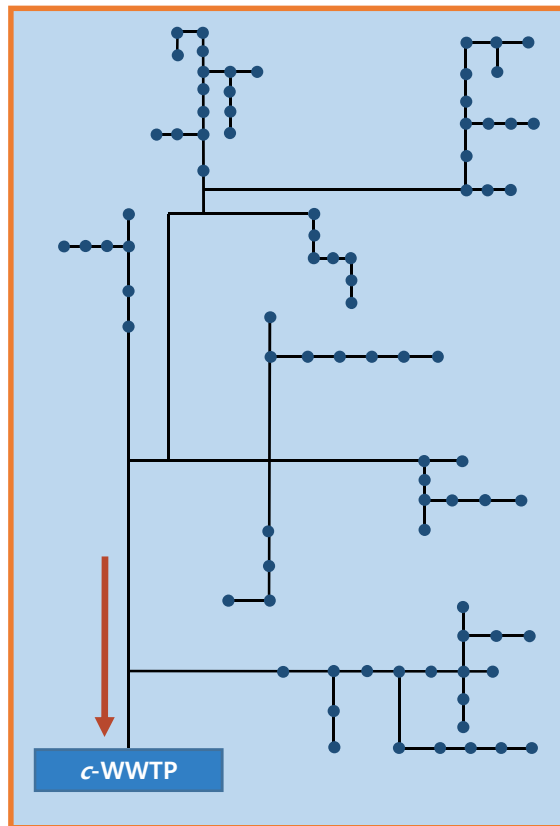

Fully decentralized

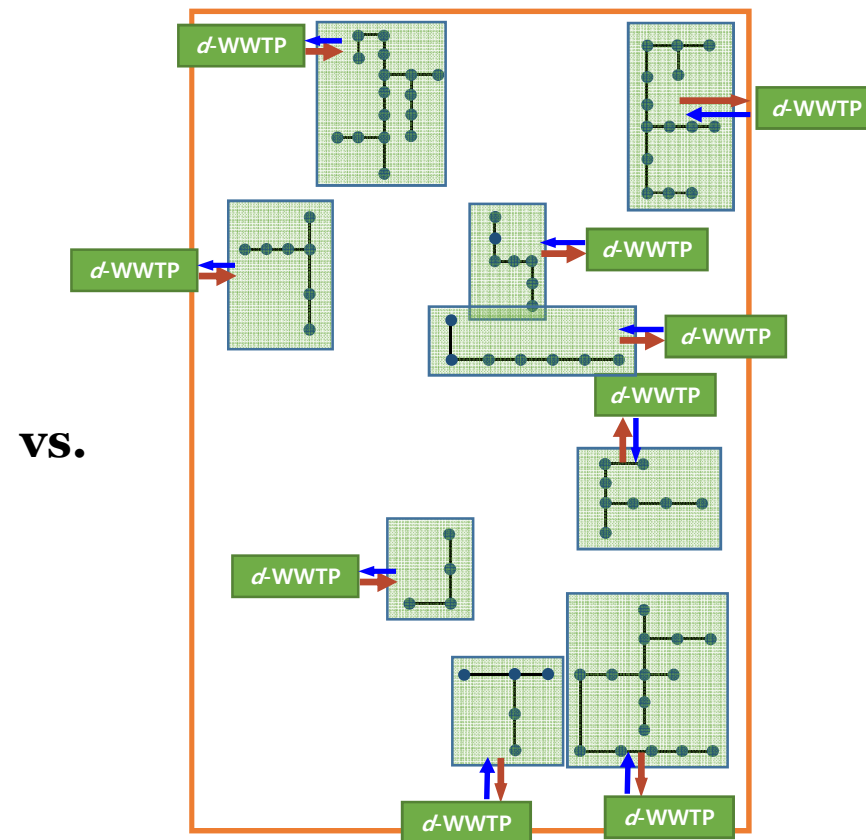

Fully centralized system

그림 10-7. 물재생센터별 처리구역 2012
Figure 10-7. Area of Sewage Treatment Center Service, 2012

-  물재생센터 Sewage Treatment Center
-  서남처리구역 Seonam Sewerage
-  탄천처리구역 Tancheng Sewerage
-  난지처리구역 Nanji Sewerage
-  중랑처리구역 Jungnang Sewerage

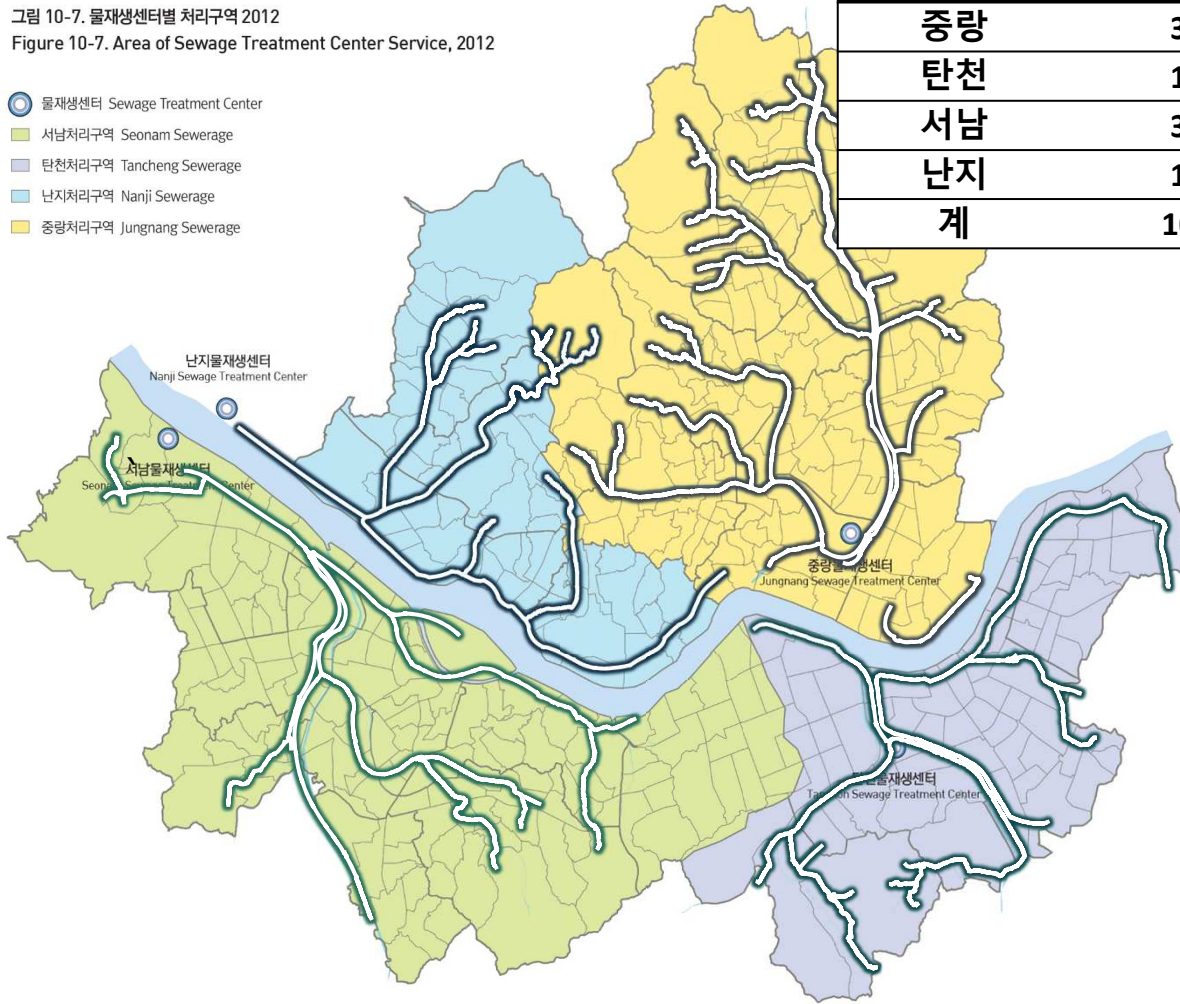

처리구역	관로연장(km)	처리시설용량(백만 m ³ /일)
중랑	3,601	1.71
탄천	1,896	1.10
서남	3,366	2.00
난지	1,839	1.00
계	10,728	5.81

Fully decentralized system



- New Monte Rosa, the Switzerland; at the top of Monte Rosa ski resort
- Project by ETH Zurich

- Designed as an energy-independent building
- Electricity consumption for wastewater treatment ↑ than designed by increased number of visitors
- At peak season, wastewater was drained untreated / transported outside by helicopters

Decentralization: issues

- Challenge of acceptance
- Challenge of transport
- Challenge of developing treatment processes

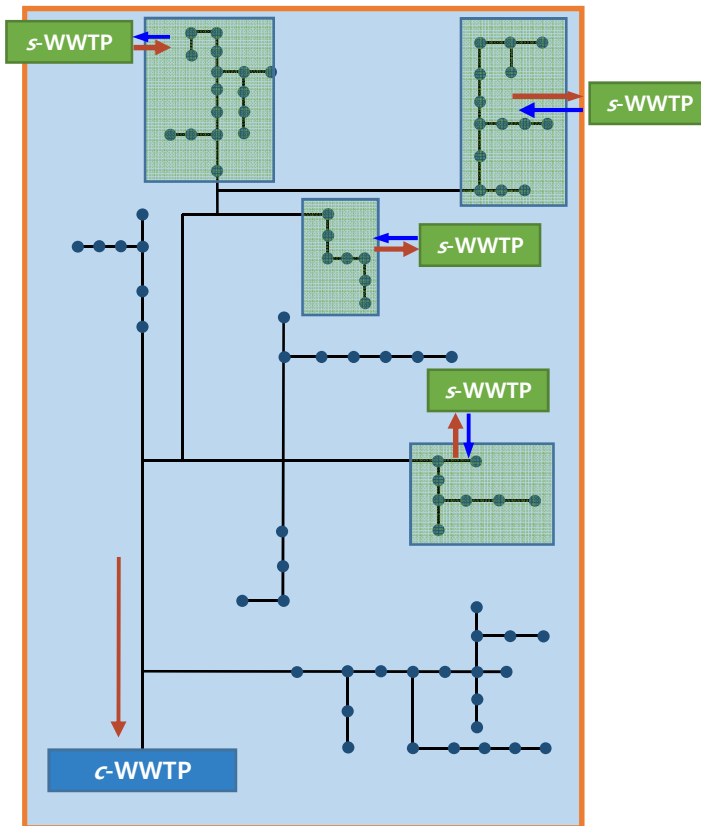

Table 10.1 Characteristic differences between decentralized and centralized wastewater treatment systems (see also Olsson 2013).

Topic	Properties of decentralized systems	Properties of centralized systems
Waste flow and load	Highly variable, subject to individual events	Variable, but individual events not apparent
Rainwater	Hardly an effect	May define hydraulic design load
Waste composition	Rather homogenous conditions between plants Rather concentrated waste	Different for each plant, subject to individual industries. Rather dilute wastewater.
Frequency of attendance	Irregular, long intervals	Daily to permanent
Cost of intervention	Large	Relatively low
Relative cost of sensors	High	Rather low
Calibration of sensors	Very low frequency and relatively very costly	Costly, but rather frequent
Sensor properties	Must be rugged and reliable, accuracy is of secondary importance, very infrequent maintenance	Must be sensitive, accurate and reliable but may require frequent maintenance
Data transmittance and control system	Due to on-going expansion of the number of systems, elements must be based on an adaptive grid	Typically fixed for one technological cycle
Control software	Highly standardized, but due to application in large numbers also highly optimized	May rely on modular design but adaptation to a specific plant typically required
Required process standardization	Very high, only standardized equipment can be produced in large numbers	Individual plants are typically designed as prototypes
Transport of pollutants and residues	Local extraction of concentrated residues and separate transport	Transported in sewers and extracted in the form of concentrated sludge
Handling of residues	May be centralized. An intermediate form may be transported to a central handling station	Typically occurs at the plant. Only small plants connect to larger ones

Need for optimization, flexibility

Hybrid
(cent.+satellite)



Clustered
(clustering for control, recovery, etc.)

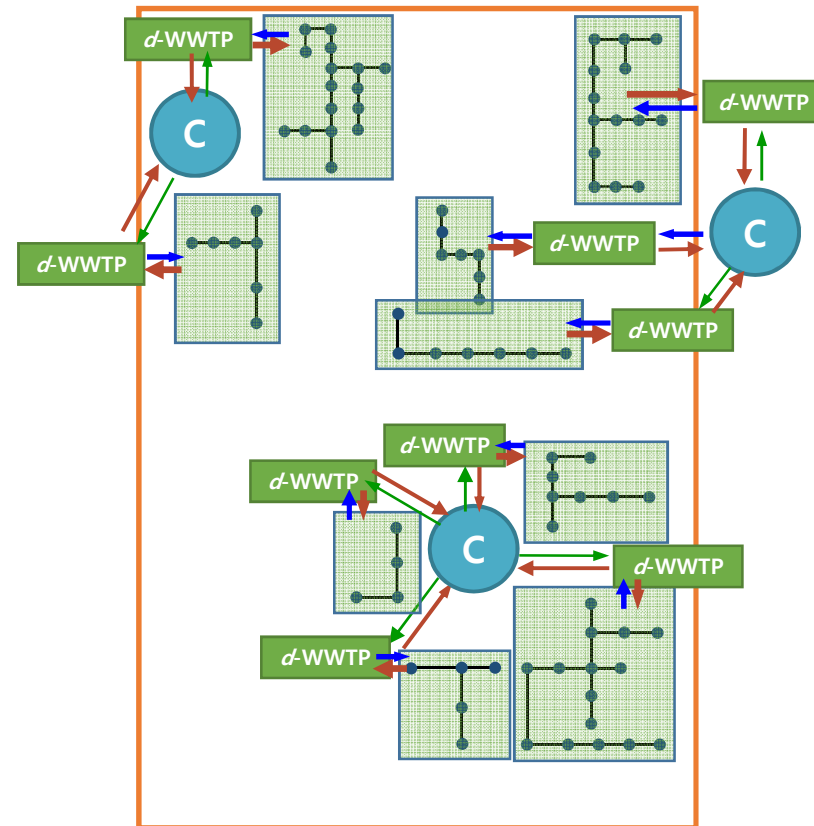

Potential starting point: sewer mining

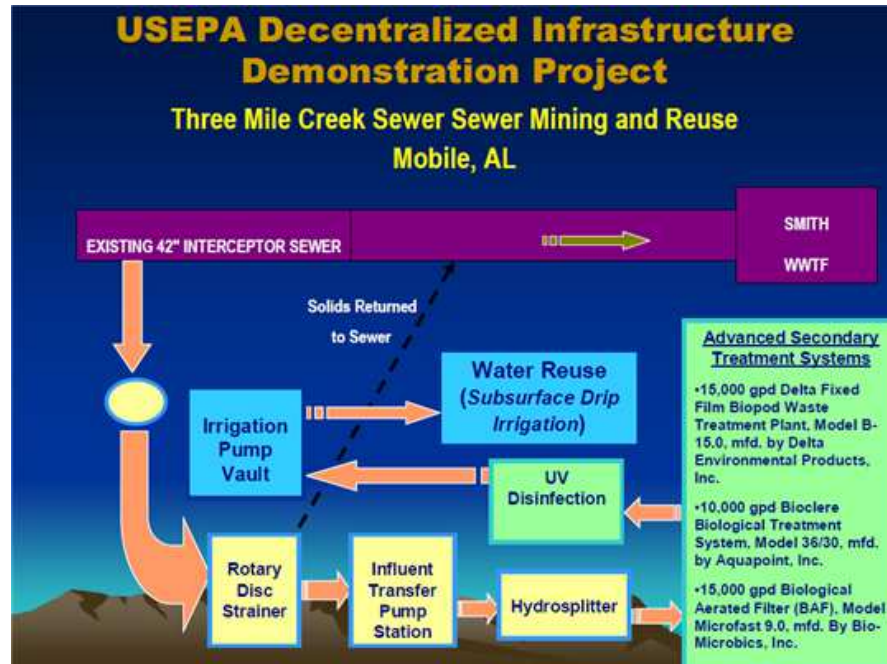

- City of Mobile, Alabama, US
- A portion of wastewater was extracted from a sewer pipe, treated at a decentralized facility & reused as irrigation water for parks

- Water extraction rate: 150 m³/day
- Decentralized process: rotary screen (pretreatment) → biological treatment (attached growth) → UV disinfection → subsurface irrigation
- Irrigation water quality: BOD ~10 mg/L, T-P 5~15 mg/L, NO₃-N 4~14 mg N/L

Towards ideality: self-organization?

- “A process where some form of overall order arises from local interactions between parts of an initially disordered system”

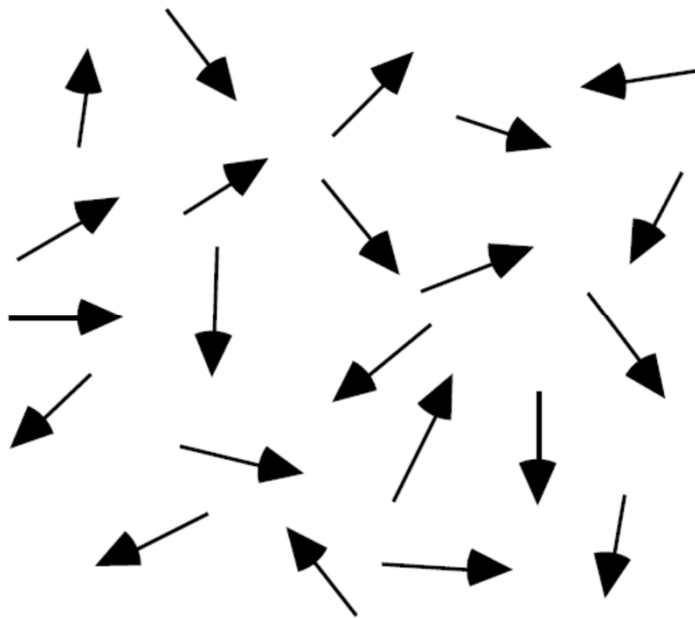

Disordered arrangement of “spins”

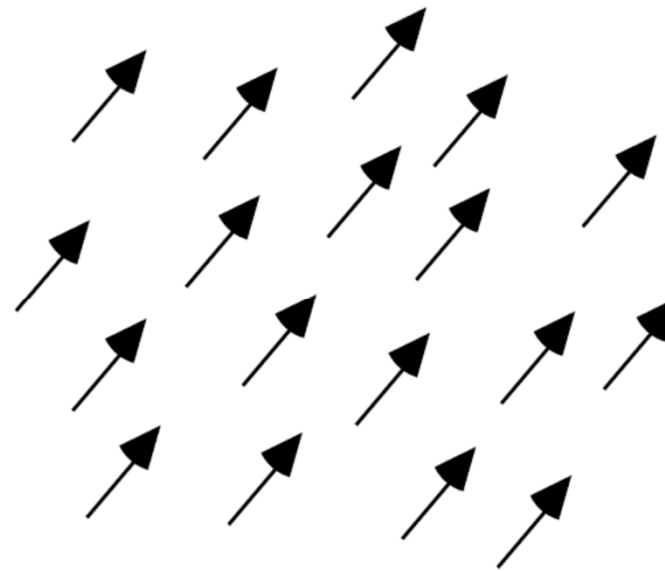

Ordered arrangement of “spins”: magnet

Self-organization

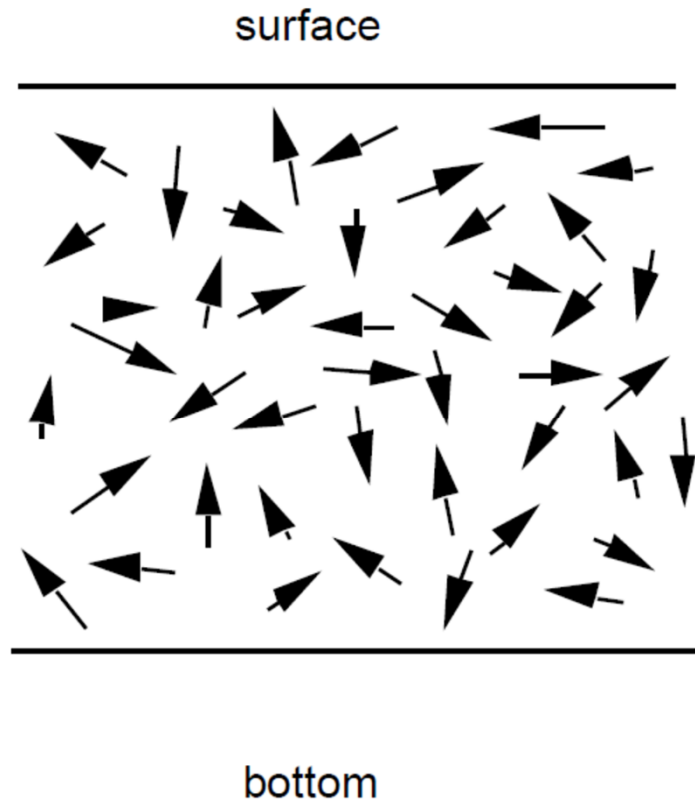

Random movement of water molecules

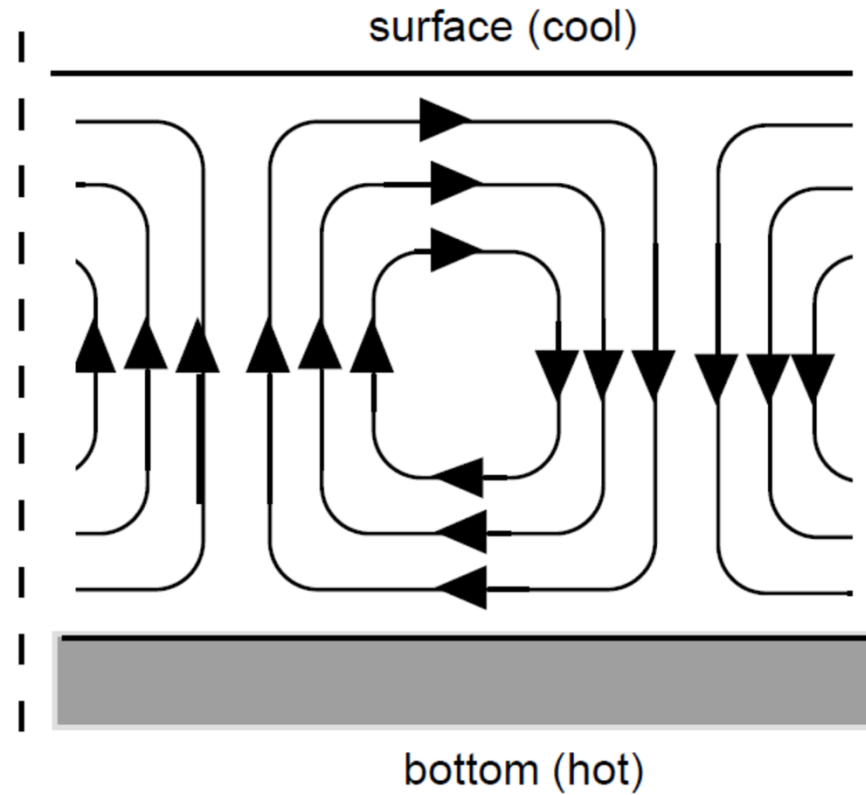

Ordered movement of water molecules:
"Bénard roll"

Characteristics of self-organizing systems

- Global order from local interactions
- Distributed control
- Robustness, resilience
- Non-linearity and feedback
- Emergence
- Bifurcation
- Far-from-equilibrium dynamics



Heylighen, F. (2001) The science of self-organization and adaptivity. The Encyclopedia of Life Support Systems. 5(3): 253-280.

Self-organization in urban infrastructure?

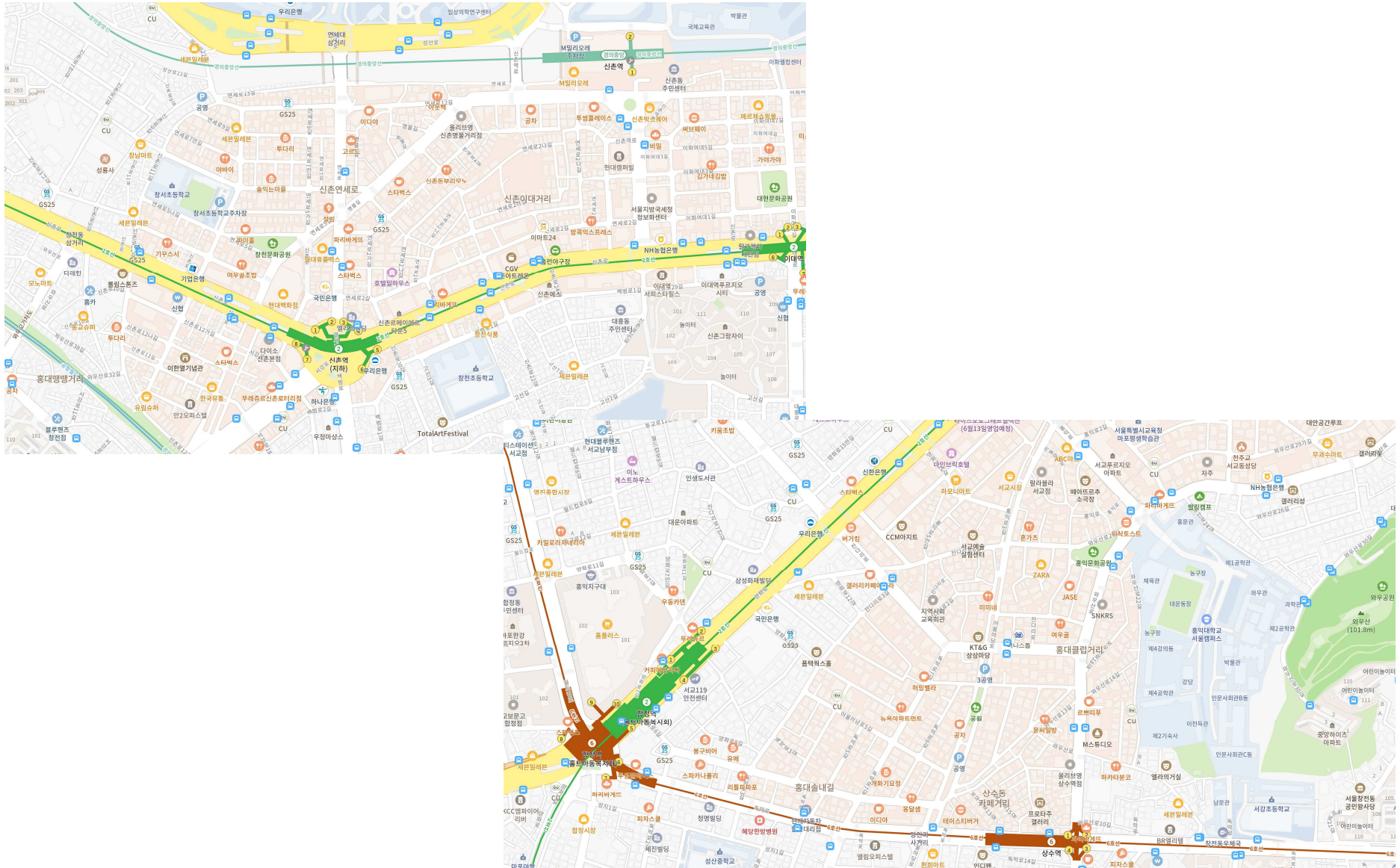

For the new paradigm

- Think differently but comprehensively: a “smartphone approach”

“A smart phone is not a downsized telephone, TV, photo camera, computer, CD player, and so on but a new device which fulfills its tasks on the basis of entirely new technology and with considerably less material and at less cost than all these gadgets together.”

