

# Gas Breakdown and Plasma Sources

**Fall, 2022**

**Kyoung-Jae Chung**

***Department of Nuclear Engineering***

**Seoul National University**

# Various plasma sources

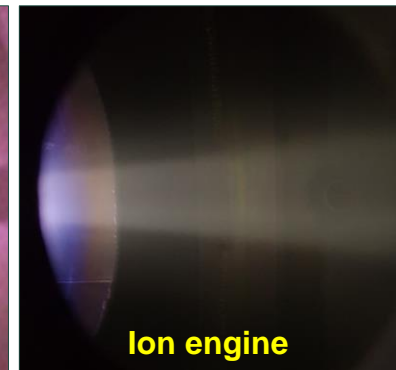
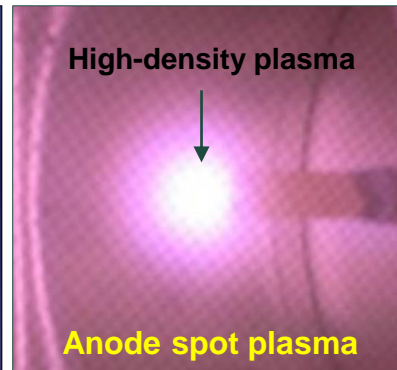
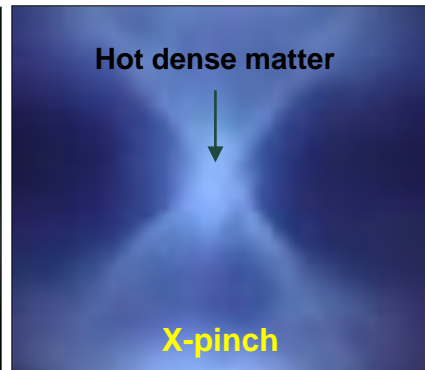
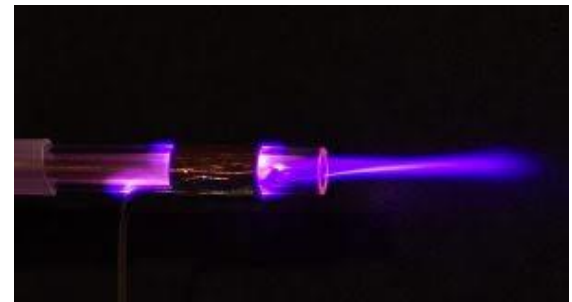
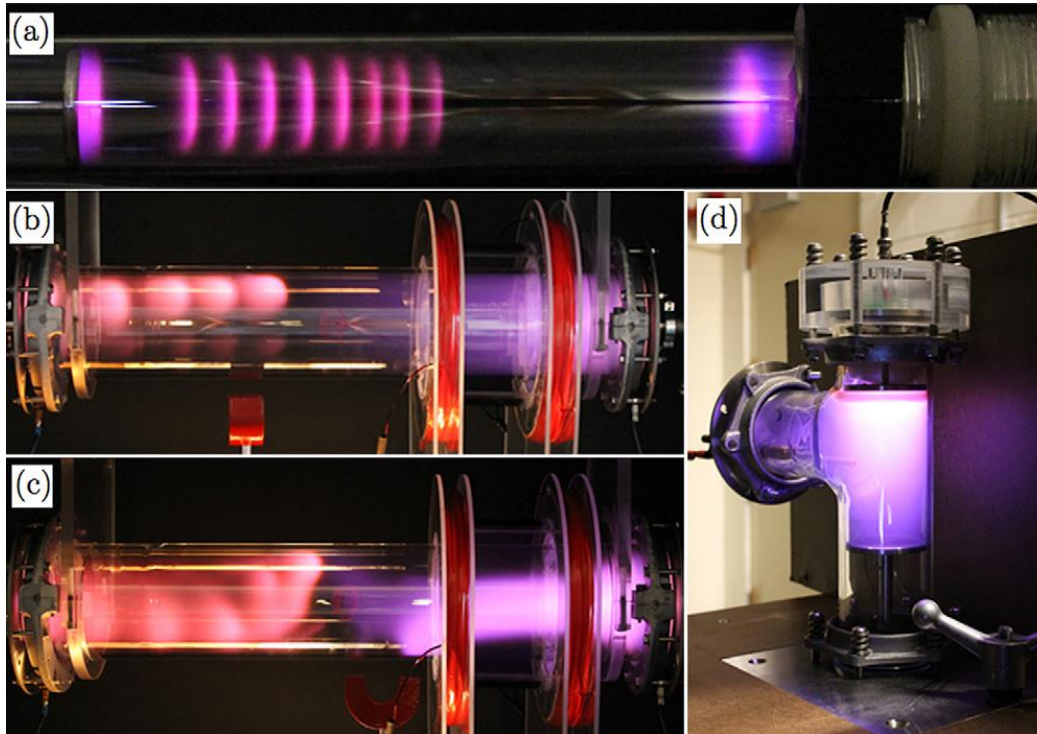

# Gas breakdown: Paschen's curves for breakdown voltages in various gases

- Friedrich Paschen discovered empirically in 1889.

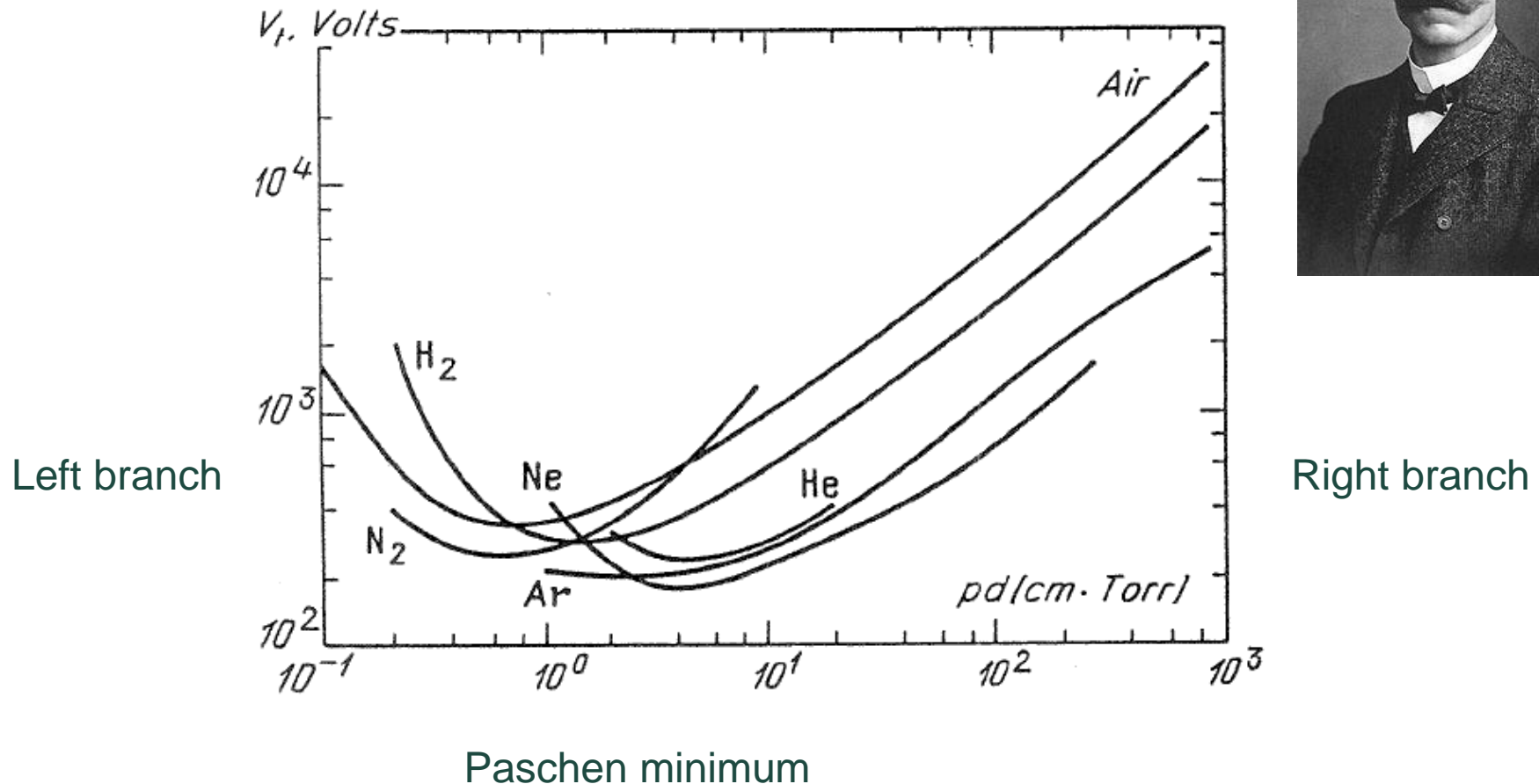

F. Paschen, Wied. Ann. 37, 69 (1889)

# Generation of charged particles: electron impact ionization

- Plasma sources are classified by the **electron heating method**.

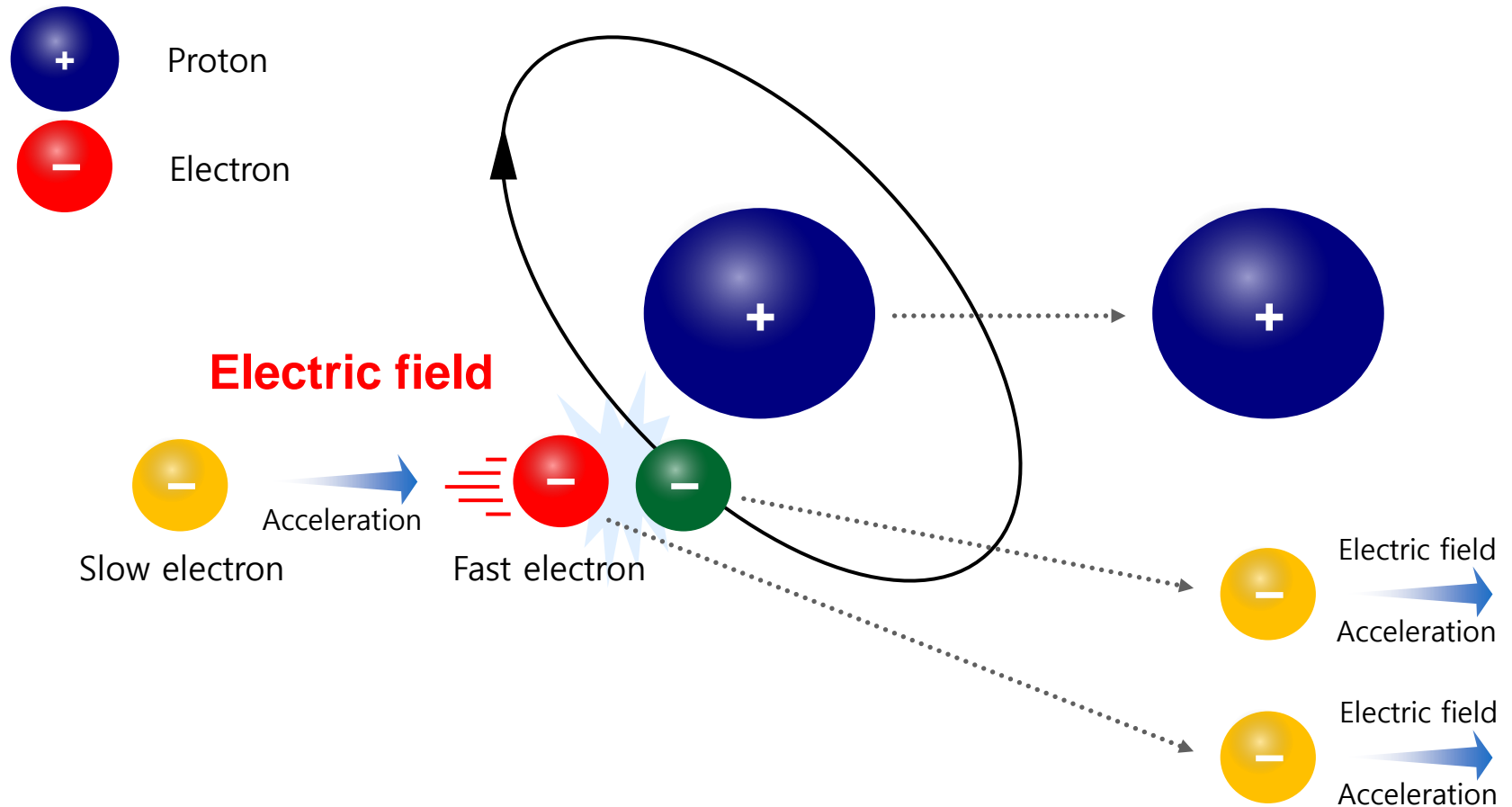

Ionization energy of hydrogen: 13.6 eV

# Townsend mechanism: electron avalanche

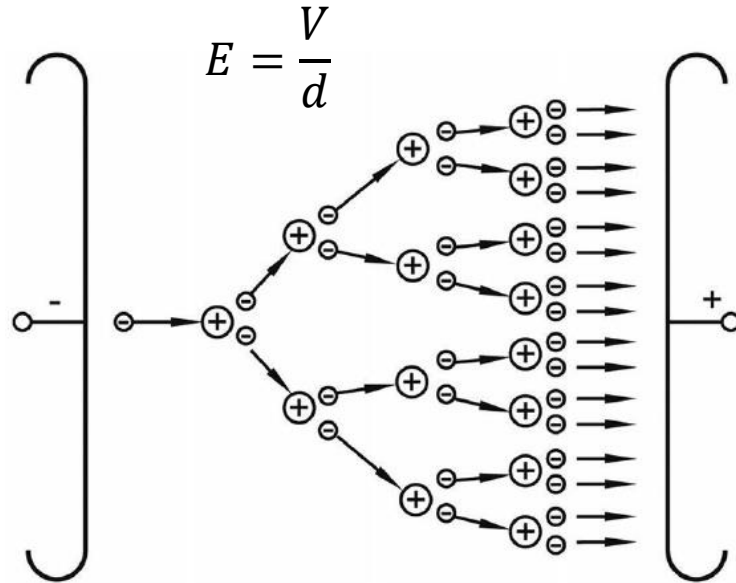

- Townsend ionization coefficient ( $\alpha$ ) : electron multiplication

: production of electrons per unit length along the electric field  
(ionization event per unit length)

$$\frac{dn_e}{dx} = \alpha n_e$$

$$n_e = n_{e0} \exp(\alpha x)$$

$$M = \frac{n_e}{n_{e0}} = e^{\alpha x}$$

# Townsend 1<sup>st</sup> ionization coefficient

- When an electron travels a distance equal to its free path  $\lambda_e$  in the direction of the field  $E$ , it gains an energy of  $eE\lambda_e$ . For the electron to ionize, its gain in energy should be at least equal to the ionization potential  $V_i$  of the gas:

$$e\lambda_e E \geq eV_i \qquad \lambda_e = \frac{1}{n\sigma} \propto \frac{1}{p}$$

- The Townsend 1<sup>st</sup> ionization coefficient is equal to the number of free paths ( $= 1/\lambda_e$ ) times the probability of a free path being more than the ionizing length  $\lambda_{ie}$ ,

$$\alpha \propto \frac{1}{\lambda_e} \exp\left(-\frac{\lambda_{ie}}{\lambda_e}\right) \propto \frac{1}{\lambda_e} \exp\left(-\frac{V_i}{\lambda_e E}\right)$$

$$\alpha/p = A \exp\left(-\frac{B}{E/p}\right)$$

- A and B must be experimentally determined for different gases.

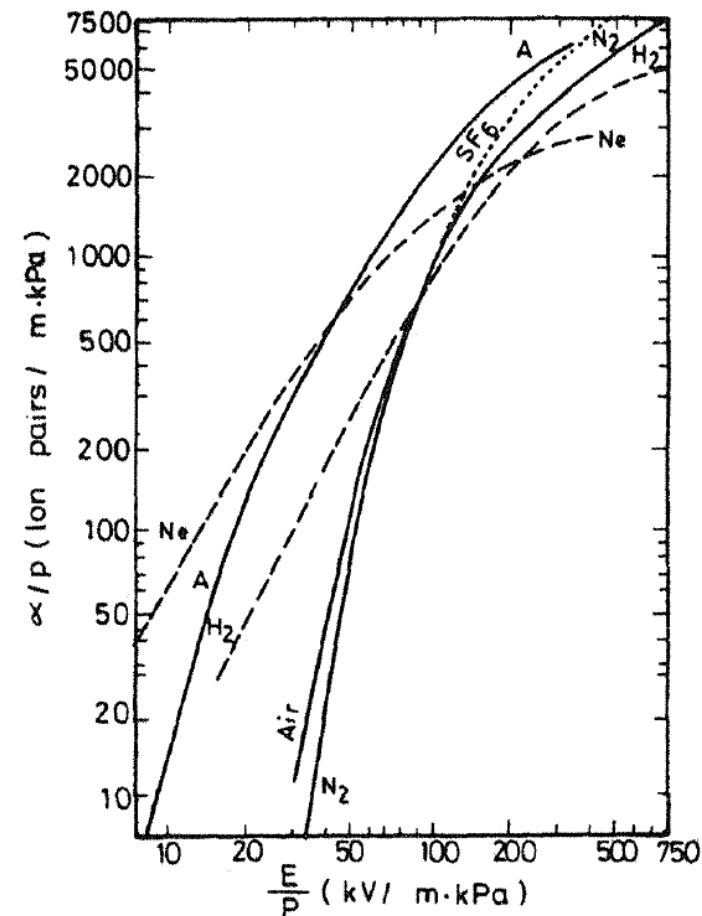

# Townsend's avalanche process is not self-sustaining

Ionization-free region (recombination region + saturation region)

Townsend first ionization region ( $\alpha$  process)

Townsend second ionization region ( $\gamma$  process)

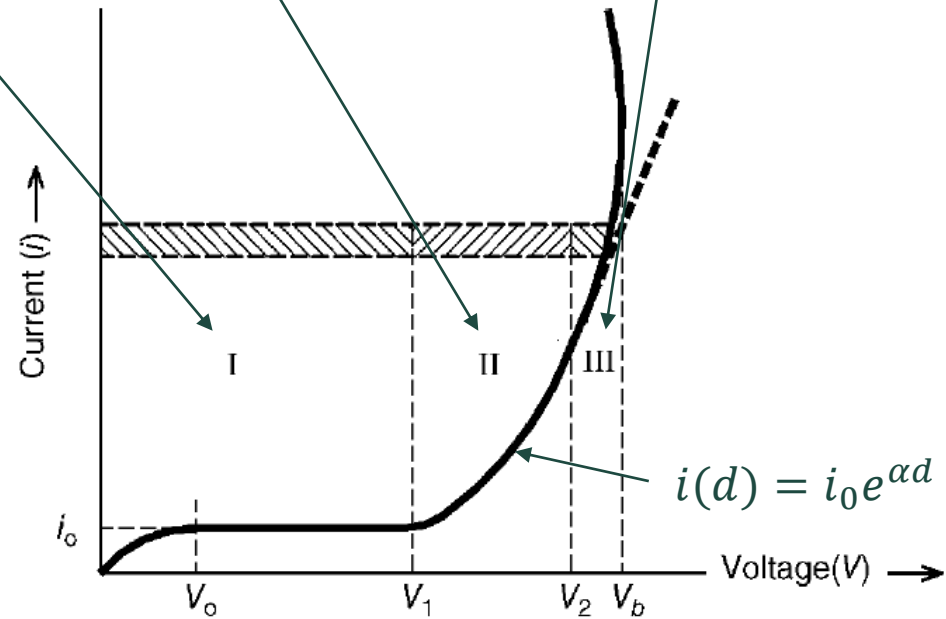
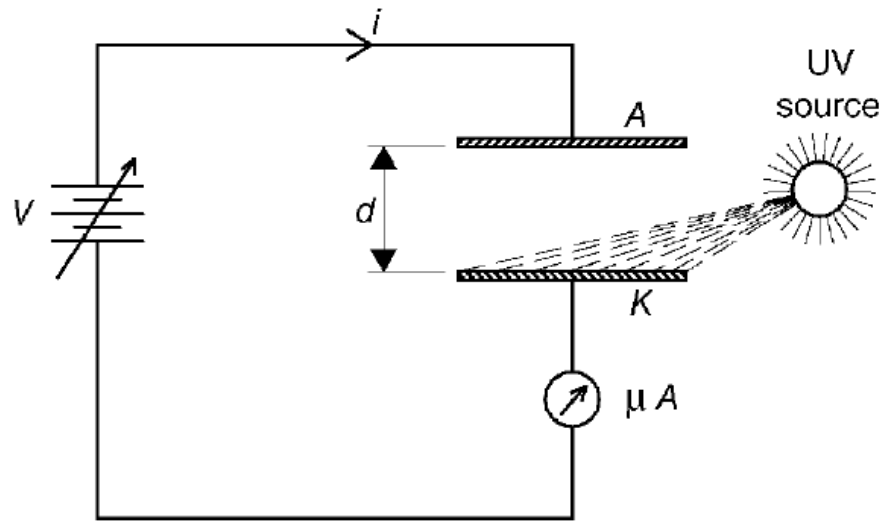

- Secondary electron emission by ion impact: when heavy positive ions strike the cathode wall, secondary electrons are released from the cathode material.

# Townsend's criterion for breakdown

- Townsend's avalanche process cannot be sustained without external sources for generating seed electrons.
- The self-sustaining condition is given by

$$M = \frac{e^{\alpha d}}{1 - \gamma(e^{\alpha d} - 1)} \rightarrow \infty$$

$$\alpha d = \ln \left( 1 + \frac{1}{\gamma} \right)$$

↑  
Secondary electron emission coefficient

- Paschen's law

$$\alpha/p = A \exp \left( -\frac{B}{E/p} \right) \quad + \quad \alpha d = \ln \left( 1 + \frac{1}{\gamma} \right)$$

$$\alpha d = A p d \exp \left( -\frac{B}{E/p} \right) = A p d \exp \left( -\frac{B p d}{V_B} \right) = \ln \left( 1 + \frac{1}{\gamma} \right)$$

$$V_B = \frac{B p d}{\ln[A p d / \ln(1 + 1/\gamma)]} = f(p d)$$



# Paschen curve

- Minimum breakdown voltage

$$V_{B,min} = \frac{eB}{A} \ln \left( 1 + \frac{1}{\gamma} \right)$$

at  $(pd)_{min} = \frac{e}{A} \ln \left( 1 + \frac{1}{\gamma} \right)$

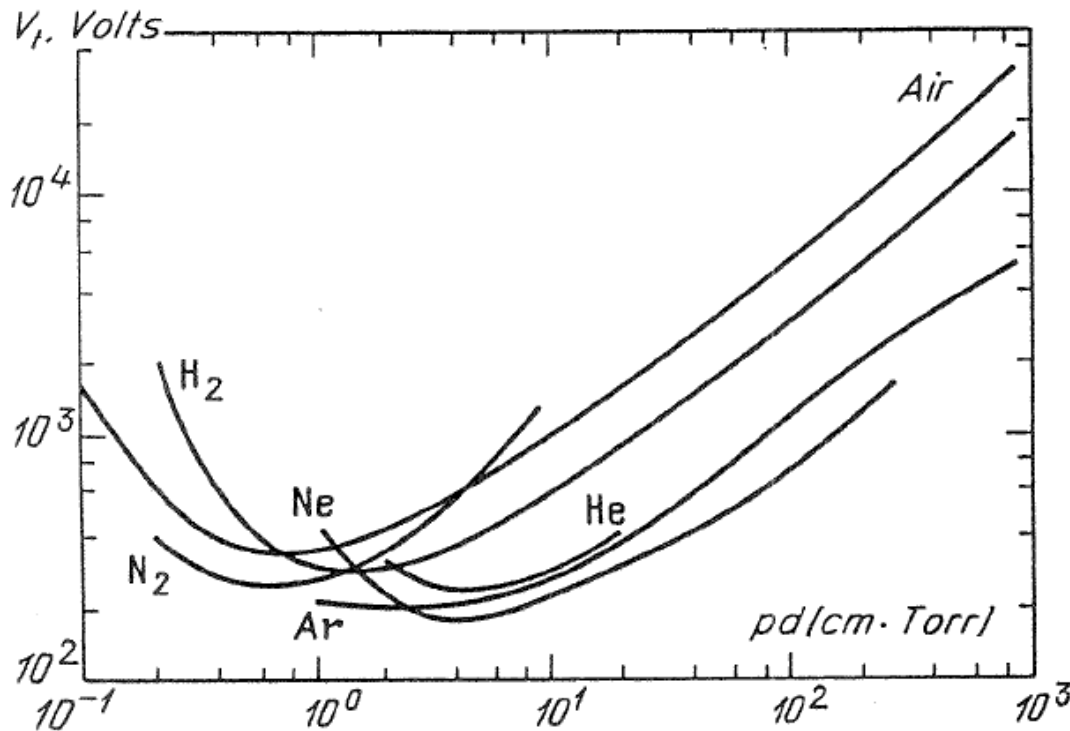

Gas	$V_{s,min}$ (V)	$(pd)_{min}$ (torr-cm)
Air (dry)	327	0.567
A	137	0.9
H <sub>2</sub>	273	1.15
He	156	4.0
CO <sub>2</sub>	420	0.51
N <sub>2</sub>	251	0.67
O <sub>2</sub>	450	0.7

- Main factors:
  - Pressure
  - Voltage
  - Electrode distance
  - Gas species
  - Electrode material (SEE)
- Small  $pd$ : too small collision
- Large  $pd$ : too often collision

# Summary of Townsend gas breakdown theory

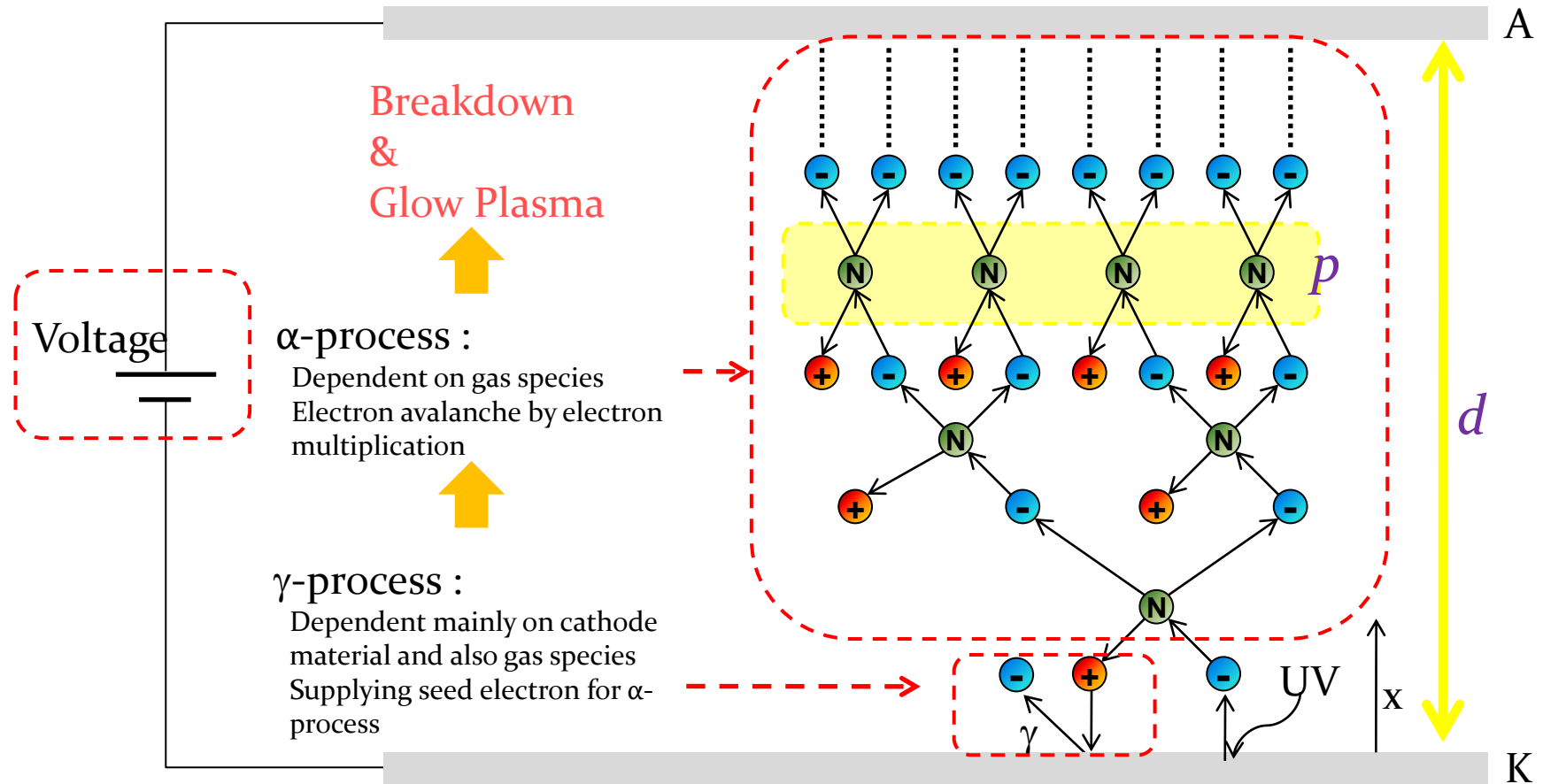

- Two processes ( $\alpha$  and  $\gamma$ ) are required to sustain the discharge.
- Q. Why are electronegative gases (e.g.  $\text{SF}_6$ ) widely used for gas insulation?

# Typical current-voltage characteristics for electrical discharge of gases

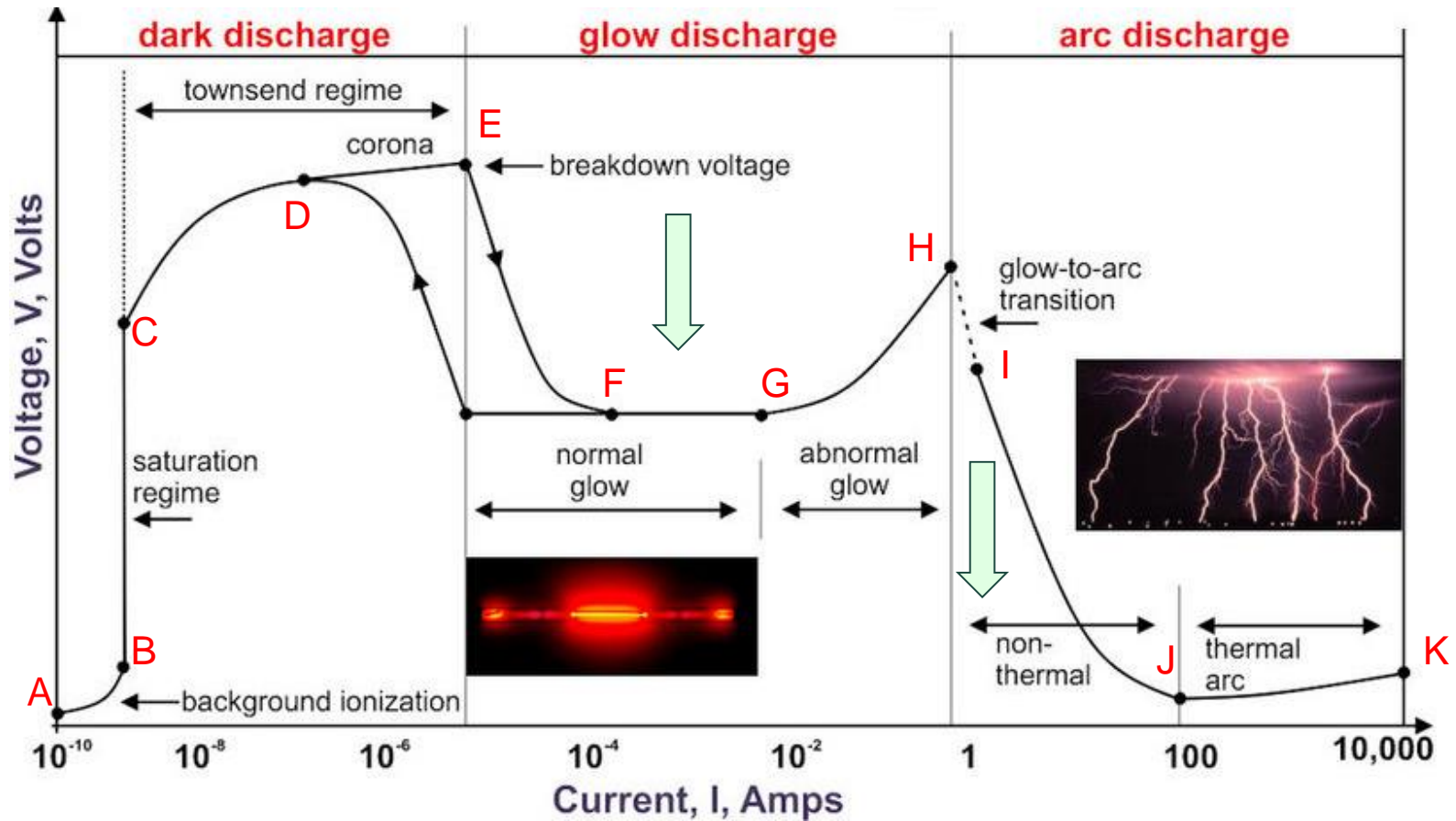

# Electrical discharge regime

## ● Dark discharge

- **A – B** During the background ionization stage of the process the electric field applied along the axis of the discharge tube sweeps out the ions and electrons created by ionization from background radiation. Background radiation from cosmic rays, radioactive minerals, or other sources, produces a constant and measurable degree of ionization in air at atmospheric pressure. The ions and electrons migrate to the electrodes in the applied electric field producing a weak electric current. Increasing voltage sweeps out an increasing fraction of these ions and electrons.
- **B – C** If the voltage between the electrodes is increased far enough, eventually all the available electrons and ions are swept away, and the current saturates. In the saturation region, the current remain constant while the voltage is increased. This current depends linearly on the radiation source strength, a regime useful in some radiation counters.
- **C – D** If the voltage across the low pressure discharge tube is increased beyond point C, the current will rise exponentially. The electric field is now high enough so the electrons initially present in the gas can acquire enough energy before reaching the anode to ionize a neutral atom. As the electric field becomes even stronger, the secondary electron may also ionize another neutral atom leading to an avalanche of electron and ion production. The region of exponentially increasing current is called the Townsend discharge.
- **D – E** Corona discharges occur in Townsend dark discharges in regions of high electric field near sharp points, edges, or wires in gases prior to electrical breakdown. If the coronal currents are high enough, corona discharges can be technically “glow discharges”, visible to the eye. For low currents, the entire corona is dark, as appropriate for the dark discharges. Related phenomena include the silent electrical discharge, an inaudible form of filamentary discharge, and the brush discharge, a luminous discharge in a non-uniform electric field where many corona discharges are active at the same time and form streamers through the gas.

# Electrical discharge regime

## ● Breakdown

- E Electrical breakdown occurs in Townsend regime with **the addition of secondary electrons emitted from the cathode due to ion or photon impact**. At the breakdown, or sparking potential  $V_B$ , the current might increase by a factor of  $10^4$  to  $10^8$ , and is usually limited only by the internal resistance of the power supply connected between the plates. If the internal resistance of the power supply is very high, the discharge tube cannot draw enough current to break down the gas, and the tube will remain in the corona regime with small corona points or brush discharges being evident on the electrodes. If the internal resistance of the power supply is relatively low, then the gas will break down at the voltage  $V_B$ , and move into the normal glow discharge regime. The breakdown voltage for a particular gas and electrode material depends on the product of the pressure and the distance between the electrodes,  $pd$ , as expressed in Paschen's law (1889).

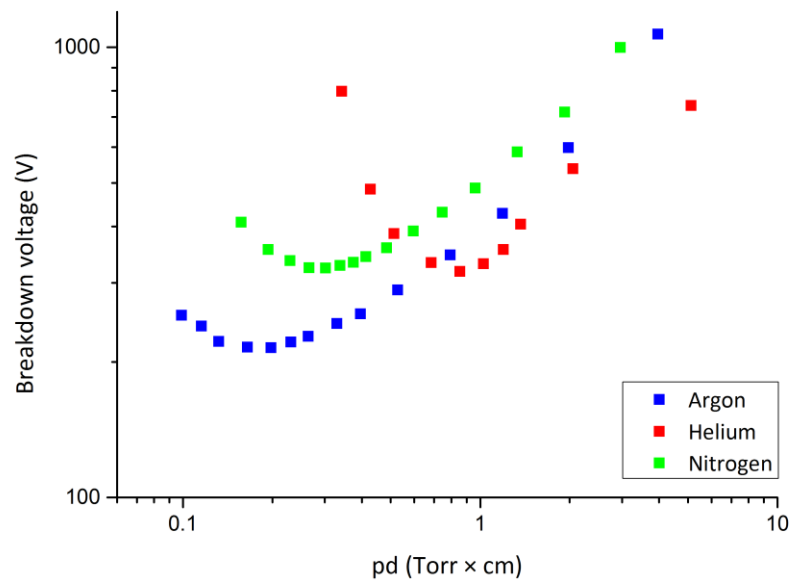

2015

# Electrical discharge regime

## ● Glow discharge

- **F – G** After a discontinuous transition from E to F, the gas enters the **normal glow** region, in which **the voltage is almost independent of the current** over several orders of magnitude in the discharge current. The electrode current density is independent of the total current in this regime. This means that the plasma is in contact with only a small part of the cathode surface at low currents. As the current is increased from F to G, the fraction of the cathode occupied by the plasma increases, until plasma covers the entire cathode surface at point G.
- **G – H** In the **abnormal glow** regime above point G, the voltage increases significantly with the increasing total current in order to force the cathode current density above its natural value and provide the desired current. Starting at point G and moving to the left, a form of hysteresis is observed in the voltage-current characteristic. The discharge maintains itself at considerably lower currents and current densities than at point F and only then makes a transition back to Townsend regime.

## ● Arc discharge

- **H – K** At point H, the electrodes become **sufficiently hot that the cathode emits electrons thermionically**. If the DC power supply has a sufficiently low internal resistance, the discharge will undergo a glow-to-arc transition, H-I. The arc regime, from I through K is one where the discharge voltage decreases as the current increases, until large currents are achieved at point J, and after that the voltage increases slowly as the current increases.

# Structure of glow discharge

2015

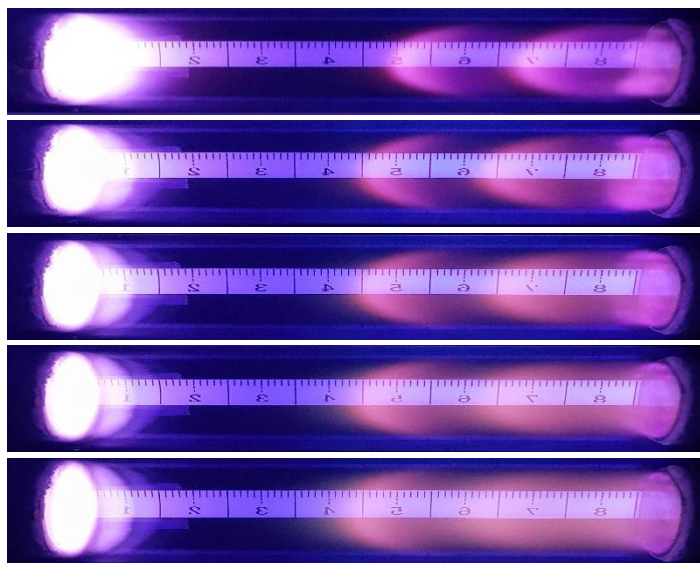
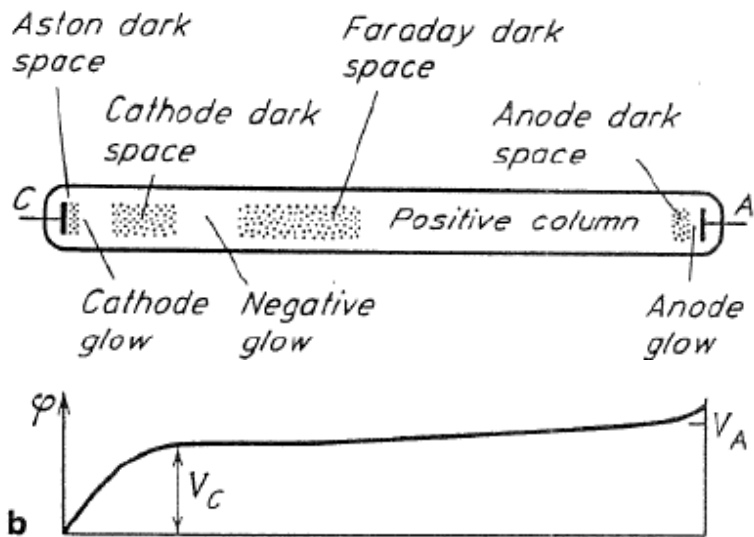

압력 증가

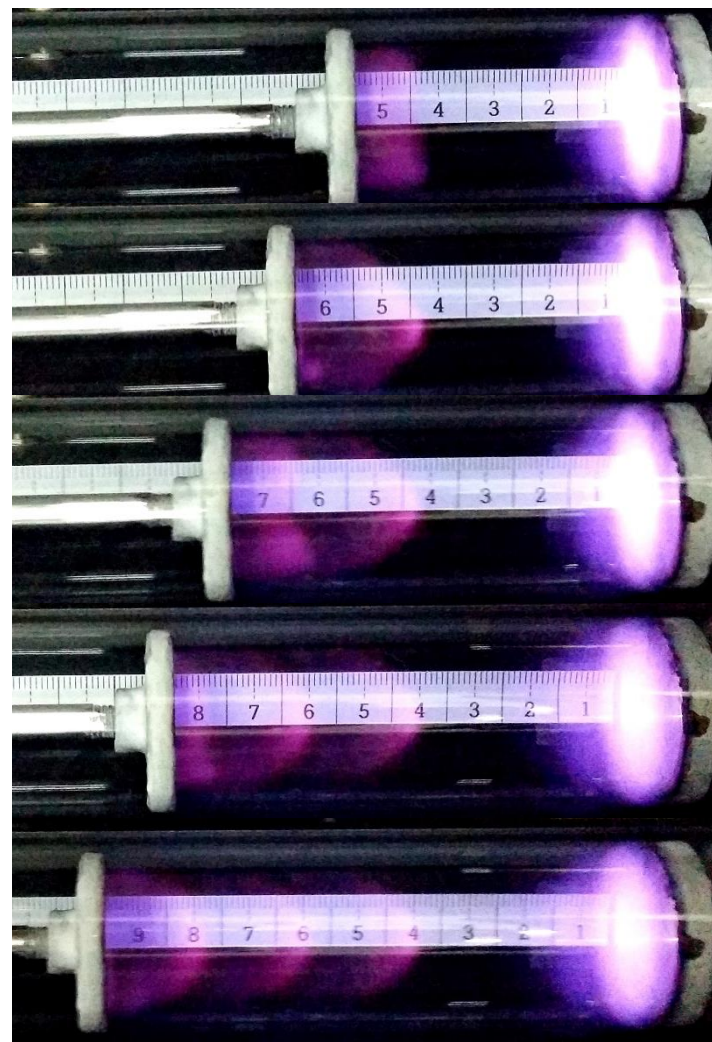

거리 증가

# Arc discharge

- Electrons emitted from the cathode spot can be produced mainly by **thermionic emission** if the cathode is made of a high-melting-point metal (e.g., carbon, tungsten, or molybdenum). With cathodes of low melting point, electrons can be supplied by **field emission** from points of micro-roughness where the electric field is highly concentrated.
- An additional important source of electrons at the cathode is ionized metal vapor.

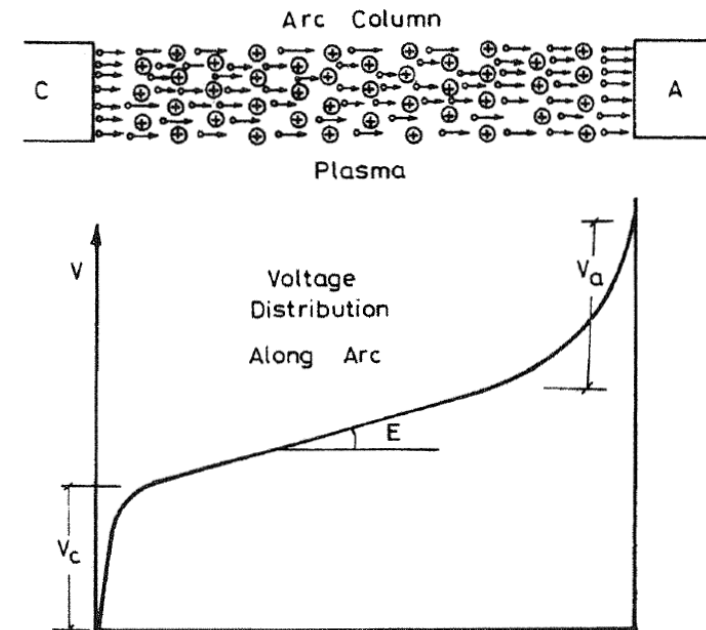
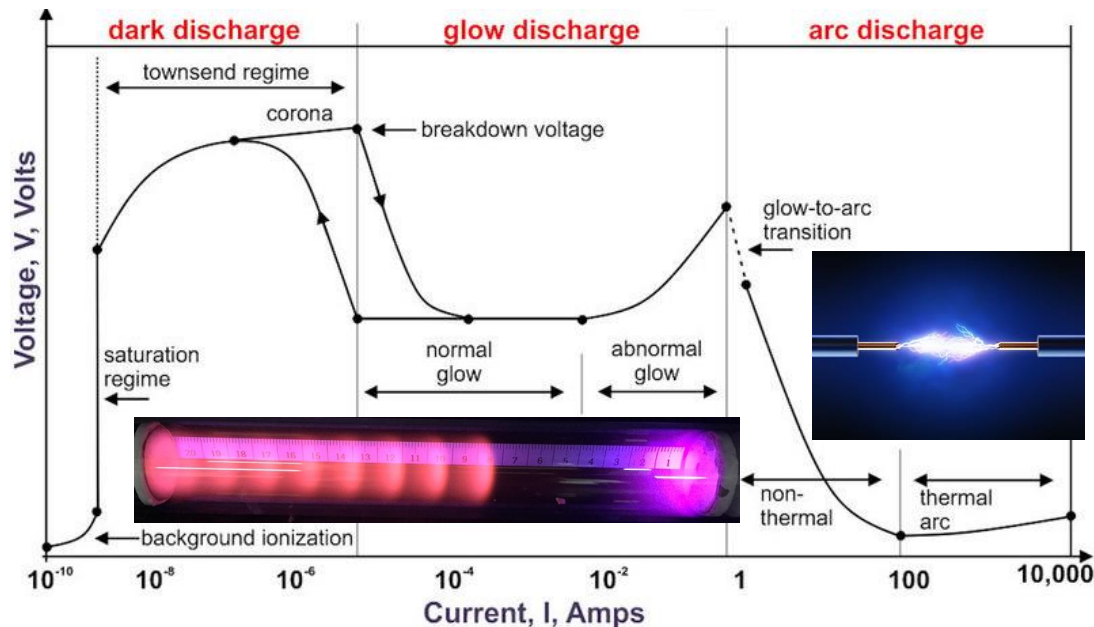



# Arc vs. glow

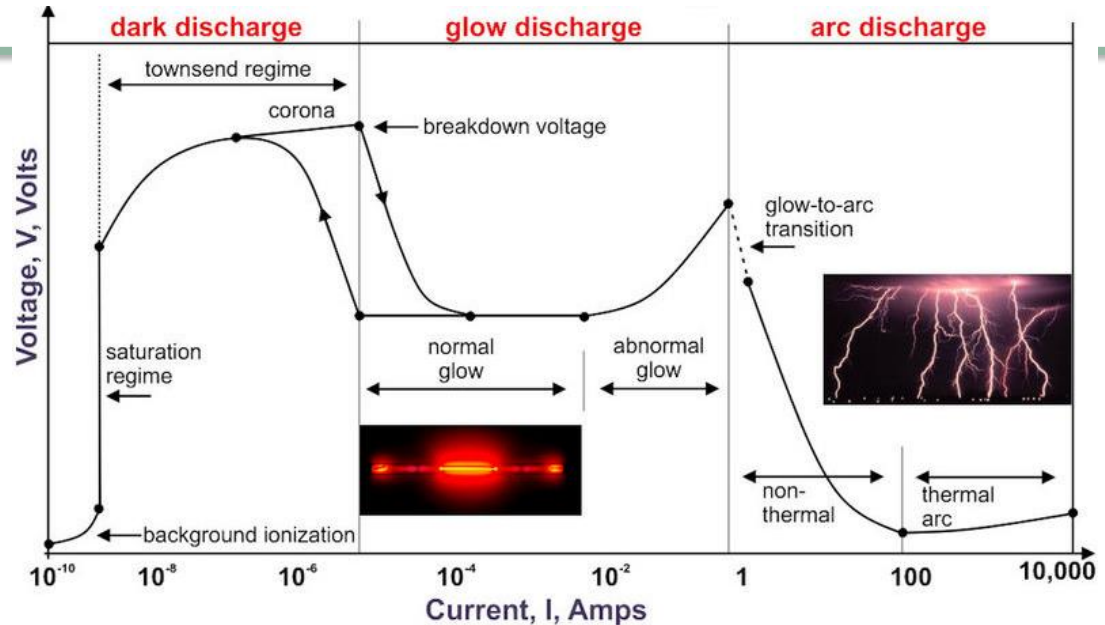

## ● Glow discharge

- 전극간 전압 : 수백 V
- 전류 : 수 mA
- 양이온이나 광자에 의한 음극에서의 이차전자 방출에 의하여 방전이 지속되며 기체 중에 전극물질의 증발성분을 포함시키지 않는다.

## ● Arc discharge

- 전극간 전압 : 수십 V
- 전류 : 수 A 이상
- 음극의 2차 기구로서 열전자 방출 및 전계 방출이 중요한 역할을 하고 증발한 전극 물질은 기체분자와 더불어 방전의 형성과 유지에 관계한다.

# Corona discharges

- Corona discharges appear in gases when electrodes have strong two-dimensional variations.
- Corona (crown in Latin) is a pattern of bright sparks near a pointed electrode. In such a region, the electric field is enhanced above the breakdown limit so that electron avalanches occur.

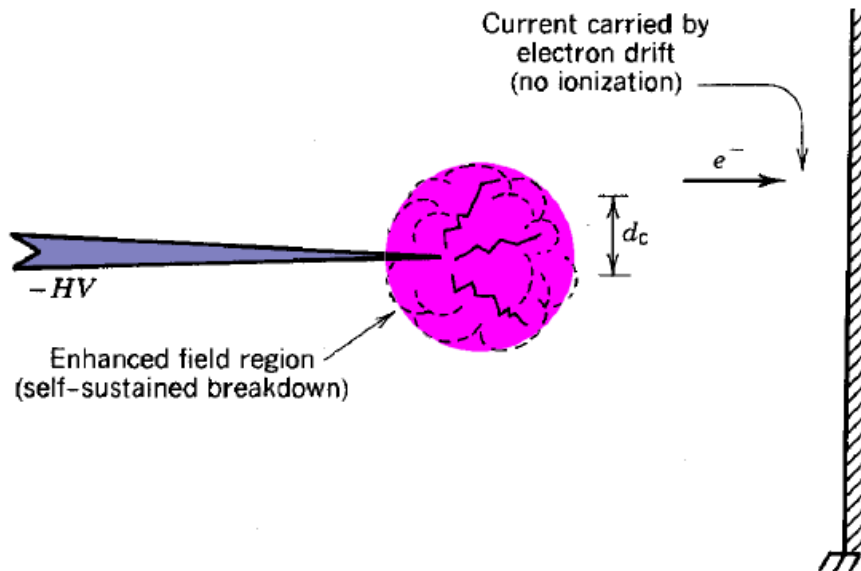

# Typical characteristic curve for gas discharges: self-sustaining or non-self-sustaining

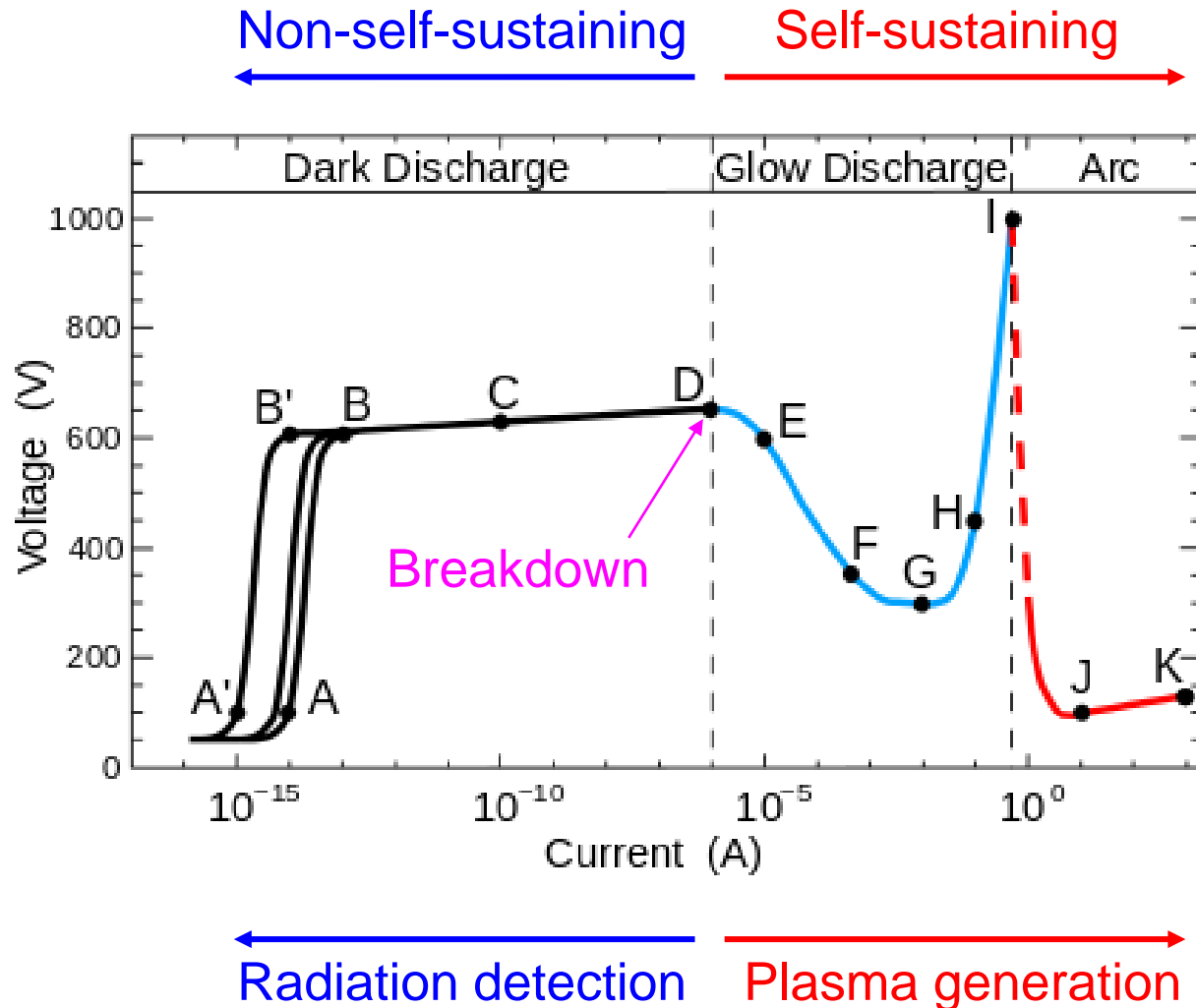

# RF (radio-frequency) discharge

- Oscillation of a charged particle in an electric field at different frequencies

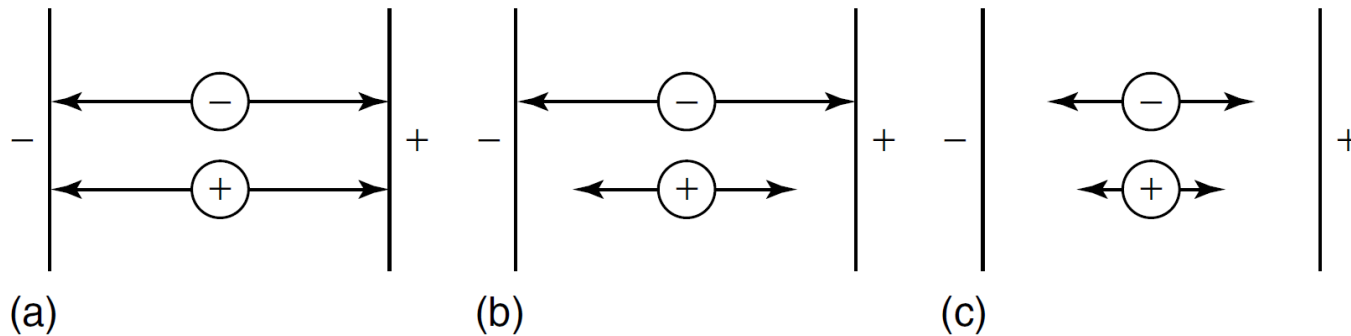

- DC
- period of supply longer than the time for the ion to traverse the path length, but shorter than for an electron
- period of supply shorter than for the electron or ion to traverse the path length

# Classification of plasma discharge

- Plasma sources are classified by the electron heating method.

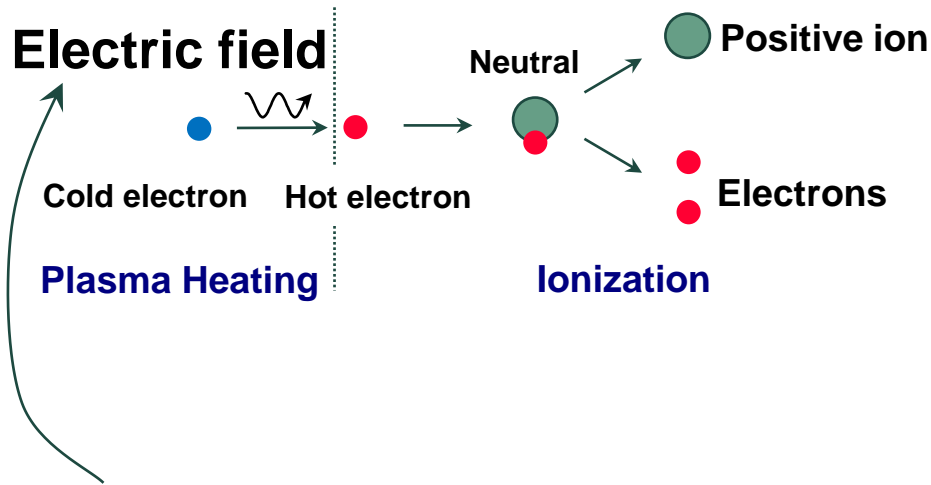

Type	Range
DC or low-frequency	$f < 1$ MHz
radio-frequency	$1 < f < 500$ MHz, commonly 13.56 MHz
microwave	$0.5 < f < 10$ GHz, commonly 2.45 GHz

## Developed Plasma Sources

### (1) DC Plasma Sources

- (A) Magnetron Discharges
- (B) PDP (Plasma Display Panel)

### (2) RF Plasma Sources

- (A) CCP (Capacitively Coupled Plasma)
- (B) ICP (Inductively Coupled Plasma, TCP)
- (C) Helicon wave
- (D) DFCCP
- (E) DFICP.....

### (3) $\mu$ -wave Plasma Sources

- (A) ECR (Electron Cyclotron Resonance)
- (B) Surface wave, ....

# RF (radio-frequency) discharge

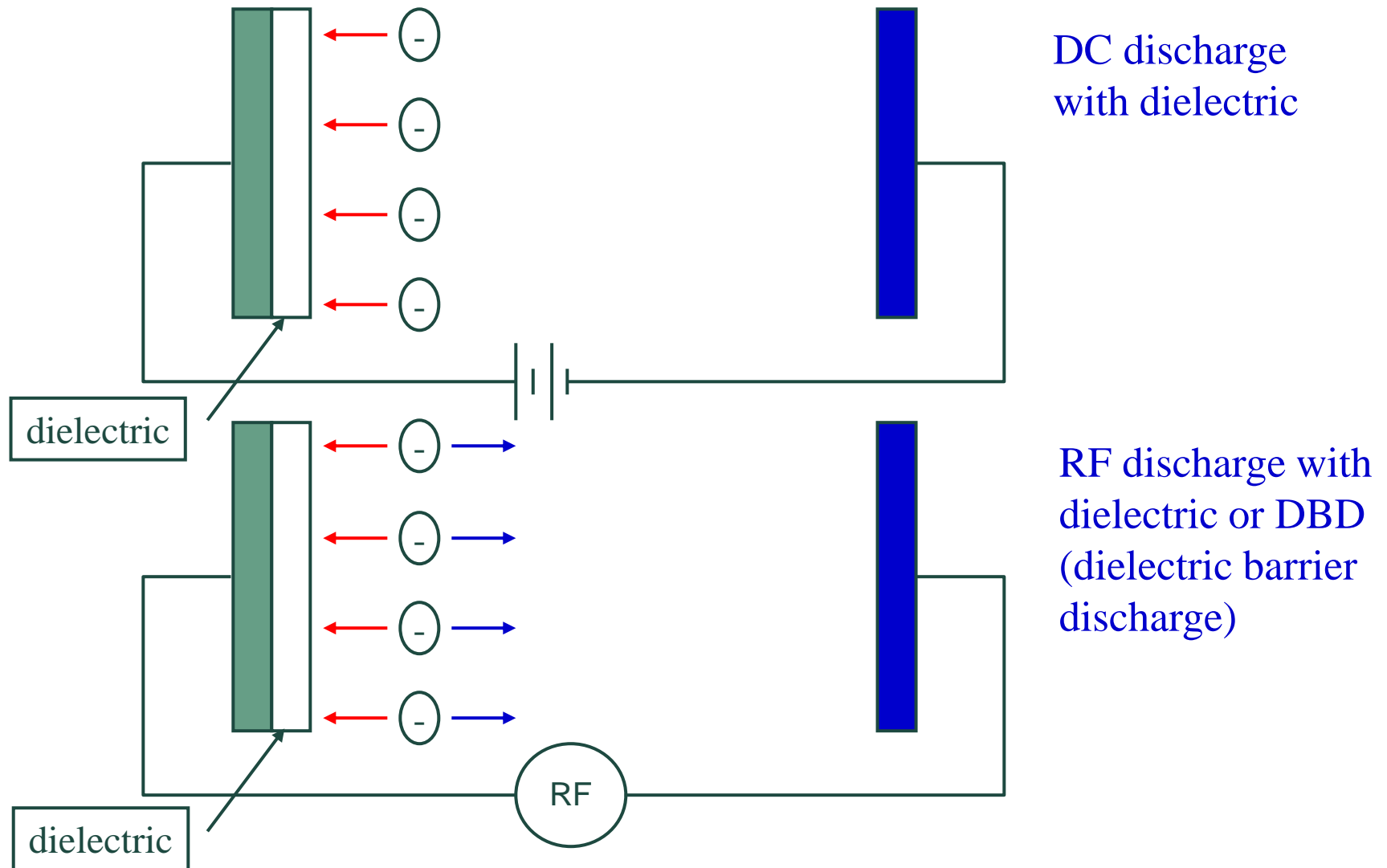

# Advantages of RF discharge

- Conductive or non-conductive electrodes can be used
  - self-discharge on insulating electrode
- Electrodes can be located either inside or outside of the plasma chamber
  - reduce contamination
- Higher ionization efficiencies than those of DC
- Sustained at lower gas pressures than DC
- Ion bombarding energy can be controlled by the negative self-bias
  - controllability of sheath potential

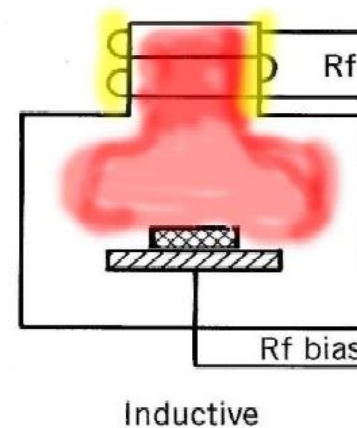
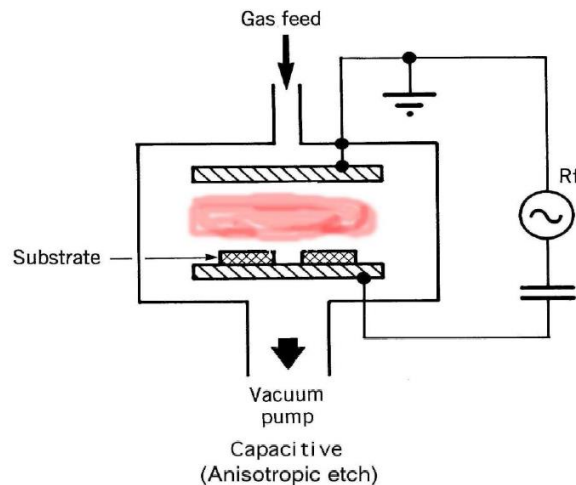

# RF discharges

- CCP (capacitively coupled plasma)

- Powered electrode is directly coupled to the plasma
- High electrostatic field is formed near the powered electrode
- Power transfer efficiency is relatively low but very uniform
- MF (~100 kHz), RF (13.56 MHz), VHF (>30 MHz), UHF (~100 MHz)

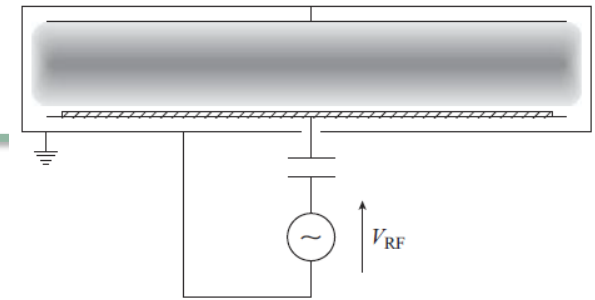

- ICP (inductively coupled plasma)

- Power is transferred to the plasma by the induction
- No electrode exists inside the plasma
- Power transfer efficiency is relatively high but local
- Substrate bias can be controlled independently

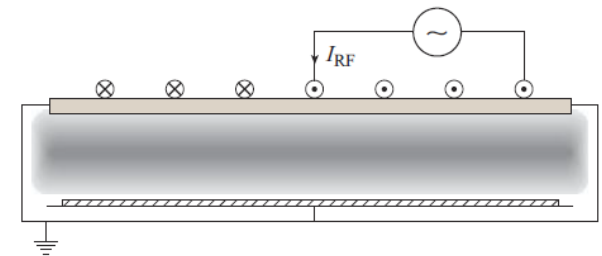

- Wave heated plasma

- Power is transferred from the propagating EM wave
- Power transfer efficiency is very high
- Microwave plasma and ECR, Helicon and helical plasma

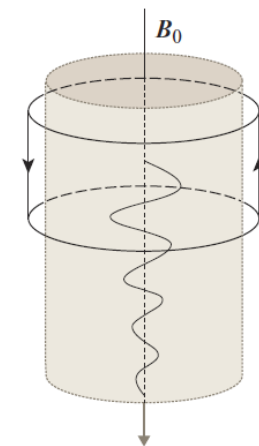



# CCP vs ICP

Magnetic induction: Faraday's law

$$\nabla \times \vec{E} = -\frac{\partial \vec{B}}{\partial t}$$

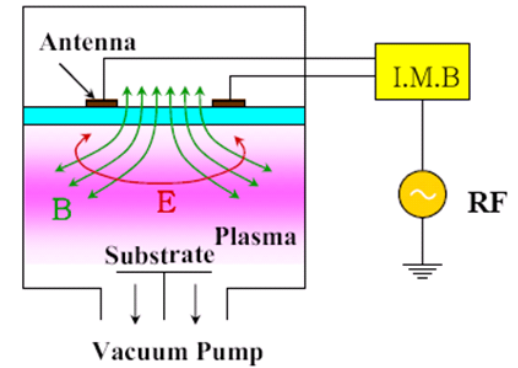
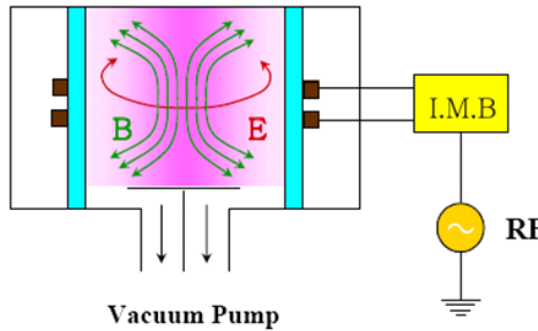
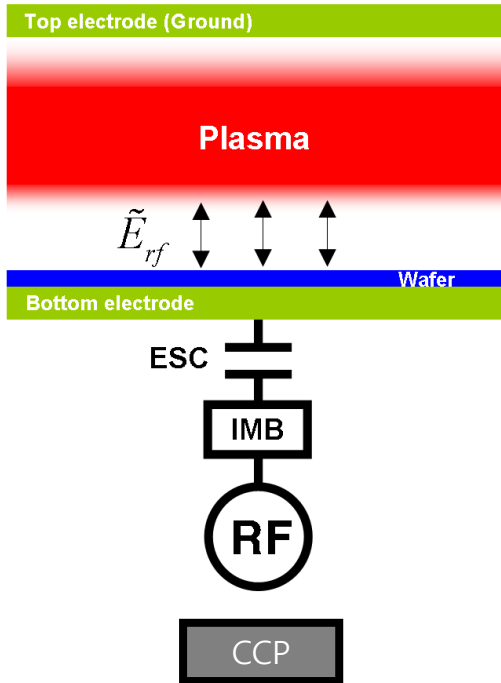

RF Coil current → Chamber 내부에 時變 자기장 생성  
 → Chamber 내부에 원주방향으로의 時變 E-field 형성 → 전자加速

# ECR (electron cyclotron resonance) source

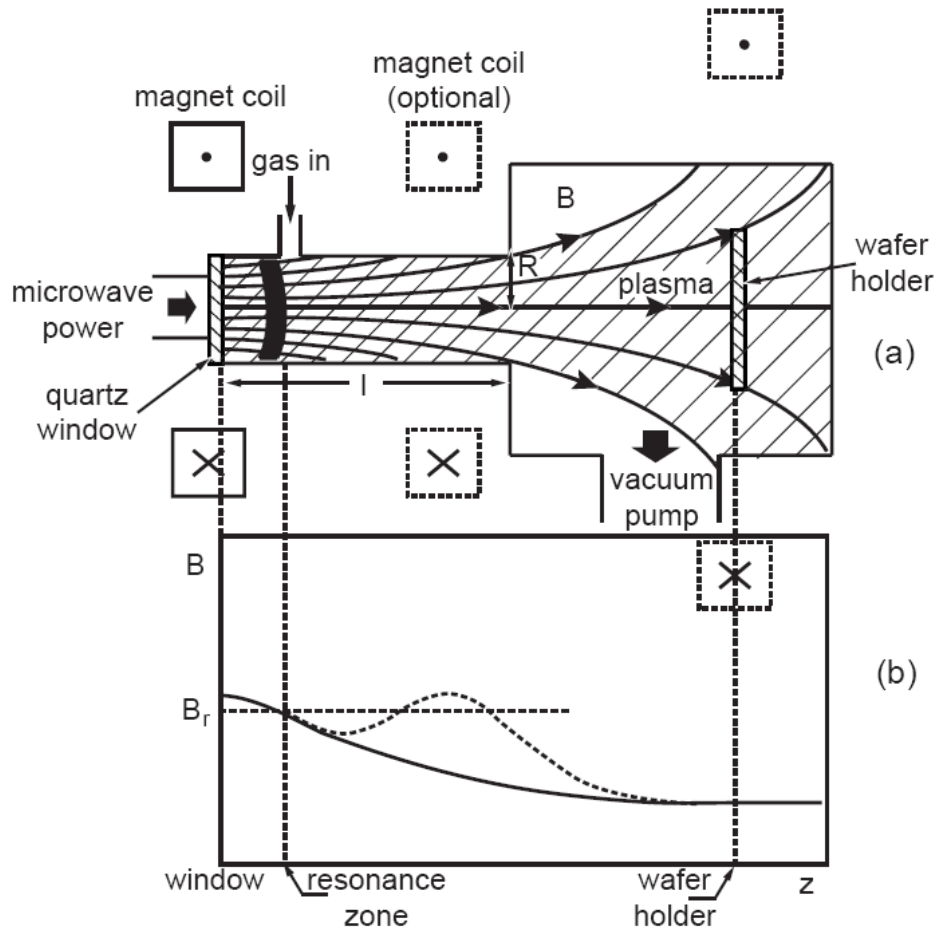

$$\omega_{MW} = 2\pi f_{MW} = \omega_{ce} = \frac{eB}{m}$$

